

Radial Winch 40.2 STBBB, STCCC

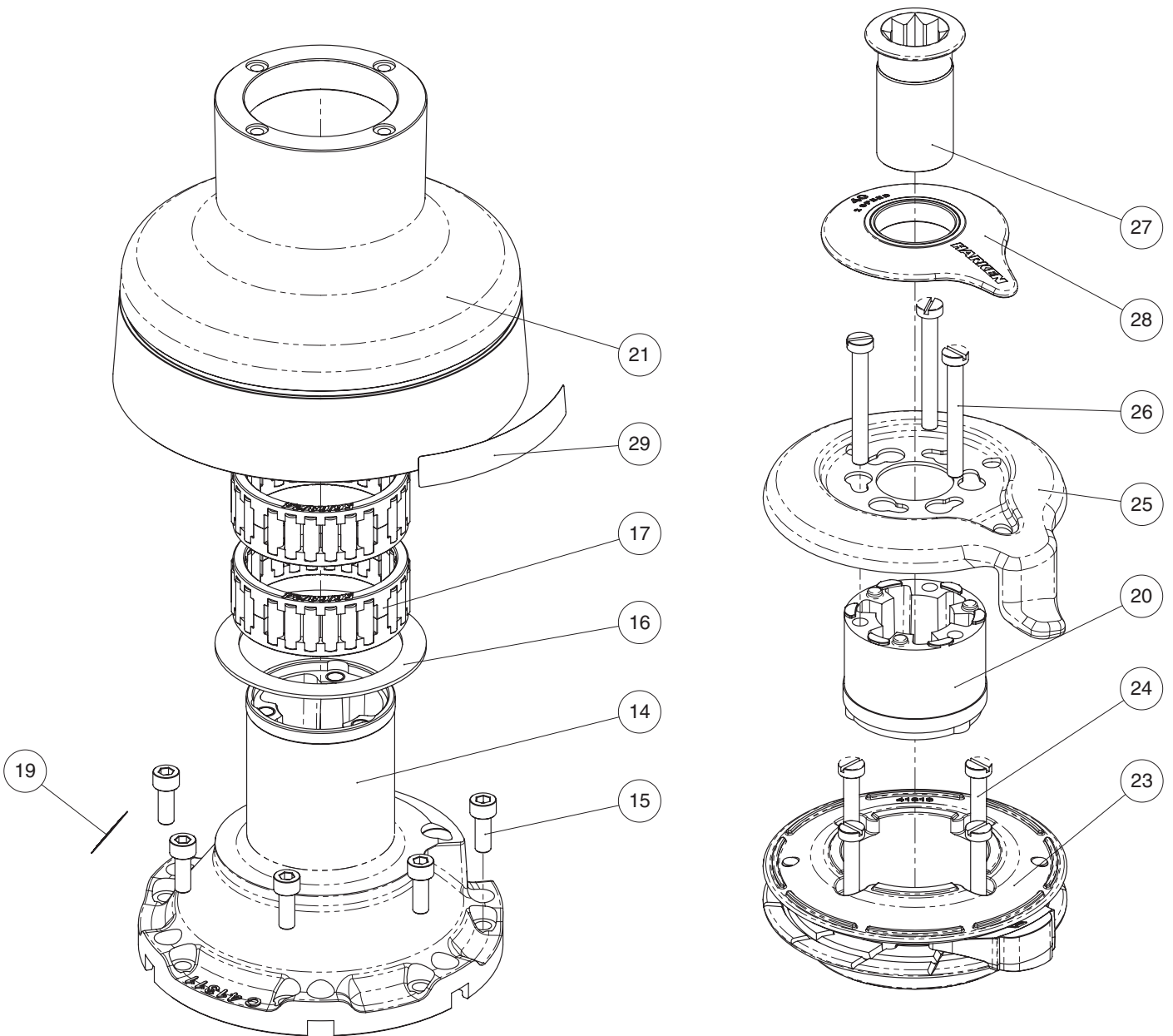
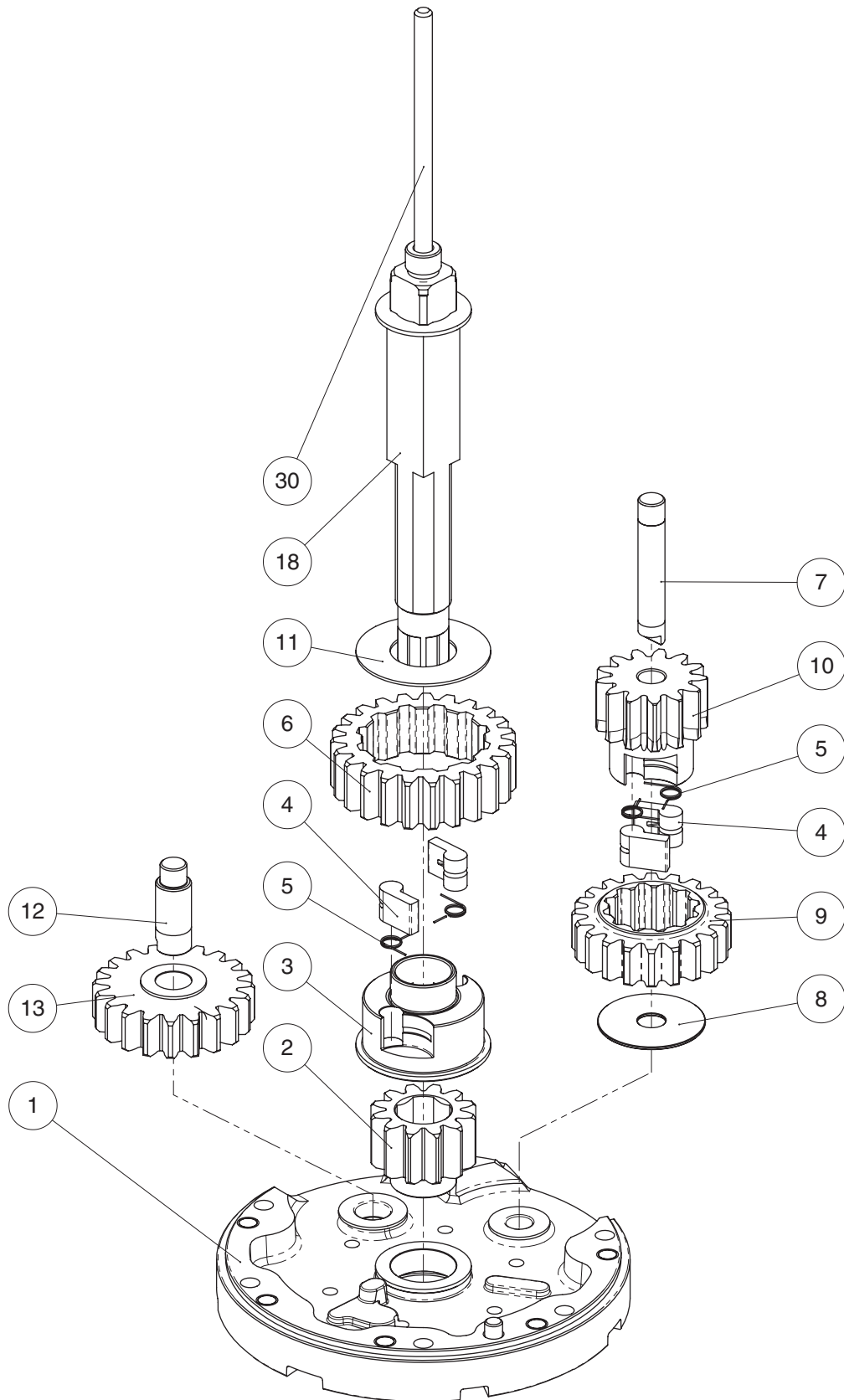

Radial Winch 40.2 STBBB, STCCC

Radial Winch 40.2 STCCC

CCC = All-Chrome bronze

Pos.	Q.ty	Code	Description	Pos.	Q.ty	Code	Description
1	1	A96633800	PERFORMA Assy Base Winch 40 EL/HY	16	1	S413150082	Washer Ø62xØ80x1.5
			<i>PERFORMA Base W40</i>	17	2	A74136000	Bearing Ø56xØ68x24
			<i>Heli-coil M6x9</i>	18	1	A94149800	Assy Central Shaft W40 EL/HY
	1	S413350080	<i>Roller Ø6x19</i>				<i>Central Shaft Pred. W40</i>
	1	S4130900A7	<i>Bushing Ø22xØ25x8.5</i>			1	S413880002
	1	S413960085	<i>Bushing Ø9xØ11x12</i>	19		Winch Serial Number Sticker	
	1	S413330085	<i>Bushing Ø12xØ14x11</i>	20	1	S4129400A0	Stripper arm support
2	1	S413020004	Gear Z12	21	1	S681050043	Drum CCC W40
3	1	S413030004	Pawls Carrier Ø8xN2	22	1	S281680097	Red line
4	4	S000080003	Pawl Ø8*	23	1	A96811900	Assy Jaws Winch 35/40 CCC
5	4	S000380001	Pawl Spring Ø8*				<i>Lower Jaw W35/40 CCC</i>
6	1	S412830041	Gear Z23				<i>Upper Jaw W35/40 RAL9003</i>
7	1	S413000004	Pin Ø9x55		1	S413610080W	<i>Peeler W20 - 40 RAL9003</i>
8	1	S279090002	Washer Ø36xØ9,5x1		4	S385970001	<i>SPRING</i>
9	1	S412970004	Gear Z20	24	4	M0601803	Screw UNI EN ISO 1207:1996 - M6x35 - A4
10	1	S412850041	Pinion Z13	25	1	S414200019	Stripper Arm W35/40
11	1	S413120002	Washer Ø22.5xØ45x1	26	3	M6007103	Screw M6x50 UNI6107
12	1	S413070004	Pin Ø9xØ12x32.5	27	1	A94149300	Assy Socket W35-80 EL/HY
13	1	A94130500	Assy Gear Z20				<i>Socket Handle W20/80</i>
	2	S414900080	<i>Gear Z20</i>		1	S414940085	<i>Washer Ø25xØ15x4</i>
			<i>Bushing Ø12xØ14x8</i>		1	S414930003	<i>Nut Screw for Disconnect Rod</i>
14	1	A94141500	Assy Housing Winch 40	1	M0679797	<i>O ring RC 2025 series</i>	
			<i>Support W40</i>	28	1	A76811200	Cover W40 CCC
	2	S414890080	<i>Heli-coil M6x9</i>	29		Winch Product Sticker**	
	1	S4130900A7	<i>Bushing Ø9xØ11x7</i>	30	1	S415060002	Disconnect Rod W40
	1	S4130900A7	<i>Bushing Ø22xØ25x8.5</i>				
15	6	M0635103	Socket head screw M6x16 UNI 5931				

*Available with service kit; see website www.harken.com

**Winch product sticker



Horizontal electric motor 12V/24V

TOP VIEW

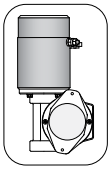

* **Motor installed in right-hand configuration.**

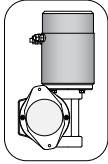

** **Motor installed in left-hand configuration.**

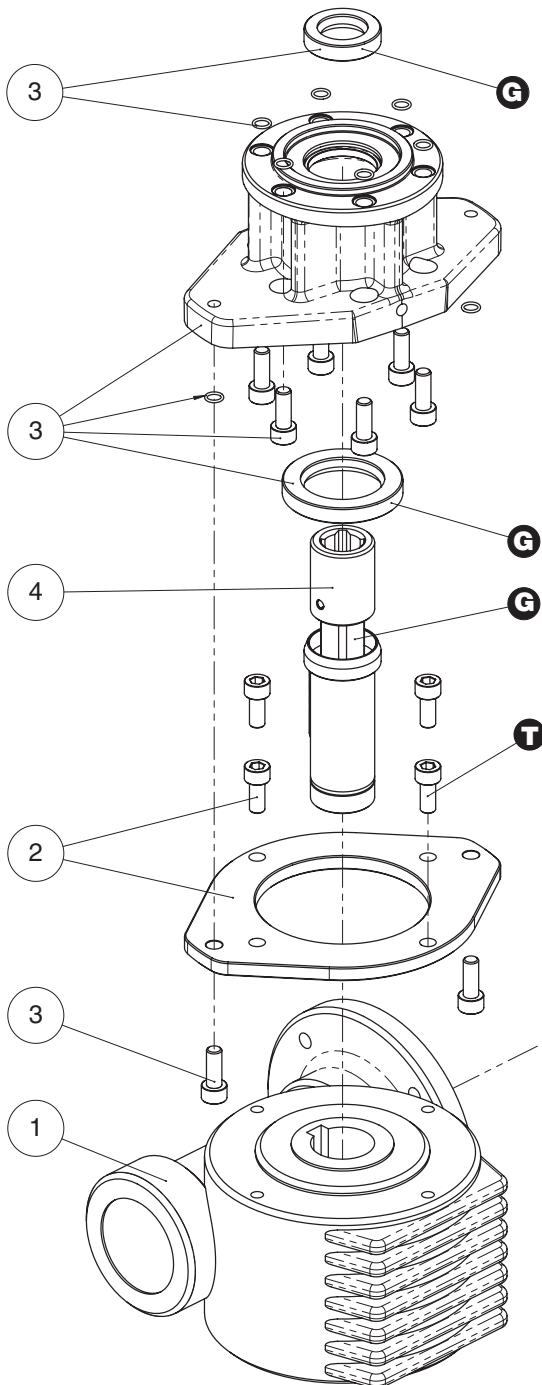

Pos.	Q.ty	Code	Description
1	1	A93127900	KIT Gear Reduction 1/24
	1	A94194900	KIT LM Gear Reduction 1/24
2	1	A94149200	KIT Assy Electric Motor Flange
	1	A94149200L	KIT Assy Electric Motor Flange Left
	4	M0606803	Electric Motor Flange Screw M6x14 UNI 5931
3	1	A94149500	KIT EL HO Motor Flange
	8	S415360003	Horizontal Motorgear Flange Screw M6x16 UNI EN ISO 5931:2003 precote coating
	8	M601560097	O-Ring Seal ORM 0055-10 (Ø5,5 x Ø1)
	1	M6007297	Lip seal Ø17xØ30x7
4	1	M0612097	Sealer Ø30xØ47x7
	1	A94161600	KIT EL HO Motor Clutch
			Shaft Motorgear HO
			Shaft GearMotor HO
			Hub GearMotor
	1	M0601402	Dowel UNI EN ISO 8752:2000- Ø4x24
	1	M6020097	O-ring 19.1x1.6
1	S418620001	Disconnect spring	
1	S414050080	Flange GearMotor Shaft HO	
1	M6010303	Key 8x5x40 UNI 7511	
5	1	A96015400	KIT EL Motor 12V 0,7kW
	1	A96015700	KIT EL Motor 24V 0,9kW
			Electric Motor
			Polarity motor sticker
			Screw stud M6x26
			Washer Ø6
			Nut M6 UNI5588
1	M6014206	Key DIN 6885 5x5x15	

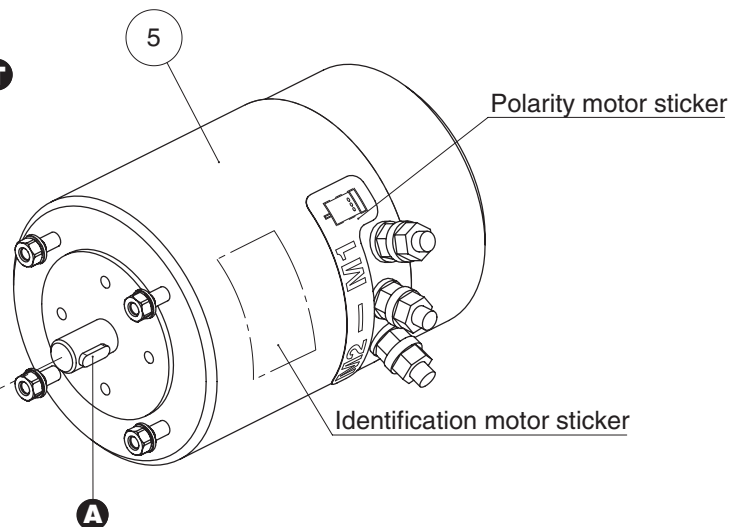

- A** **Anti-seize**
- G** **Harken® Grease**
- T** **Axial Threadlocker**