

Exploded view

Radial Winch 46.2 STA, STC, STCW

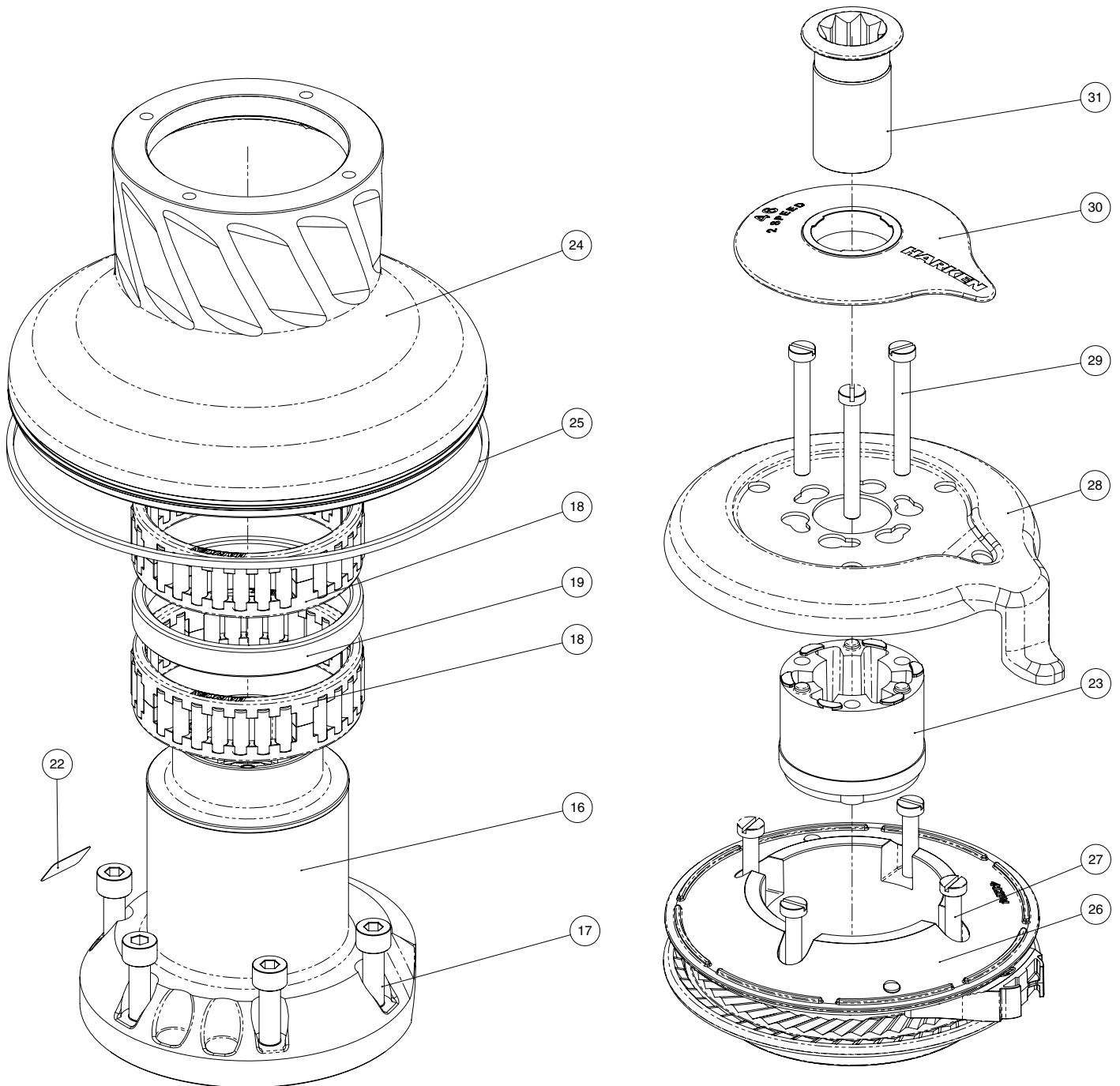
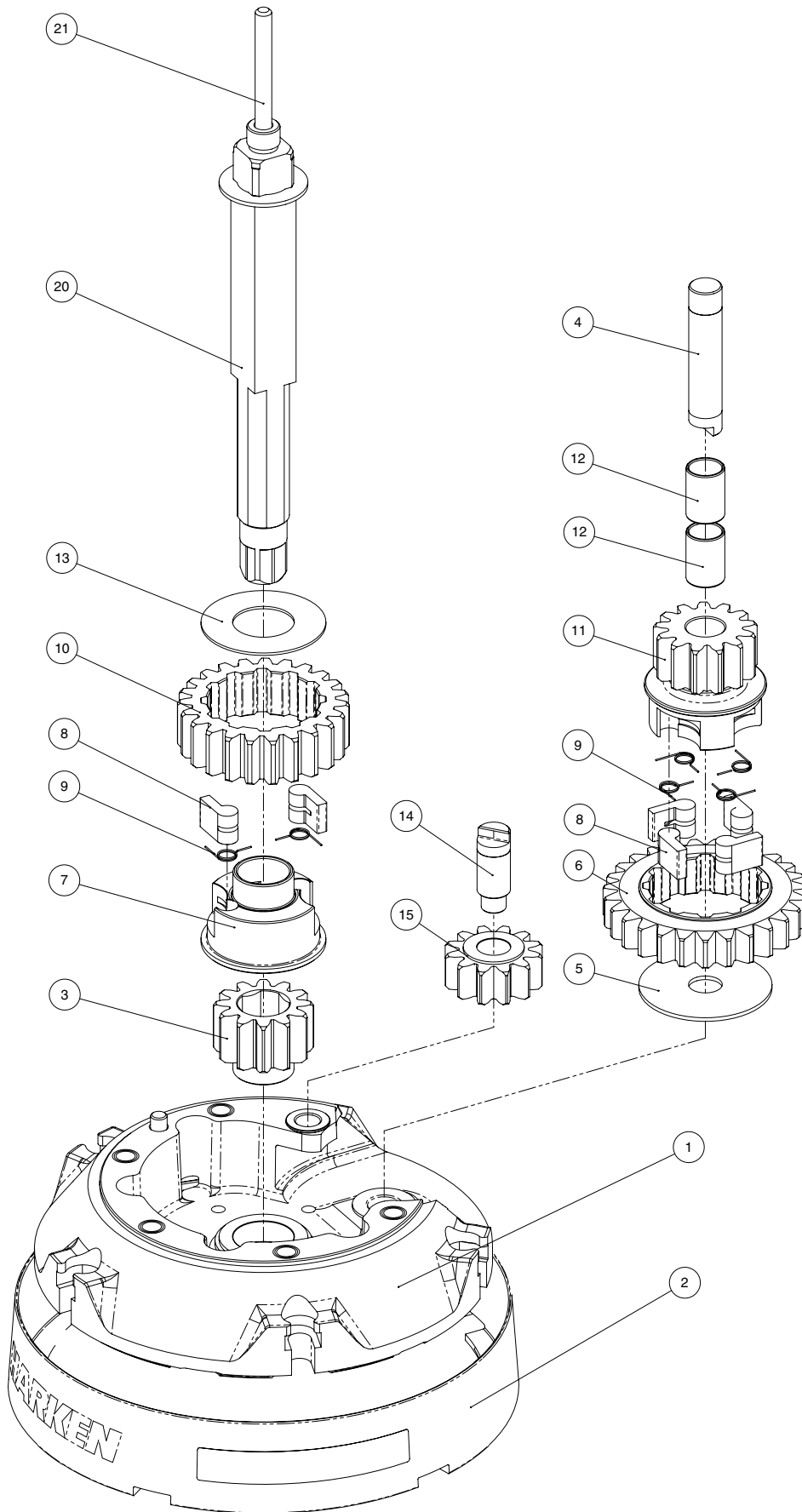

Radial Winch 46.2 STA, STC, STCW

Radial Winch 46.2 STC

C = drum in chrome bronze

Pos.	Q.ty	Code	Description	Pos.	Q.ty	Code	Description			
1	1	A94189700	Assy Base Winch 46 EL/HY Base W46 Heli-coil M8x10	18	2	A74133700	Bearing Ø75xØ87x26			
	1	S413350080	Roller Ø6x19	19	1	S413390080	Spacer			
	1	S4130900A7	Bushing Ø22xØ25x8.5	20	1	A94161000	Assy Central Shaft W46 EL/HY Central Shaft W46 EL/HY			
	1	S414890080	Bushing Ø9xØ11x7	1	1	S413880002	Washer Ø17.2xØ32x1.5			
	1	S413330085	Bushing Ø12xØ14x11	21	1	S416110002	Disconnect Rod W46			
2	1	A94132300	Assy Skirt Winch 46 Skirt W46 Winch Product Sticker**	22			Winch Serial Number Sticker			
				23	1	S4129400A0	Stripper arm support			
3	1	S413020004	Gear Z12	24	1	S413240043	Drum W46 C			
4	1	S413300004	Pin Ø12x60	25	1	S281690097	Red line			
5	1	S278170002	Washer Ø12.5xØ48x1.5	26	1	A94127300	Assy Jaws winch 46			
6	1	S413260004	Gear Z27				Lower Jaw W46			
7	1	S414260004	Pawls Carrier Ø8xN2				Upper Jaw W46			
8	6	S000080003	Pawl Ø8*				Peeler W46 - 50			
9	6	S000380001	Pawl Spring Ø8*	4	4	S385970001	SPRING			
10	1	S412830041	Gear Z23	27	4	M0601803	Screw UNI EN ISO 1207:1996 - M6x35 - A4			
11	1	S413250041	Pinion Z13	28	1	S413380019	Stripper Arm W46			
12	2	M6017694	IGUS Bushing PSM-1214-20	29	3	M6007103	Screw M6x50 UNI6107			
13	1	S413120002	Washer Ø22.5xØ45x1	30	1	S4127000A5	Cover 2 speed W46			
14	1	S413070004	Pin Ø9xØ12x32.5	31	1	A94149300	Assy Socket W35-80 EL/HY			
							Socket Handle W20/80			
15	1	A94133400	Assy Gear Z12 Gear Z12				1	1	S414940085	Washer Ø25xØ15x4
							2	1	S414900080	Bushing Ø12xØ14x8
16	1	A94132200	Assy Housing Winch 46 Housing Winch 46 Heli-coil M6x9	1	1	S414900080	Bushing Ø12xØ14x8			
				1	1	S413330085	Bushing Ø12xØ14x11			
				1	1	S4133200B3	Bushing for support			
				17	5	M0606303	Screw M8x25 UNI 5931			

*Available with service kit; see website www.harken.com

**Winch product sticker



Hydraulic motor

Pos.	Q.ty	Code	Description	Pos.	Q.ty	Code	Description
1	1	G045942000Y	Hydraulic motor W46-60	4	1	A94149100	KIT HY Motor Flange W46-70
2	1	S415000080	Hydraulic Motor Spacer	6	1	S415360003	Hydraulic Motorgear Flange Screw M6x16 UNI EN ISO 5931:2003 precote coating
3	1	A94193200	KIT Clutch HY Motor W46-70	6	1	M6015697	O-Ring Seal ORM 0055-10 (Ø5,5 x Ø1)
			Toothed coupling	6	1	M6007297	Lip seal Ø17xØ30x7
	1	M0620401	Connecting Coupling Ø31.5	1	1	M0621503	Washer D.13 U1751 DIN127
	1	S415010080	Spring pin 5x40 DIN1481	2	1	M0667103	Screw M12x35 UNI5931
	1	S326490001	Bushing				
	1	S329360082	Spring				
	1	M0635303	Washer				
	1		Screw M8x16 UNI6109				

