

Installation and Maintenance Manual

MRPW-02

Powered Performa™ Winch **46.2 STP E/HY**



HARKEN®

Introduction	3
Technical characteristics	3
<i>Performance data</i>	3
<i>Weight</i>	4
<i>Maximum working load</i>	4
Outline	4
<i>Winch 40-2 STP E</i>	4
<i>Horizontal electric motor</i>	4
<i>Vertical electric motor</i>	5
<i>Hydraulic motor</i>	5
Installation	6
<i>Installation procedure</i>	7
<i>Winch installation procedure</i>	8
<i>Positioning the self-tailing arm</i>	9
<i>Motor installation procedure</i>	9
<i>Electric wiring diagrams</i>	10
<i>Hydraulic connections diagram</i>	13
Maintenance	14
<i>Washing</i>	14
<i>Maintenance table</i>	14
<i>Winch disassembly procedure</i>	14
<i>Winch exploded view with maintenance products</i>	18
<i>Winch assembly</i>	19
Harken® limited worldwide warranty	20
Ordering spare parts	20
Exploded view	21
<i>Performa Winch 40.2 STP E/HY</i>	21
<i>Horizontal electric motor</i>	24
<i>Vertical electric motor</i>	25
<i>Hydraulic motor</i>	26
Parts list	22
<i>Performa Winch 40.2 STP E/HY</i>	22
<i>Horizontal electric motor</i>	24
<i>Vertical electric motor</i>	25
<i>Hydraulic motor</i>	26

Introduction

This manual gives technical information on winch installation and maintenance, including disassembling and reassembling.

This information is DESTINED EXCLUSIVELY for specialised personnel or expert users.

Installation, disassembling and reassembling of the winch by personnel who are not experts may cause serious damage to users and those in the vicinity of the winch.

Harken® accepts no responsibility for defective installation or reassembly of its winches.

In case of doubt the Harken® Tech Service is at your disposal at techservice@harken.it

This Manual is available only in English. If you do not fully understand the English language, do not carry out the operations described in this Manual.

Technical characteristics

	Power ratio	Gear ratio
1st speed	11,70 : 1	2,30 : 1
2nd speed	46,50 : 1	9,17 : 1

The theoretical power ratio does not take friction into account.

Performance data

Winch 46.2 STP E
(electric)

	horizontal motor				vertical motor			
	12 V (700 W)		24 V (900 W)		12 V (1500 W)		24 V (2000 W)	
	1st speed	2nd speed	1st speed	2nd speed	1st speed	2nd speed	1st speed	2nd speed
line speed (m/min)**	26,7	6,7	33,5	8,4	35,1	8,8	42,3	10,7
max load (Kg)	315	1300	315	1300	315	1300	315	1300

**Line speed is measured with no load

winch 46.2 STP E		motor nominal power (W)		current absorption at winch MWL (A)	
		12 V	24 V	12 V	24 V
		horizontal	vertical	horizontal	vertical
	horizontal	700	900	220	170 (A)
	vertical	1500	2000	220	120

Winch 46.2 STP HY
(hydraulic)

	1st speed	2nd speed
line speed (m/min)*	52,5	13,2
max load (Kg)***	315	1300

* at 20 L/min oil flow (5,28 Gal/min)

*** at 120 bar a 20 L/min

NOTE

The ratio the line load - pressure are evaluated at flow 20 l/min,

at different flow the line load - pressure ratio change and it's minimum at motor stall.

The pressure on the graph it's the pressure drop between in and out motor ports.

The performance are evaluated measuring the pressure and flow on the motor ports.

Performance data based on oli with a viscosity of 35mm²/s [165 SUS] and temperature of 50° [120° F]

Weight

	ST EH	ST EV	ST H
weight (Kg)	14,9	16,7	12,7

Versions:

EH = horizontal electric winch

EV = vertical electric winch

H = vertical hydraulic winch

Maximum working load

WARNING!



The maximum working load (MWL) for the 46.2 ST E/HY Performa™ Winch is 1300 Kg (2866 lb). Subjecting the winch to loads above the maximum working load can cause the winch to fail or pull off the deck suddenly and unexpectedly during high loads causing severe injury or death.

Outline

Winch 46.2 STP E/HY

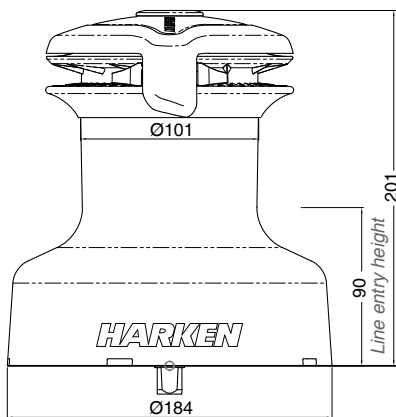

Horizontal electric motor (12 V / 24 V)

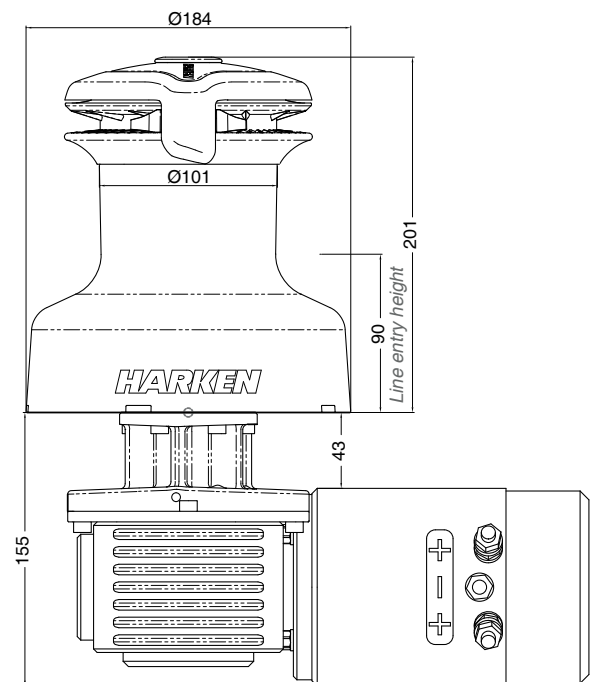

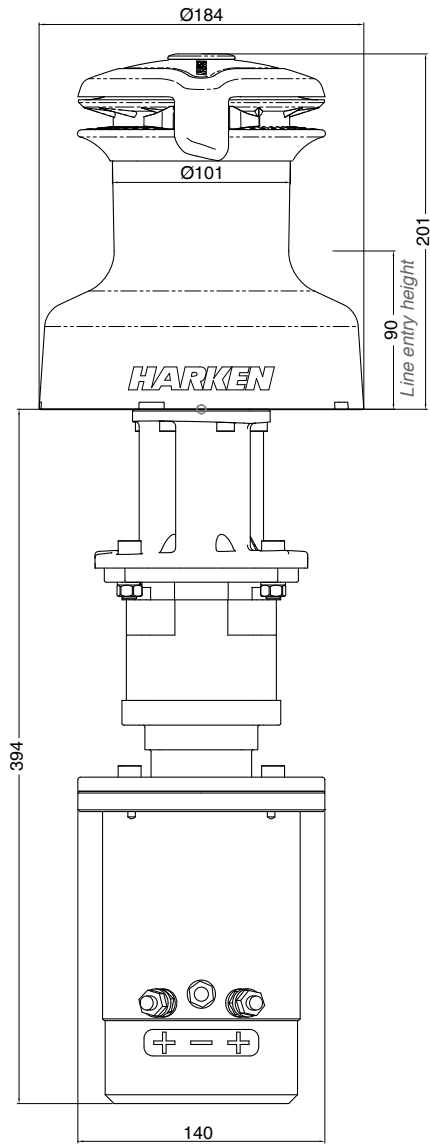
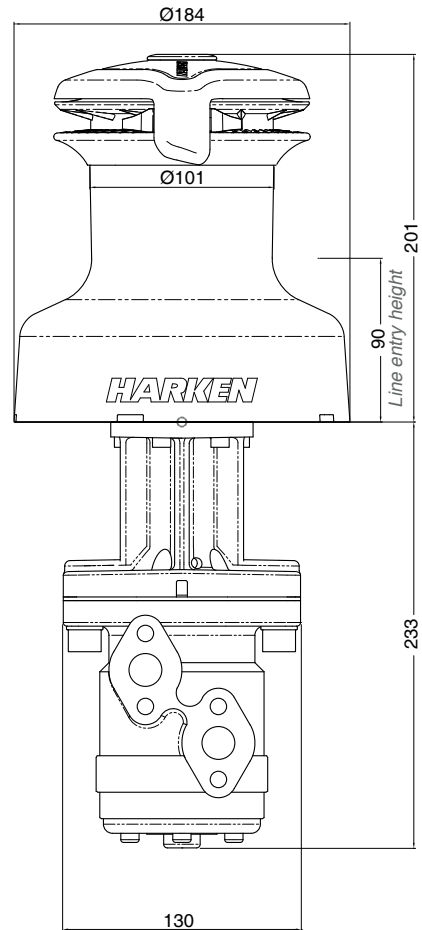
Vertical electric motor (12 V / 24 V)Hydraulic motor

Installation

The winch must be installed on a flat area of the deck, reinforced if necessary to bear a load equal to at least twice the maximum working load of the winch.

It is the installer's responsibility to carry out all structural tests needed to ensure that the deck can bear the load.

Harken® does not supply the screws needed to install the winch since these may vary depending on the deck on which it is to be installed.

It is the installer's responsibility to choose the correct screws taking account of the loads they will have to bear.

Harken® assumes no responsibility for incorrect installation of its winches or for an incorrect choice of mounting screws.

DANGER!

Incorrect installation of the winch may cause severe injury or death. Consult the yard that built the boat in the case of doubt over the correct positioning of the winch.



WARNING!

Failure to use the correct number and type of mounting fasteners or failure to ensure the correct deck strength can result in the winch pulling off the deck suddenly and unexpectedly during high loads causing severe injury or death.



WARNING!

Verify the entry angle of the sheet. This must be 8° with tolerance of $\pm 2^\circ$, to avoid sheet overrides and damaging the winch or making the winch inoperable leading to loss of control of the boat which can lead to severe injury or death.

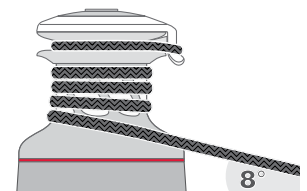

WARNING!

Mount the winch on the deck so that the drive gear is positioned where the sheet enters the winch drum. Incorrect position of drive gear can weaken winch leading to failure which can cause an accident leading to severe injury or death.

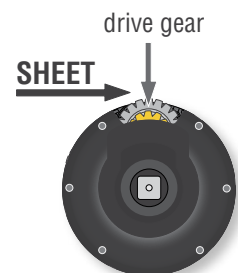

After correctly positioning the final pinion with respect to the load, check that the motor, gearing, electrical wiring and/or hydraulic pipes can be housed below decks. To help find the optimal compromise, remember that, to make the installation of the motor easier, it can be coupled to the winch in any one of four different positions that differ by 60° from each other.

Once you have decided the correct mounting position for the winch on the deck and checked the space available below deck, proceed with the installation.

Procedure

To install the winch you must remove the drum and use Socket Head (SH) bolts.

Tools needed

 One medium flat-bladed screwdriver

To identify the various parts, refer to the exploded view at the end of this Manual.

 Torque to apply when assembling



1. Pull out the disconnect rod n°30



2. Unscrew the central screw (\approx 2Nm/18 in-lb)



3. Slide off the assy socket n°27 and the cover n°26.
Pay attention to the o-ring in the socket.



4. Unscrew the three screws n°25
(\approx 4Nm/35 in-lb)



5. Remove the stripper arm n°24 by
rotating and lifting it.



6. Lift off the drum n°28

Install the winch on the deck in the position you have chosen, keeping in mind the limits described on page 4 and using socket head (SH) bolts. (See paragraph on installation)

Winch installation procedure

Carry out the **Procedure**, then install the winch on the deck in the chosen position.

NOTICE

Before drilling the deck, check the space available below deck for the flange and the motor

- A.** Position the base of the winch on the deck and mark the position of the holes or use the drilling cut-out template at the point where you have decided to place the winch.

Below is a reduced scale diagram.

The drilling cut out template is available on the Harken® website, www.harken.com

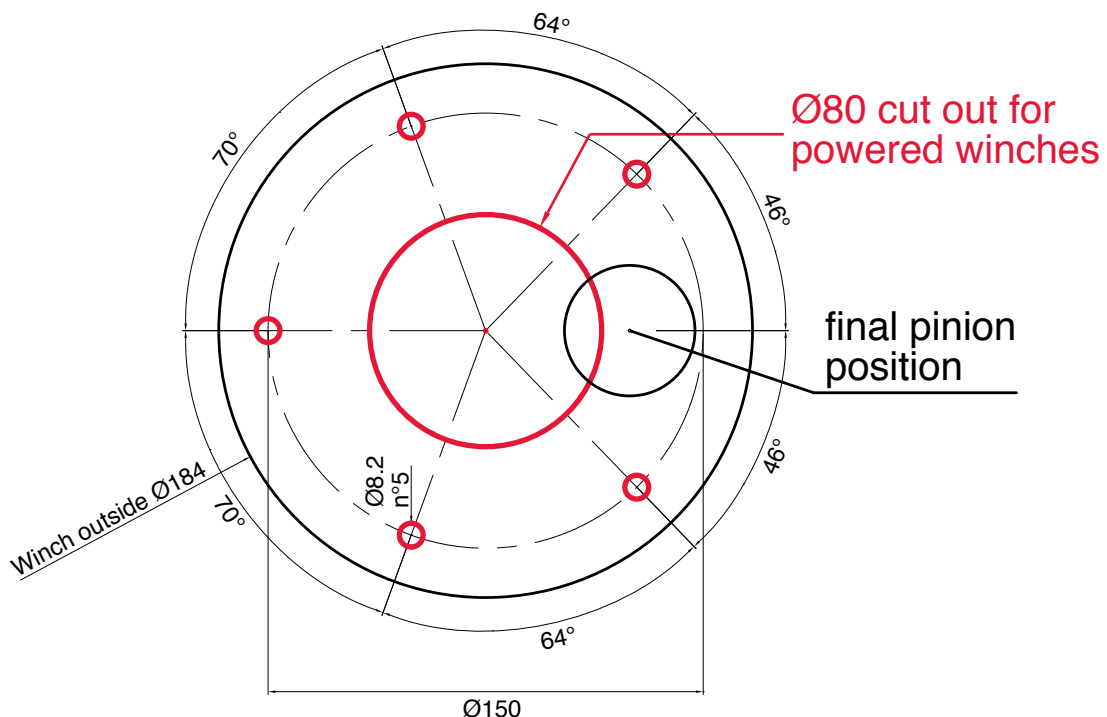

- B.** Remove the winch and drill the five 8.2 mm diameter holes.
- C.** Bolt the base of the winch to the deck using five M6 Socket Head (SH) bolts (no supplied by Harken®), correctly chosen for the thickness and type of the boat deck. Consult the yard that built the boat in case of doubt.



WARNING!

To install the winch on the deck, use only bolts in A4 stainless steel (DIN 267 part11). Bolts made of other materials may not have sufficient strength or may corrode which can result in winch pulling off deck suddenly and unexpectedly during high loads causing severe injury or death.

NOTICE

To mount winches on the deck, do not use countersunk bolts.

- D.** Fill the mounting holes with a suitable marine sealant.
- E.** Remove the excess adhesive/sealant from the holes and base drainage channels

F. Reassemble the winch following the steps of the **Procedure** in the reverse order, and apply the products indicated in the section on maintenance.

NOTICE

Before closing the winch, make sure the holes and drainage channels in the base of the winch are not obstructed.





Positioning the self-tailing arm

Position the self-tailing arm so that the line leaving the winch is led into the cockpit.

Motor installation procedure

Once you have installed the winch on the deck, proceed with motor installation. The motor can be coupled to the winch in different positions. Check the space available below deck and choose the suitable position.

Tools needed

-  A number five hex key
-  A number six hex key (only for vertical electric motor)
-  A number ten hex key (only for hydraulic motor)
-  Two number thirteen wrenches



1. Position the flange (see Page 10)



2. Tighten the six screws (≈ 8 Nm/ 71 in-lb)



3. Position the reduction gear and motor



4. Tighten the two screws (≈ 8 Nm/ 71 in-lb).
Be sure to align the flange.

NOTICE

Before positioning the flange, check to make sure that seal is seated correctly.



After winch is assembled and before sailing, test the powered winch functioning: insert the lock-in winch handle in the handle socket and check that the disconnect rod must disconnect gearbox.

Electric wiring diagrams

To guarantee greater efficiency in terms of safety and long life, for certain winch models it is obligatory to install the WLC 200R.



WARNING! Consult the table below to check for which winch models it is obligatory to install the WLC200R and for which it is recommended.

WINCH PERFORMA™	Horizontal motor		Vertical motor	
	12 V	24 V	12 V	24 V
46.2	recommended	recommended	obligatory	obligatory

For more information, refer to the WLC200R Manual.

Refer to the following diagrams for the electric wiring:

Horizontal 12 V / 24 V motor installed without WLC200R

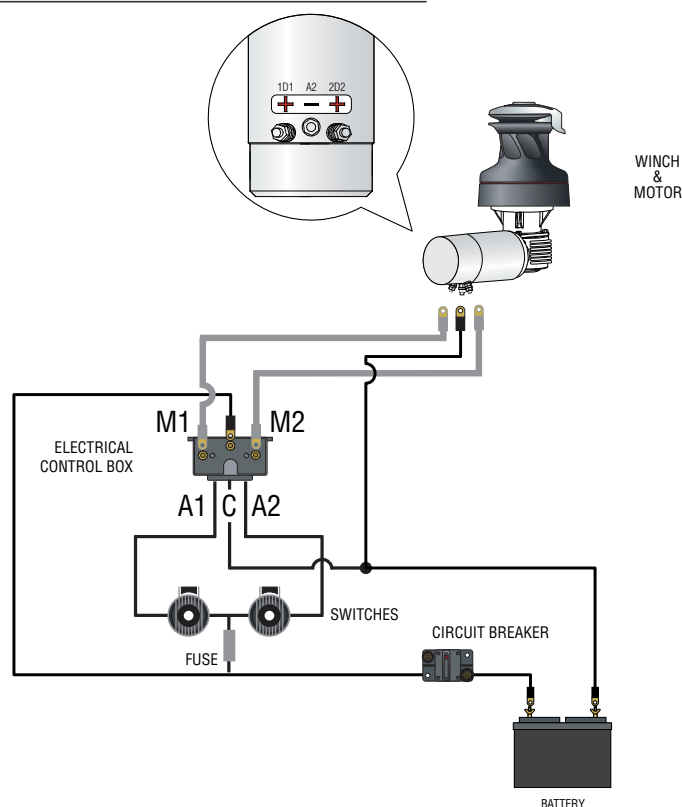

Horizontal 12 V / 24 V motor in right-hand configuration installed with WLC200R

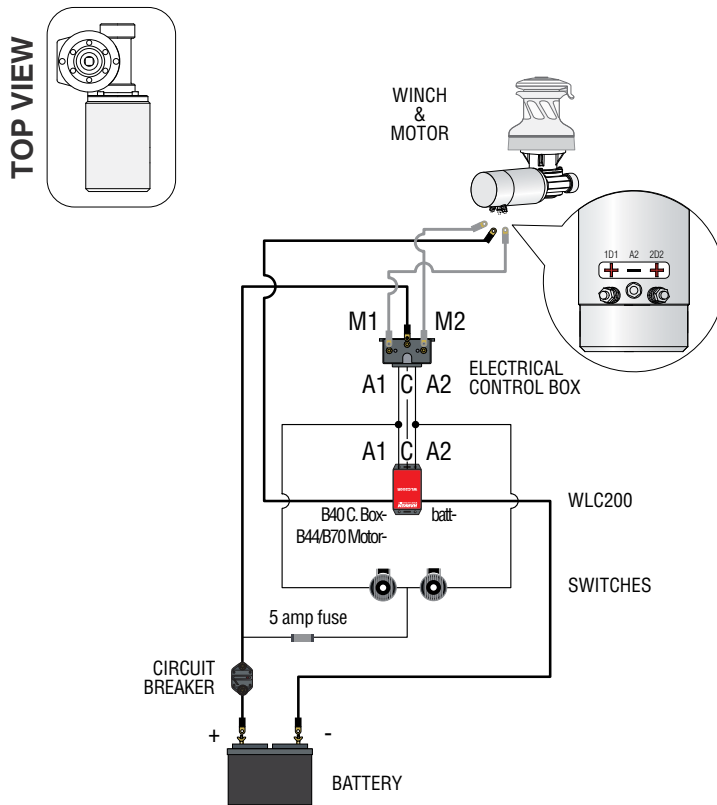

Horizontal 12 V / 24 V motor in left-hand configuration installed with WLC200R

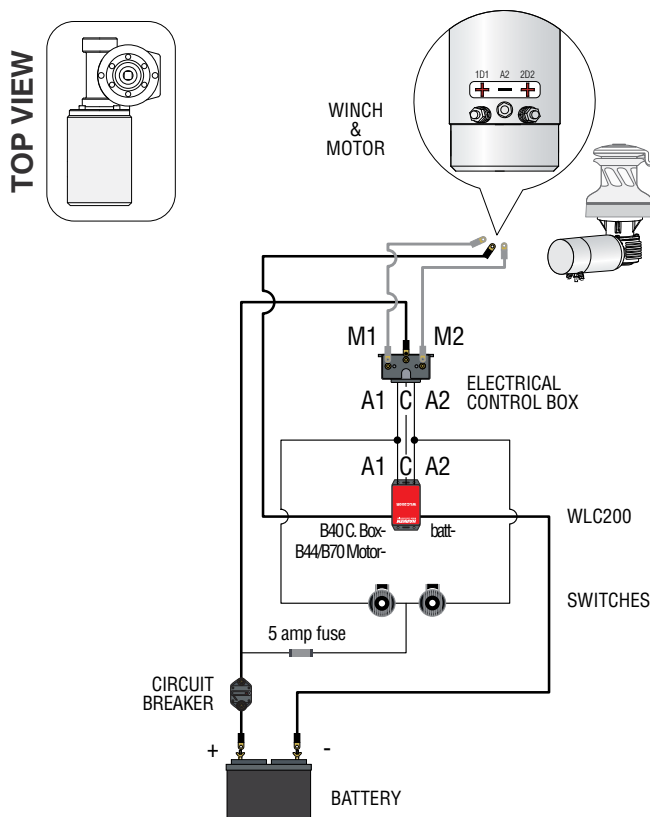

Vertical 12 V / 24 V motor with WLC200R

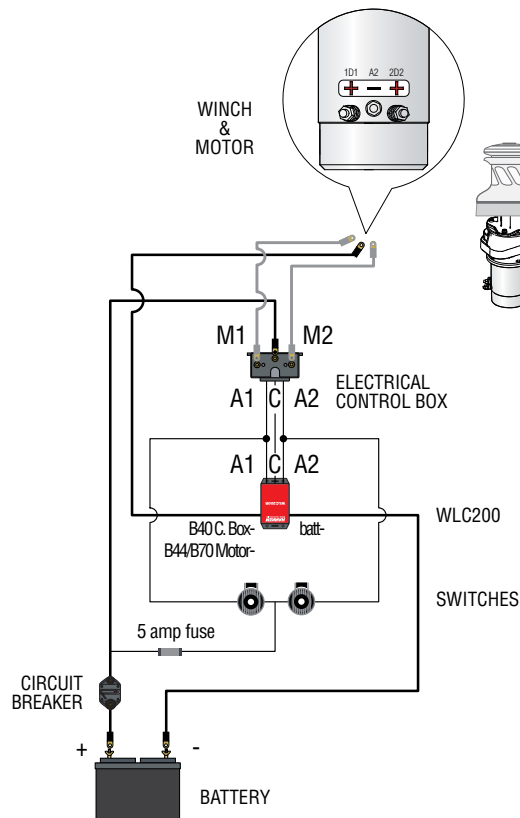

Fasten electric control box containing solenoids to bulkhead or wall. Install remote circuit breaker between power supply and electric control box. Locate push-buttons on deck in a convenient spot for easy winch operation.

Refer to the following chart for wire size:

Total distance between winch and battery

Winch size	Current voltage	Under 16.4 ft AWG	Under 5 m mm ²	16.4 - 32.8 ft AWG	5 m - 10 m mm ²	32.8 - 49.2 ft AWG	10 m - 15 m mm ²	49.2 - 65.6 ft AGW	15 m - 20 m mm ²
46.2	12 V	2	32	0	50	00	70	000	95
46.2	24 V	5	16	3	25	2	35	0	50

NOTICE

To connect motor, attach cable terminals to clamps between nut and lock nut. Hold nut in contact with motor using a spanner and tighten other nut with second spanner. Take special care not to turn the central spindles. Be careful not to turn central spindles. These instructions apply when assembling and disassembling. We recommend using a torque wrench so as to obtain a torque equal to and no greater than 10 Nm (88 in-lb).

**NOTICE**

Note that correct electrical contact sequence is:
Nut – Cable Terminal – Self-Locking Washer – Lock Nut

Hydraulic connections diagram

The hydraulic motor must to be connected to a hydraulic system using two high-pressure tubes which serve for input or output according to the direction in which the motor will be run. The motor also needs a third connection with a low pressure tube for drainage, so that excess oil can return to the main tank to avoid shortening the life of the motor. This motor uses an open centre valve.

Refer to the following chart for the hydraulic system:

For the hydraulic motor:

Input/output pipe thread: G 1/2 – depth 15 mm

Drainage pipe thread: G 1/4 – depth 12 mm

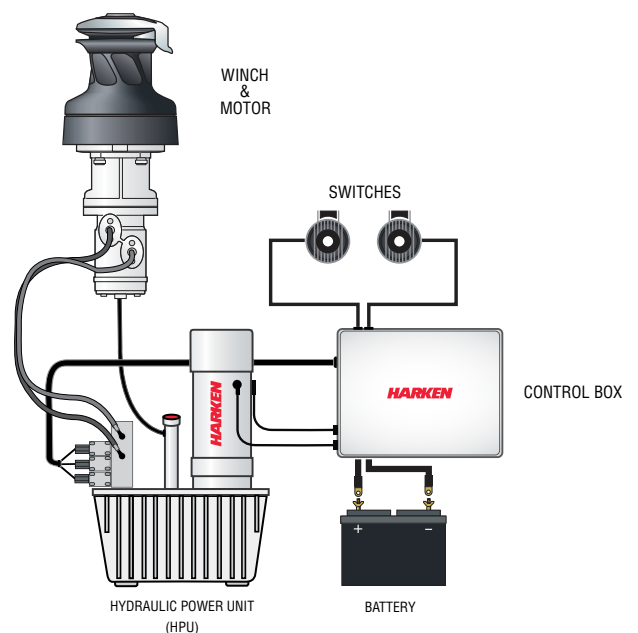

Maintenance

Washing

Winches must be washed frequently with fresh water, and in any case after each use.

Do not allow teak cleaning products or other cleaners containing caustic solutions to come into contact with winches and especially anodised, chrome plated or plastic parts.

Do not use solvents, polishes or abrasive pastes on the logos, on the stickers on the winches or on any anodized, chrome plated and plastic surfaces.

Make sure that the holes and drainage channels in the base of the winch are not obstructed so that water does not collect.

Maintenance table

Winches must be visually inspected at the beginning and end of every season of sailing or racing. In addition they must be completely overhauled, cleaned and lubricated at least every 12 months. After an inspection, replace worn or damaged components. Do not replace or modify any part of the winch with a part that is not original.

**WARNING!**

Periodic maintenance must be carried out regularly. Lack of adequate maintenance shortens the life of the winch, can cause serious injury and also invalidate the winch warranty. Installation and maintenance of winches must be carried out exclusively by specialized personnel.

In the case of doubt contact Harken® Tech Service at techservice@harken.it

**WARNING!**

Make sure that the power is switched off before installing or carrying out maintenance on the winch.

Winch disassembly procedure

Tools needed

 One medium flat-bladed screwdriver

 A number five hex key

 Brush

Rags

To identify the various parts refer to the exploded view at the end of this Manual.

 Torque to be applied in assembly phase

Carry out procedure as shown in the paragraph on winch installation and then do the following:



7. Completely unscrew the three screws n° 25 and remove the stripper arm support n°21



8. Slide out the central shaft n°19



9. Unscrew the 5 hex screws n°16
( 20Nm/177 in-lb)



10. Remove the assy housing n°15
Important: washer n°12 may remain inside the drum support!



11. Remove the gear n°14



12. Remove the washer n°12



13. Remove the gearing n°9 and remove the pawls n°7. To facilitate the operation press the spring against the pawl with a blade.

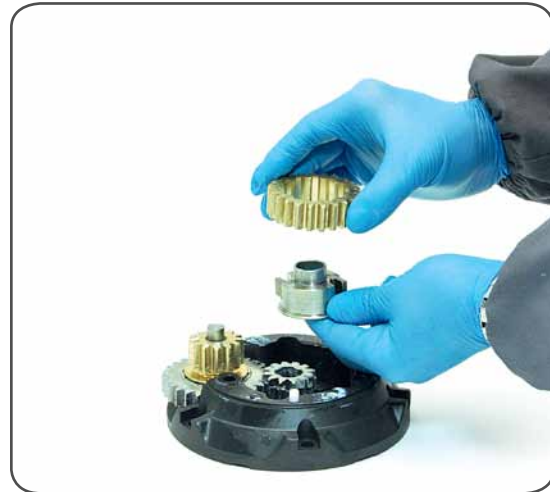

14. Slide off gear n°2



15. Remove the pinion n°10.



16. Slide off gear n°5



17. Remove the washer n°4.

If it is necessary to replace any **jaws** of the winch, proceed as follows:



I. Unscrew the 4 screws n°23
($\approx 4\text{Nm}/35\text{ in-lb}$)



II. Remove the jaws n°22

Inspect balls inside the drum and carefully check the correct position; if it is necessary to put back any balls, push balls in the race (as shown below):



Once the winch is completely disassembled, clean the parts: use a basin of diesel oil to soak metal components and rinse plastic parts in fresh water. Once you have done this, dry the parts with cloths that do not leave residue.

Inspect gears, bearings, pins and pawls for any signs of wear or corrosion.

Carefully check the teeth of gears and ring gears to make sure there are no traces of wear.

Check the roller bearings and check there are no breaks in the bearing cages.
Replace worn or damaged components.

Carry out maintenance on components using the products listed below.
For more information on which products to use where, refer to the exploded diagram below.

Use a brush to lightly lubricate all gears, gear pins, teeth and all moving parts with grease.
Lightly lubricate the pawls and springs with oil. Do not use grease on the pawls!

Winch assembly

Make sure that the holes and drainage channels in the base of the winch are not obstructed. Assemble the winch in the reverse order of the sequence in the section on disassembly.

To tighten bolts, use the torque indicated in the disassembly procedure.



If the jaws have been disassembled, insert peeler between the two jaws, taking care that the letters TOP on the peeler are facing upwards.

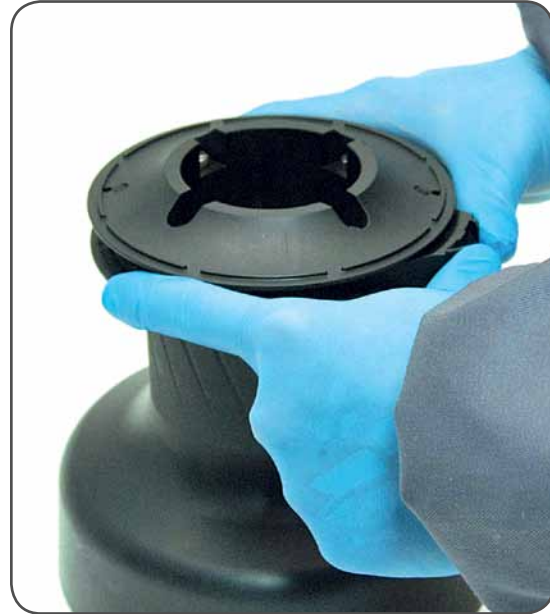

When positioning the stripper arm, align the peeler with it.

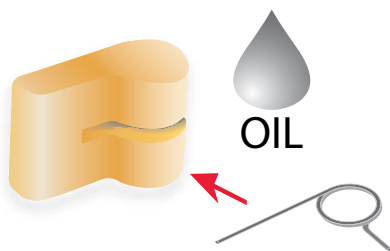

To assemble the pawls:

correctly position the spring in its housing as shown at left. Hold the spring closed and slide the pawl into its housing. Once in position, check that the pawls can be easily opened and closed with a finger.

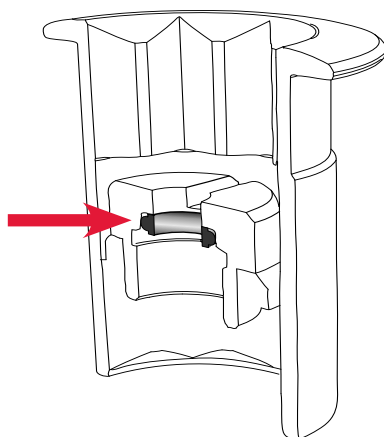

NOTICE

Before screw the central screw, check the correct position of the o-ring in the assy socket.

In case of doubt concerning the assembly procedure contact Harken® Tech Service: techservice@harken.it

Harken® limited worldwide warranty

Refer to the Harken® Limited Worldwide Warranty in the Harken® Catalogue and on the website www.harken.com

Ordering spare parts

Spare parts can be requested from Harken® as described in the Harken® Limited Worldwide Warranty, indicating the part number in the Parts List and including the serial number of the winch for which the parts are required.

The serial number of the winch is printed on a plate on the drum support of the winch.



Manufacturer

Harken® Italy S.p.A.

Via Marco Biagi, 14
22070 Limido Comasco (CO) Italy
Tel: (+39) 031.3523511
Fax: (+39) 031.3520031
Email: info@harken.it
Web: www.harken.com

- **Tech Service**
Email: techservice@harken.it
- **Customer Service**
Tel: (+39) 031.3523511
Email: info@harken.it

Headquarters

Harken®, Inc.

1251 East Wisconsin Avenue
Pewaukee, Wisconsin 53072-3755 USA
Tel: (262) 691.3320
Fax: (262) 691.3008
Email: harken@harken.com
Web: www.harken.com

- **Tech Service**
Email: technicalservice@harken.com
- **Customer Service**
Tel: (262) 691-3320
Email: customerservice@harken.com

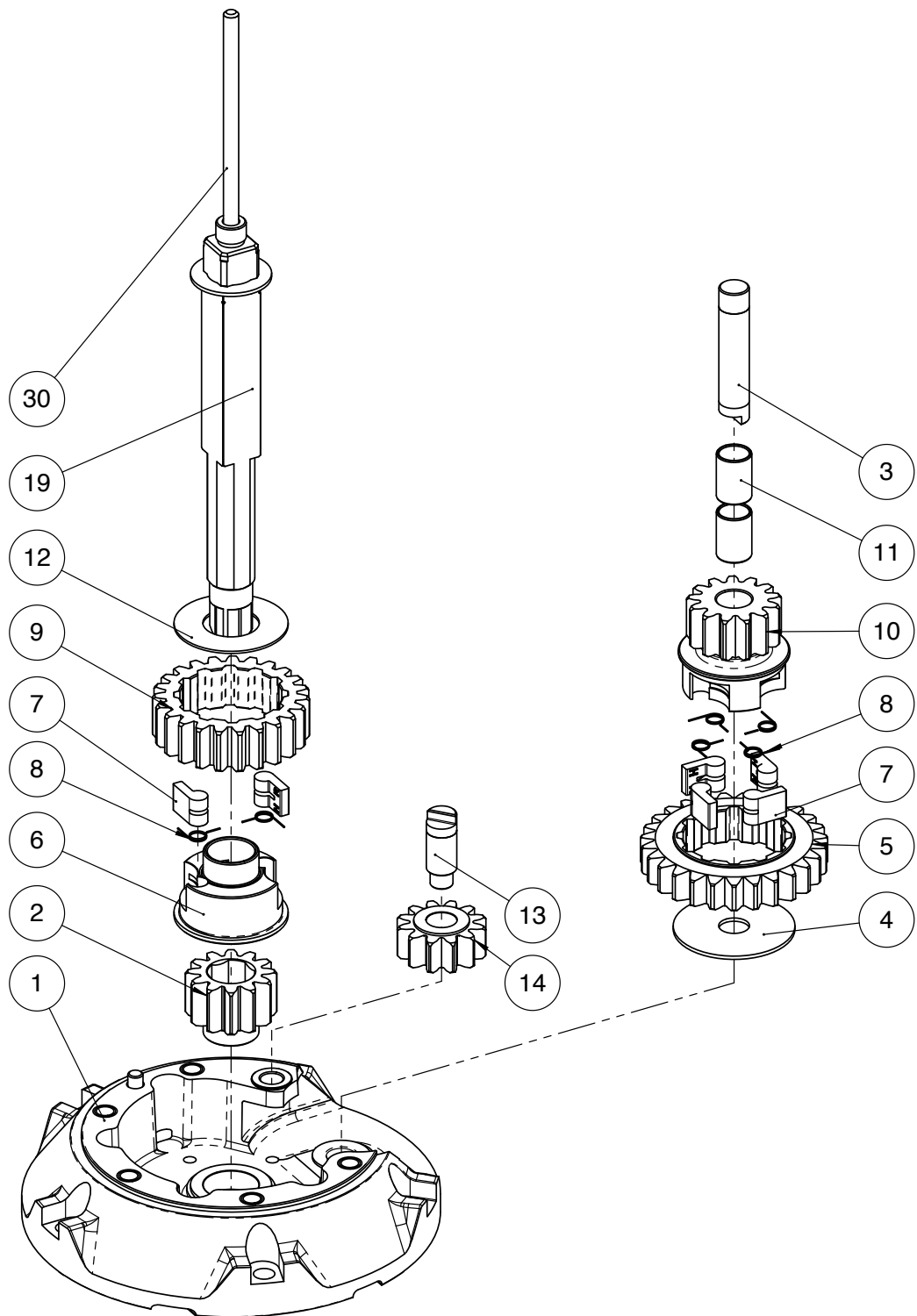

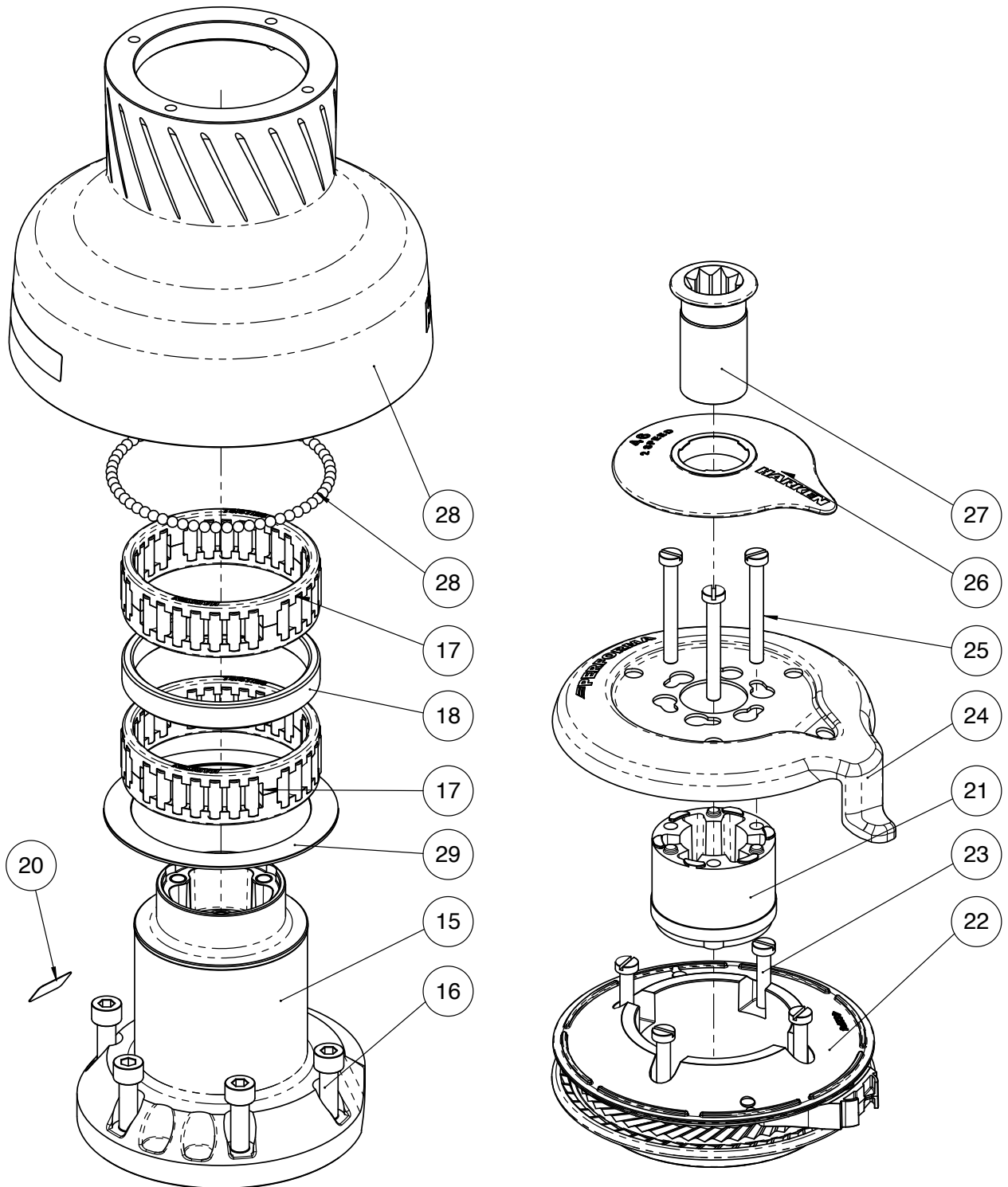

Performa Winch 46.2 STP E/HY

Pos	Q.ty	Code	Description	Pos	Q.ty	Code	Description
1	1	A 966339 00	PERFORMA Assy Base Winch 46 EL/HY <i>PERFORMA Base W46 Heli-coil M8x10 Roller Ø6x19 Bushing Ø22xØ25x8.5 Bushing Ø9xØ11x7 Bushing Ø12xØ14x11</i>	17	2	A 741337 00	Bearing Ø75xØ87x26*
2	1	S 41302 00 04	Gear Z12	18	1	S 41339 00 80	Spacer*
3	1	S 41330 00 04	Pin ø12x60	19	1	A 967770 00	Assy Central Shaft W46 EL/HY <i>Central Shaft W46 EL/HY Washer Ø17.2xØ32x1.5</i>
4	1	S278170002	Washer 12.5x48x1.5*	20	1	S 41876 00 63	Winch Serial Number Sticker
5	1	S 41326 00 04	Gear Z27	21	1	S 41294 00 A0	Stripper arm support
6	1	S 41426 00 04	Pawls Carrier Ø8xN2	22	1	A 965895 00	Performa Assy Jaws W46 <i>Lower Jaw W46 Performa Upper jaw W46 Peeler W46 - 50 SPRING</i>
7	6	S000090004	Pawl Ø 8*	23	4	M0601803	Vite UNI EN ISO 1207:1996 - M6x35 - A4*
8	6	S 00038 00 01	Pawl Spring dia 8*	24	1	S 65739 00 19	Performa Black Stripper Arm W46
9	1	S 41283 00 41	Gear Z23	25	3	M6007103	Screw M6x50 UNI6107*
10	1	S 41325 00 41	Pinion Z13	26	1	S 41270 00 A5	Cover 2 speed W46
11	2	M6017694	IGUS Bushing PSM-1214-20*	27	1	A 941493 00	Assieme Socket W35-80 EL/HY <i>Socket Handle W20/80 Washer ø25xø15x4 Nut Screw for Disconnect Rod O ring RC 2025 series</i>
12	1	S 41312 00 02	Washer Ø22.5xØ45x1*	28	1	A 965723 00	Performa W46 Drum <i>Performa Drum W46 Ball 3/16" Bearing ring W46 Winch Product Sticker**</i>
13	1	S 41307 00 04	Pin ø9-ø12x32.5	29	1	S 65730 00 52	Performa Shim W46
14	1	A 941334 00	Assy Gear Z12 <i>Gear Z12 Bushing Ø12xØ14x8</i>	30	1	S 41611 00 02	Disconnect Rod W46
15	1	A 941322 00	Assy Housing Winch 46 <i>Housing Winch 46 Bushing Ø12xØ14x8 Bushing Ø12xØ14x11 Heli-coil M6x9 Bushing for support</i>				
16	5	M0606303	Screw M8x25 UNI 5931*				

*Service kit available; see winch kit section on the website www.harken.com

**Winch product sticker



Horizontal electric motor

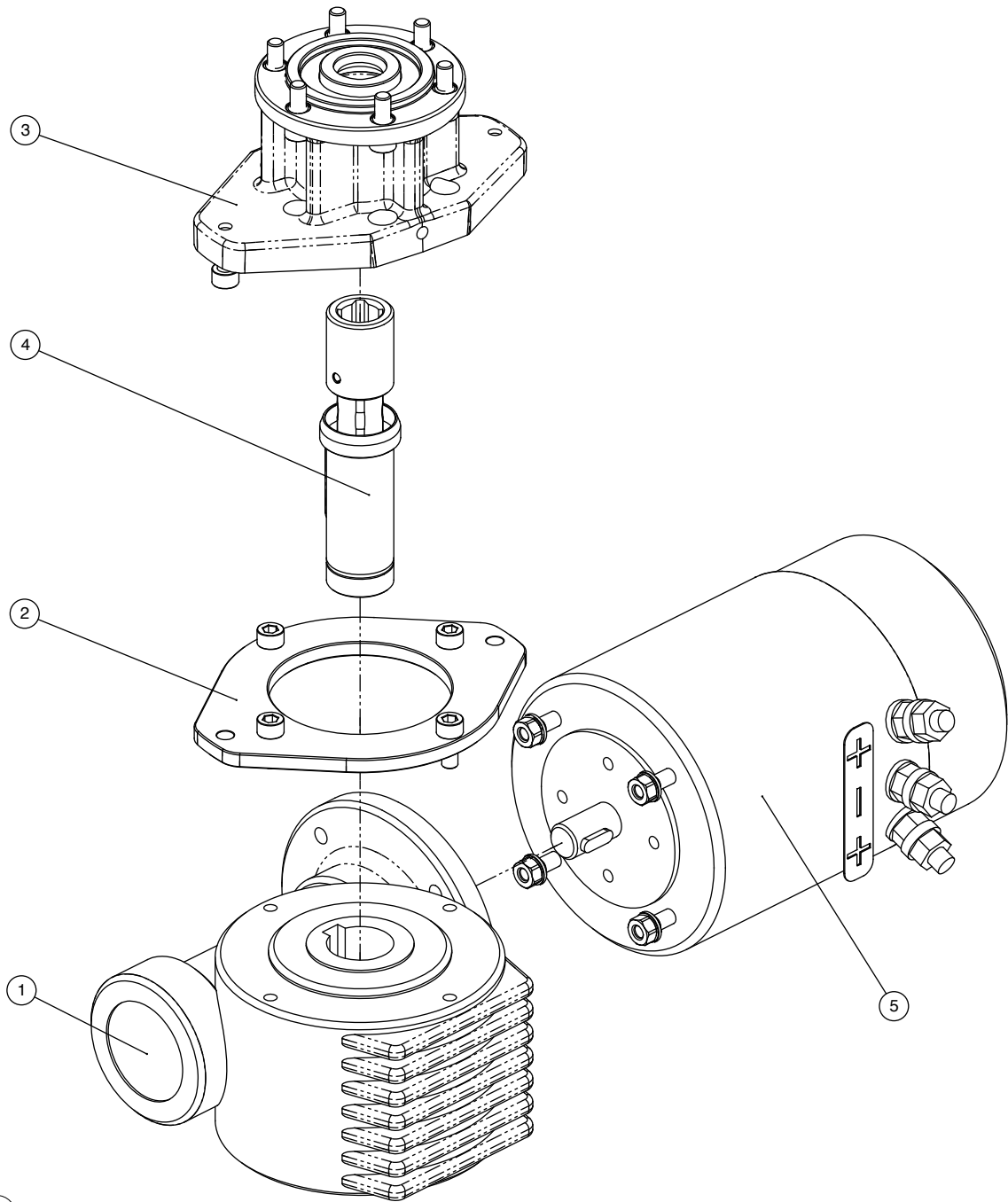

TOP VIEW

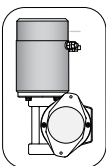

*** Motor installed in right-hand configuration.**

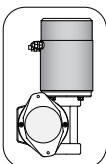

**** Motor installed in left-hand configuration.**

Pos	Q.ty	Code	Description
1	1	A 931279 00	KIT Gear Reduction VF49*
	1	A 941949 00	KIT LM Gear Reduction VF49**
2	1	A 941492 00	KIT Assy Electric Motor Flange
3	1	A 941495 00	KIT EL HO Motor Flange
4	1	A 965376 00	Performa KIT EL HO Motor Clutch
5	1	A 960154 00	KIT EL Motor 12V 0,7kW
	1	A 960157 00	KIT EL Motor 24V 0,9kW

Vertical electric motor

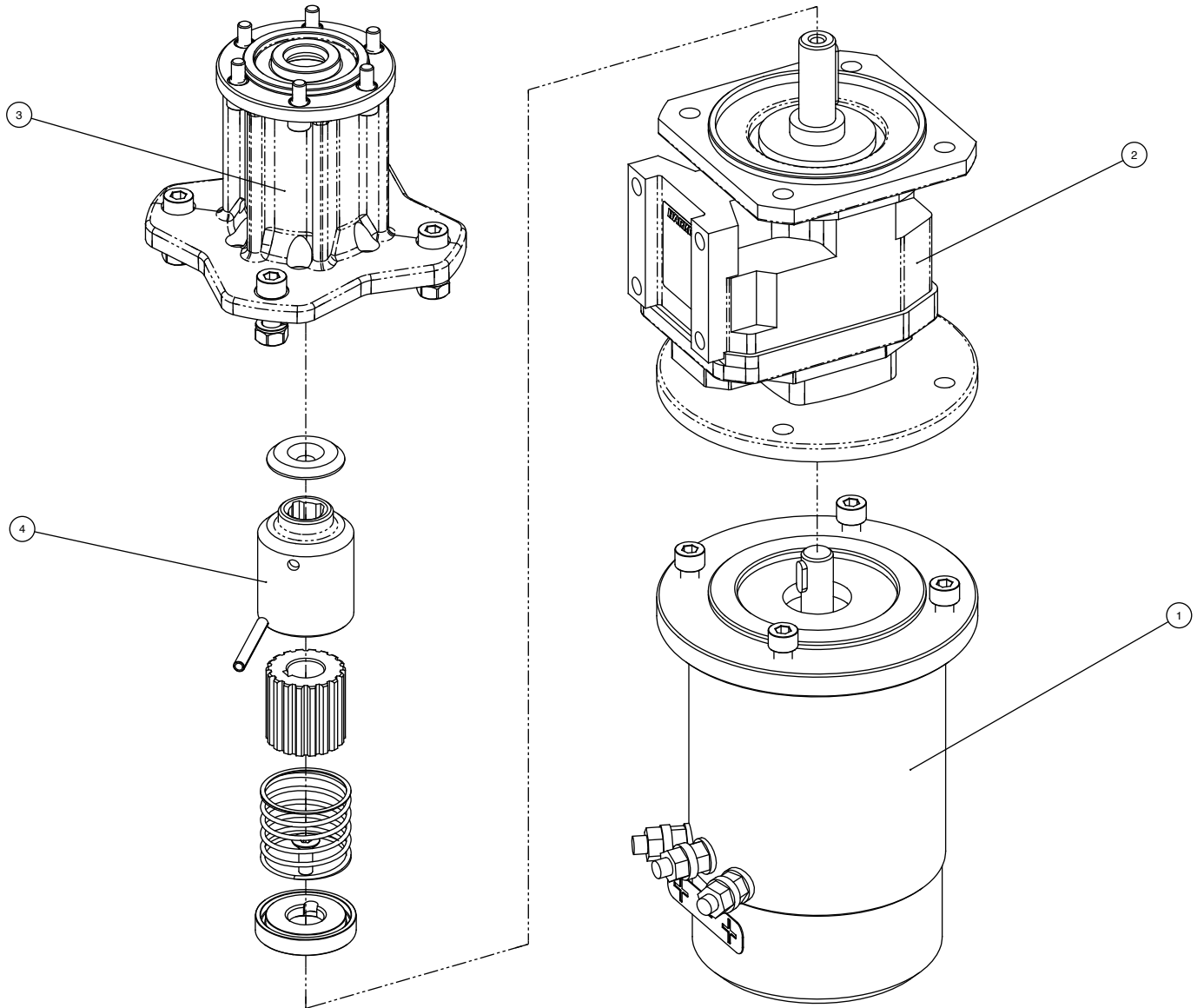

Pos	Q.ty	Code	Description
1	1	A 960105 00	KIT EL Motor 12V 1,5kW VT
	1	A 960104 00	KIT EL Motor 24V 2kW VT
2	1	A 965629 00	Vertical reduction gear box STM AMF1 35
3	1	A 941505 00	KIT EL VT Motor Flange
4	1	A 941937 00	KIT EL VT Motor Clutch

Hydraulic motor

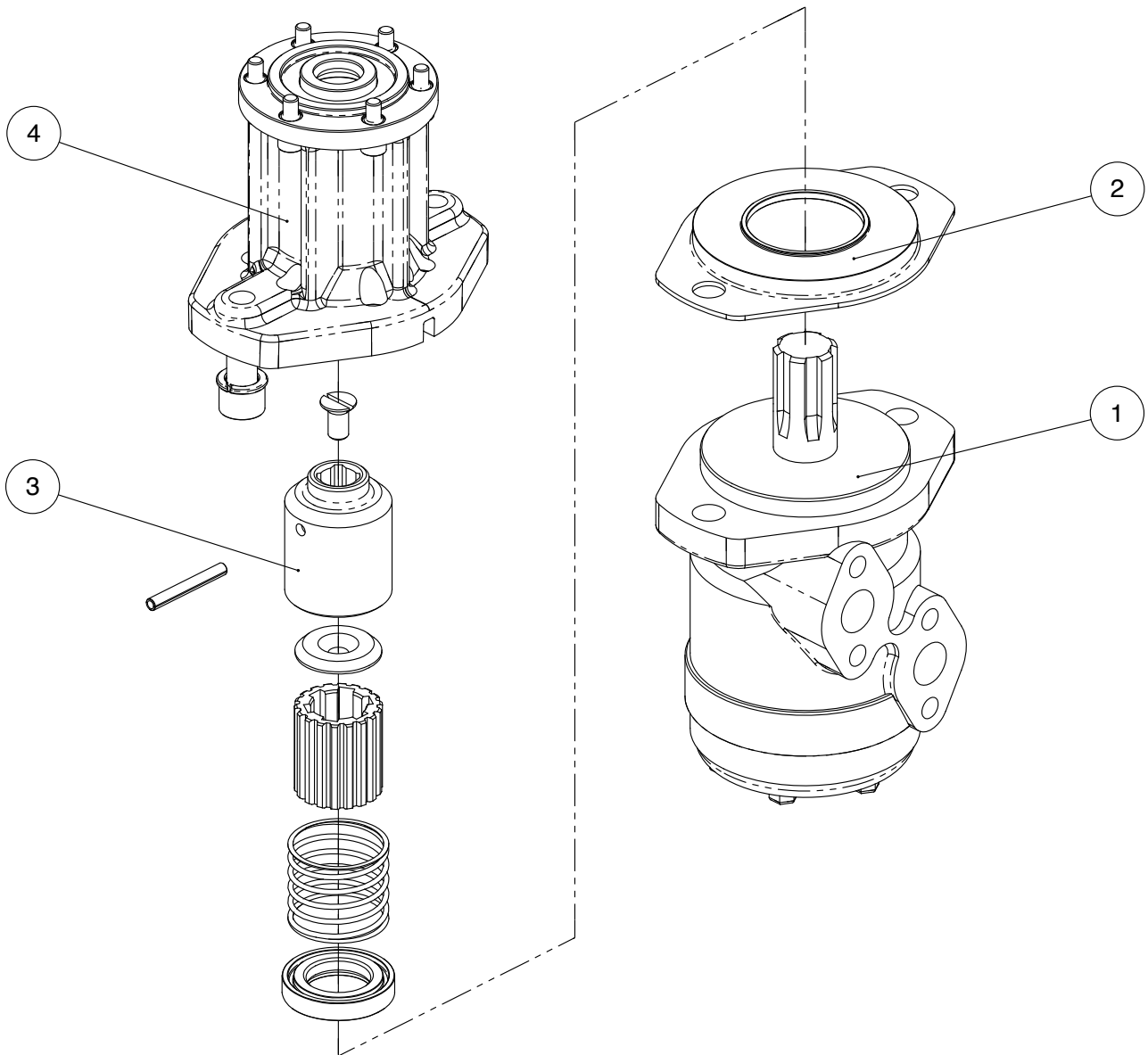

Pos	Q.ty	Code	Description
1	1	G45942000Y	Hydraulic motor *OMR50 151-0420 alb.scan. 1"
2	1	S 41500 00 80	Hydraulic Motor Spacer
3	1	A 941932 00	KIT Clutch HY Motor (OMR50)
4	1	A 941491 00	KIT HY Motor Flange (OMR50)