

Installation and Maintenance Manual

MRPW-F

Powered Performa™ Winch

46.2 STP EL/HY
46.2 STQP EL/HY



HARKEN®

Introduction	3
Technical characteristics	3
<i>Performance data</i>	3
<i>Weight</i>	5
<i>Maximum working load</i>	5
Technical characteristics - Winch Quattro Performa	4
<i>Performance data</i>	4
<i>Weight</i>	7
<i>Maximum working load</i>	7
Outline	5
<i>Winch 46.2 STP EL/HY</i>	5
<i>Horizontal electric motor</i>	5
<i>Vertical electric motor</i>	6
<i>Hydraulic electric motor</i>	6
Outline - Winch Quattro Performa	7
<i>Winch 46.2 STQP E/HY</i>	7
<i>Horizontal electric motor</i>	7
<i>Vertical electric motor</i>	8
<i>Hydraulic electric motor</i>	8
Installation	9
<i>Installation procedure</i>	10
<i>Winch installation procedure</i>	11
<i>Positioning the self-tailing arm</i>	13
<i>Motor installation procedure</i>	13
<i>Electric equipment</i>	14
<i>Hydraulic connections diagram</i>	16
Maintenance	17
<i>Washing</i>	17
<i>Maintenance table</i>	17
<i>Winch disassembly procedure</i>	17
<i>Winch exploded view with maintenance products</i>	21
<i>Winch assembly</i>	22
Harken® limited worldwide warranty	23
Ordering spare parts	23
Exploded view	24
<i>Performa Winch 46.2 STP EL/HY</i>	24
<i>Performa Winch 46.2 STQP EL/HY</i>	26
<i>Horizontal electric motor</i>	30
<i>Vertical electric motor</i>	31
<i>Hydraulic electric motor</i>	32
Parts list	28
<i>Performa Winch 46.2 STP EL/HY</i>	28
<i>Performa Winch 46.2 STQP EL/HY</i>	29
<i>Horizontal electric motor</i>	30
<i>Vertical electric motor</i>	31
<i>Hydraulic electric motor</i>	32

Introduction

This manual gives technical information on winch installation and maintenance, including disassembling and reassembling.

This information is DESTINED EXCLUSIVELY for specialised personnel or expert users.

Installation, disassembling and reassembling of the winch by personnel who are not experts may cause serious damage to users and those in the vicinity of the winch.

Harken® accepts no responsibility for defective installation or reassembly of its winches.

In case of doubt the Harken® Tech Service is at your disposal at techservice@harken.it

This Manual is available only in English. If you do not fully understand the English language, do not carry out the operations described in this Manual.

Technical characteristics

	Power ratio	Gear ratio
1st speed	11,70 : 1	2,30 : 1
2nd speed	46,50 : 1	9,17 : 1

The theoretical power ratio does not take friction into account.

Performance data

Winch 46.2 STP EL
(electric)

	horizontal motor				vertical motor			
	12 V (700 W)		24 V (900 W)		12 V (1500 W)		24 V (2000 W)	
	1st speed	2nd speed	1st speed	2nd speed	1st speed	2nd speed	1st speed	2nd speed
line speed (m/min)**	26,7	6,7	33,5	8,4	35,1	8,8	42,3	10,7
max load (Kg)	315	1300	315	1300	315	1300	315	1300

**Line speed is measured with no load

winch 46.2 STP EL		motor nominal power (W)		current absorption at winch MWL (A)	
		12 V	24 V	12 V	24 V
		horizontal	vertical	horizontal	vertical
	horizontal	700	900	180	140
	vertical	1500	2000	220	120

Winch 46.2 STP HY
(hydraulic)

	1st speed	2nd speed
line speed (m/min)*	52,5	13,2
max load (Kg)***	315	1300

* at 20 L/min oil flow (5,28 Gall/min)

*** at 120 bar a 20 L/min

NOTE

The ratio the line load - pressure are evaluated at flow 20 l/min,

at different flow the line load - pressure ratio change and it's minimum at motor stall.

The pressure on the graph it's the pressure drop between in and out motor ports.

The performance are evaluated measuring the pressure and flow on the motor ports.

Performance data based on oli with a viscosity of 35mm²/s [165 SUS] and temperature of 50° [120° F]

Technical characteristics - Winch Quattro Performa

Dual Drum Winch: upper drum and lower drum.

LD refers to the lower drum

See page 7 for dimensions

	Power ratio	Power ratio LD	Gear ratio
1st speed	11,70 : 1	6,23 : 1	2,30 : 1
2nd speed	46,60 : 1	24,79 : 1	9,17 : 1

The theoretical power ratio does not take friction into account.

Performance data

Winch 46.2 STQP EL
(electric)

	horizontal motor				vertical motor			
	12 V (700 W)		24 V (900 W)		12 V (1500 W)		24 V (2000 W)	
	1st speed	2nd speed	1st speed	2nd speed	1st speed	2nd speed	1st speed	2nd speed
line speed (m/min)**	26,7	6,7	33,15	8,4	35,1	8,8	42,3	10,7
max load (Kg)	315	1300	315	1300	315	1300	315	1300
line speed LD (m/min)**	8,5	3,5	17,1	4,7	29	7,4	41,6	10,4
max load LD (Kg)	200	500	200	500	200	500	200	500

**Line speed is measured with no load

winch 46.2 STQP EL		motor nominal power (W)		current absorption at winch MWL (A)	
		12 V	24 V	12 V	24 V
		horizontal	700	900	180
	vertical	1500	2000	220	120

Winch 46.2 STQP HY
(hydraulic)

	1st speed	2nd speed
line speed (m/min)*	52,15	13,2
max load (Kg)***	315	1300
line speed LD (m/min)*	98,7	24,8
max load LD (Kg)***	160	500

* at 20 L/min oil flow (5,28 Gal/min)

*** at 120 bar a 20 L/min

NOTE

The ratio the line load - pressure are evaluated at flow 20 l/min, at different flow the line load - pressure ratio change and it's minimum at motor stall.
The pressure on the graph it's the pressure drop between in and out motor ports.
The performance are evaluated measuring the pressure and flow on the motor ports.
Performance data based on oli with a viscosity of 35mm²/s [165 SUS] and temperature of 50° [120° F]

Weight

	ST EH	ST EV	ST H
weight (Kg)	14,9	16,7	12,7

Versions:

EH = horizontal electric winch

EV = vertical electric winch

H = vertical hydraulic winch

Maximum working load



WARNING!

The maximum working load (MWL) for the 46.2 ST Performa™ Winch is 1300 Kg (2866 lb). Subjecting the winch to loads above the maximum working load can cause the winch to fail or pull off the deck suddenly and unexpectedly during high loads causing severe injury or death.

Outline

Winch 46.2 STP EL/HY

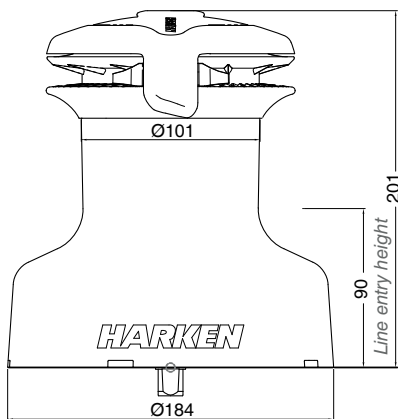

Horizontal electric motor (12 V / 24 V)

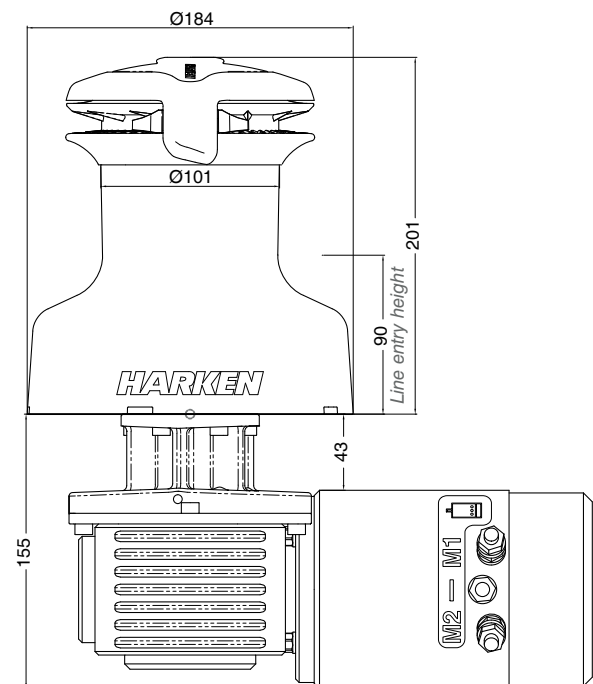

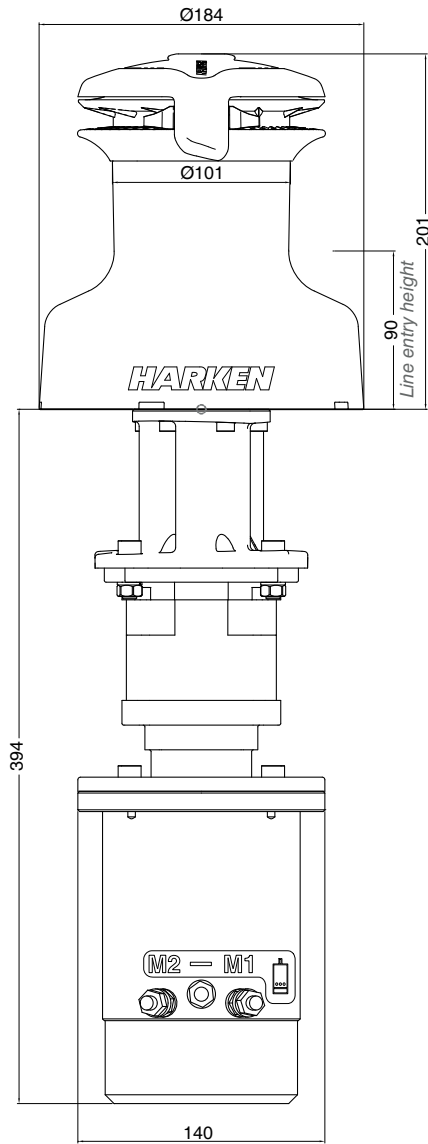
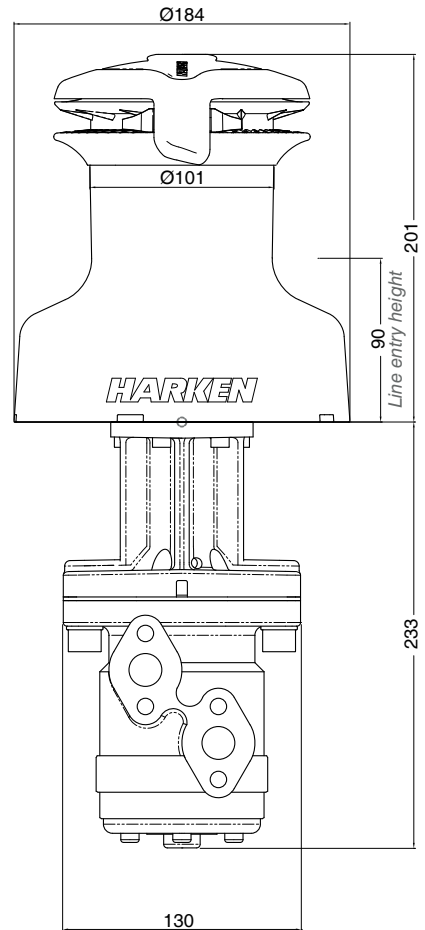
Vertical electric motor (12 V / 24 V)Hydraulic motor

Weight

	ST EH	ST EV	ST H
weight (Kg)	15,9	17,7	13,7

Versions:

EH = horizontal electric winch

EV = vertical electric winch

H = vertical hydraulic winch

Maximum working load



The maximum working load (MWL) for the 46.2 ST Performa™ Winch is 1300 Kg (2866 lb).

The maximum working load (MWL) for the 46.2 STQP Performa™ Winch relative to the lower drum is 500 Kg (1102 lb).

Subjecting the winch to loads above the maximum working load can cause the winch to fail or pull off the deck suddenly and unexpectedly during high loads causing severe injury or death.

Outline

Winch 46.2 STQP EL/HY

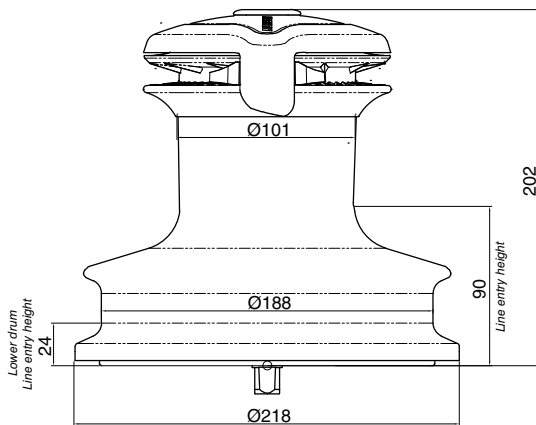

Horizontal electric motor (12 V / 24 V)

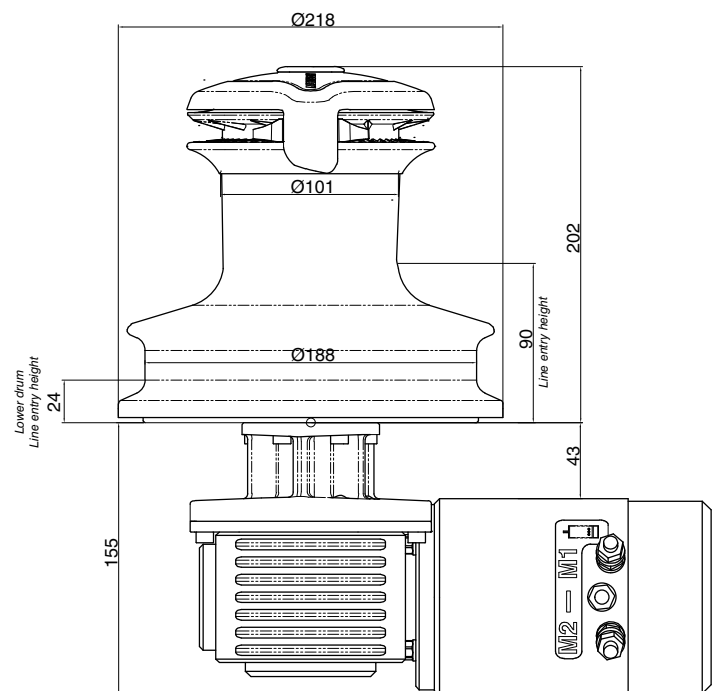

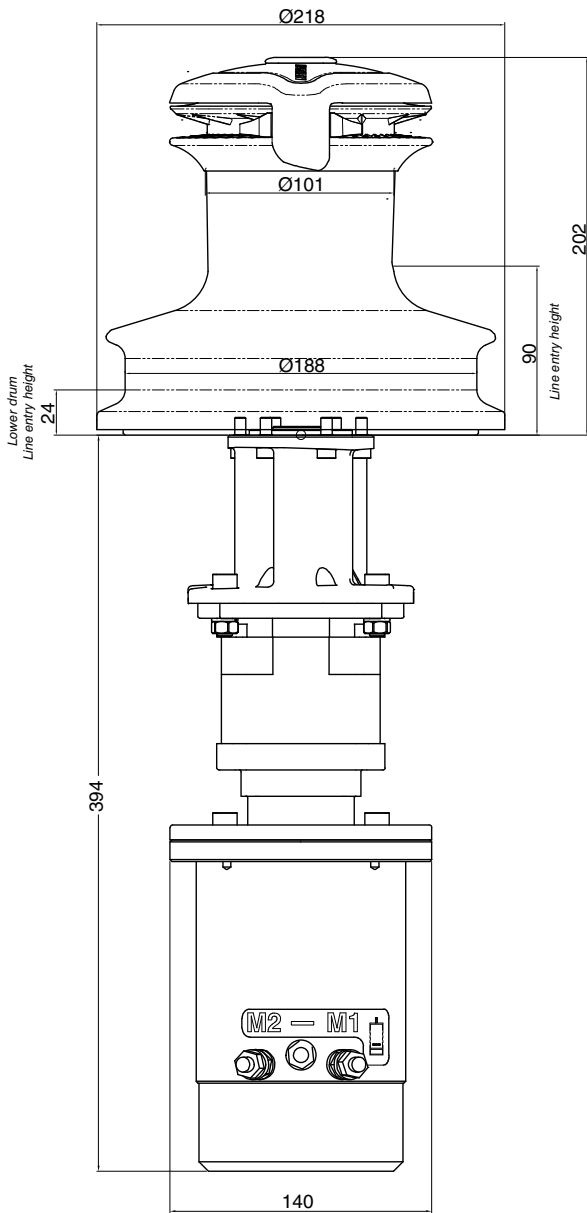
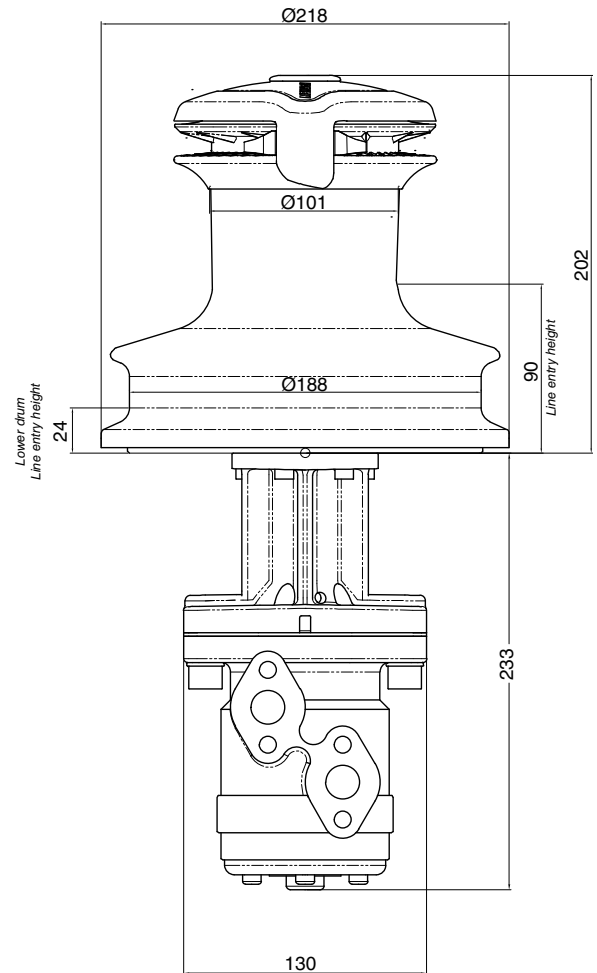
Vertical electric motor (12 V / 24 V)Hydraulic motor

Installation

The winch must be installed on a flat area of the deck, reinforced if necessary to bear a load equal to at least twice the maximum working load of the winch.

It is the installer's responsibility to carry out all structural tests needed to ensure that the deck can bear the load.

Harken® does not supply the screws needed to install the winch since these may vary depending on the deck on which it is to be installed.

It is the installer's responsibility to choose the correct screws taking account of the loads they will have to bear.

Harken® assumes no responsibility for incorrect installation of its winches or for an incorrect choice of mounting screws.

DANGER!

Incorrect installation of the winch may cause severe injury or death. Consult the yard that built the boat in the case of doubt over the correct positioning of the winch.



WARNING!

Failure to use the correct number and type of mounting fasteners or failure to ensure the correct deck strength can result in the winch pulling off the deck suddenly and unexpectedly during high loads causing severe injury or death.



WARNING!

Verify the entry angle of the sheet. This must be 8° with tolerance of $\pm 2^\circ$, to avoid sheet overrides and damaging the winch or making the winch inoperable leading to loss of control of the boat which can lead to severe injury or death.

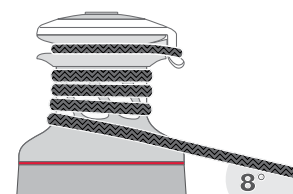

WARNING!

Mount the winch on the deck so that the drive gear is positioned where the sheet enters the winch drum. Incorrect position of drive gear can weaken winch leading to failure which can cause an accident leading to severe injury or death.

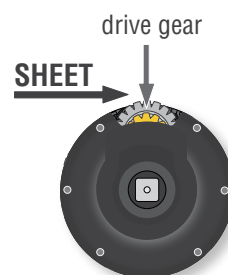

After correctly positioning the final pinion with respect to the load, check that the motor, gearing, electrical wiring and/or hydraulic pipes can be housed below decks. To help find the optimal compromise, remember that, to make the installation of the motor easier, it can be coupled to the winch in different positions.

Once you have decided the correct mounting position for the winch on the deck and checked the space available below deck, proceed with the installation.

Procedure

To install the winch, remove the drum and use Socket Head (SH) bolts.

Tools needed

 One medium flat-bladed screwdriver

To identify the various parts, refer to the exploded view at the end of this Manual.

 Torque to apply when assembling



1. Pull out the disconnect rod n°30



2. Unscrew the central screw ($\approx 2\text{Nm}/18\text{ in-lb}$)



3. Slide off the assy socket n°27 and the cover n°26.
Pay attention to the o-ring in the socket.



4. Unscrew the three screws n°25
($\approx 4\text{Nm}/35\text{ in-lb}$)



5. Remove the stripper arm n°24 by
rotating and lifting it.



6. Lift off the drum n°28

Install the winch on the deck in the position you have chosen, keeping in mind the limits described on page 5.

Winch installation procedure

Carry out the **Procedure**, then install the winch on the deck in the chosen position.

NOTICE

Before drilling the deck, check the space available below deck for the flange and the motor

- A.** Position the base of the winch on the deck and mark the position of the holes or use the drilling cut-out template at the point where you have decided to place the winch.
- B.** Remove the winch and drill the five 8.2 mm diameter holes.

Below is a reduced scale diagram.

The drilling cut out template is available on the Harken® website, www.harken.com

Winch STP

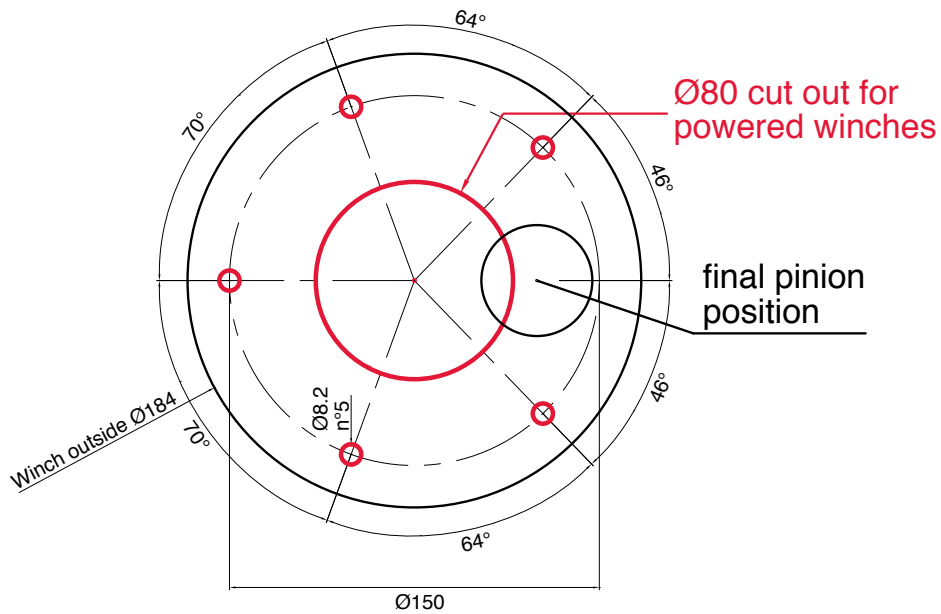

Winch STQP

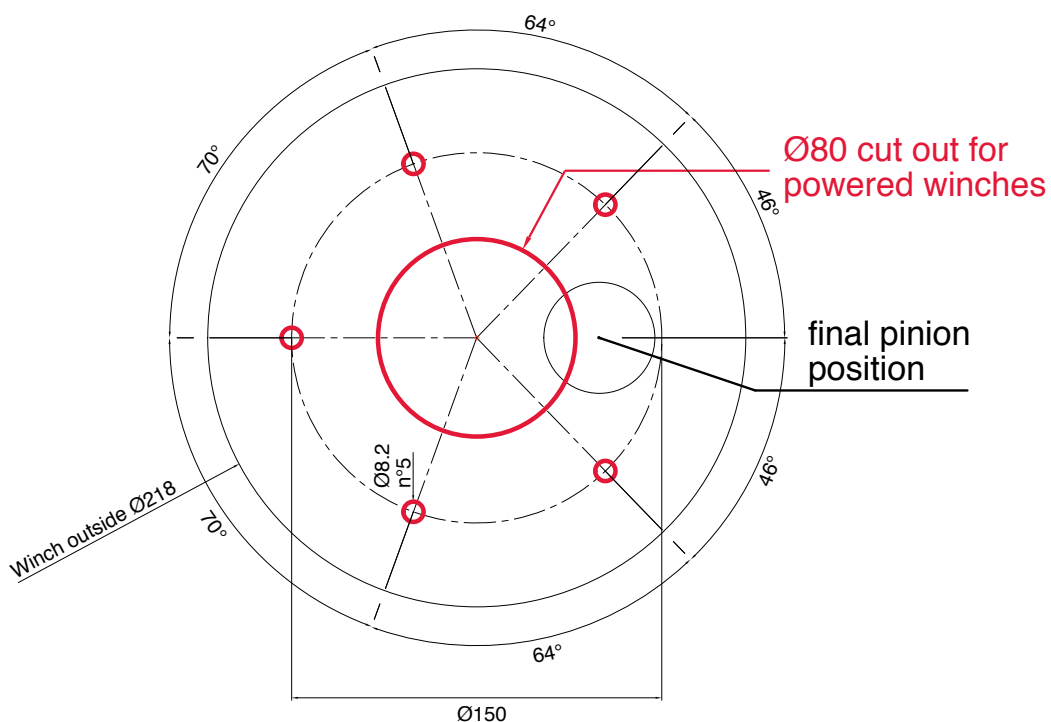

- C. Bolt the base of the winch to the deck using five M8 Socket Head (SH) bolts (no supplied by Harken®), correctly chosen for the thickness and type of the boat deck. Consult the yard that built the boat in case of doubt.

**WARNING!**

To install the winch on the deck, use only bolts in A4 stainless steel (DIN 267 part11). Bolts made of other materials may not have sufficient strength or may corrode which can result in winch pulling off deck suddenly and unexpectedly during high loads causing severe injury or death.

NOTICE

To mount winches on the deck, do not use countersunk bolts.

- D. Fill the mounting holes with a suitable marine sealant.
- E. Remove the excess adhesive/sealant from the holes and base drainage channels
- F. Reassemble the winch following the steps of the **Procedure** in the reverse order, and apply the products indicated in the section on maintenance.

NOTICE

Before closing the winch, make sure the holes and drainage channels in the base of the winch are not obstructed.

Positioning the self-tailing arm

Position the self-tailing arm so that the line leaving the winch is led into the cockpit.

Motor installation procedure







WARNING!

Make sure that the power is switched off before installing or carrying out maintenance on the winch.

Once you have installed the winch on the deck, proceed with motor installation. The motor can be coupled to the winch in different positions. Check the space available below deck and choose the suitable position.

Tools needed

-  A number five hex key
-  A number six hex key (only for vertical electric motor)
-  A number ten hex key (only for hydraulic motor)
-  Two number thirteen wrenches



1. Position the flange (see Page 10)



2. Tighten six M6 precote coated screws (8 Nm/ 71 in-lb)



3. Position the reduction gear and motor



4. Tighten the two screws (8 Nm/ 71in-lb). Be sure to align the flange.

NOTICE

Before positioning the flange, check to make sure that seal is seated correctly.



After winch is assembled and before sailing, test the powered winch functioning: insert the lock-in winch handle in the handle socket and check that the disconnect rod must disconnect gearbox.

Electric equipment

To guarantee greater efficiency in terms of safety and long life, for every winch model is mandatory to install the Dual Function Control Box.

To fasten the Dual Function Control Box containing solenoids to bulkhead or wall, for all installation details and for all electric wiring schemes, refer to the Dual Function Control Box manual.



WARNING!

Before installing and using the device, read carefully the Dual Function Control Box manual available on web site www.harken.com

Refer to the following chart for wire size:

Total distance between winch and battery

Winch size	Current voltage	Under 16.4 ft AWG	Under 5 m mm ²	16.4 - 32.8 ft AWG	5 m - 10 m mm ²	32.8 - 49.2 ft AWG	10 m - 15 m mm ²	49.2 - 65.6 ft AGW	15m - 20 m mm ²
46.2	12 V	2	32	0	50	00	70	000	95
46.2	24 V	5	16	3	25	2	35	0	50

Refer to the following chart for HCP model:

Winch size	Current voltage	HCP model	Ampere rating
46.2	12 V	HCP1717	80A
46.2	24 V	HCP1717	80A

NOTICE

To connect motor, attach cable terminals to clamps between nut and lock nut. Hold nut in contact with motor using a spanner and tighten other nut with second spanner. Take special care not to turn the central spindles. These instructions apply when assembling and disassembling. We recommend using a torque wrench so as to obtain a torque equal to and no greater than 10 Nm (88 in-lb).

**NOTICE**

Note that correct electrical contact sequence is:
Nut – Cable Terminal – Self-Locking Washer – Lock Nut



Hydraulic connections diagram

The hydraulic motor must be connected to a hydraulic system using two high-pressure tubes which serve for input or output according to the direction in which the motor will be run. The motor also needs a third connection with a low pressure tube for drainage, so that excess oil can return to the main tank to avoid shortening the life of the motor. This motor uses an open centre valve.

Refer to the following chart for the hydraulic system:

For the hydraulic motor:

Input/output pipe thread: G 1/2 – depth 15 mm

Drainage pipe thread: G 1/4 – depth 12 mm

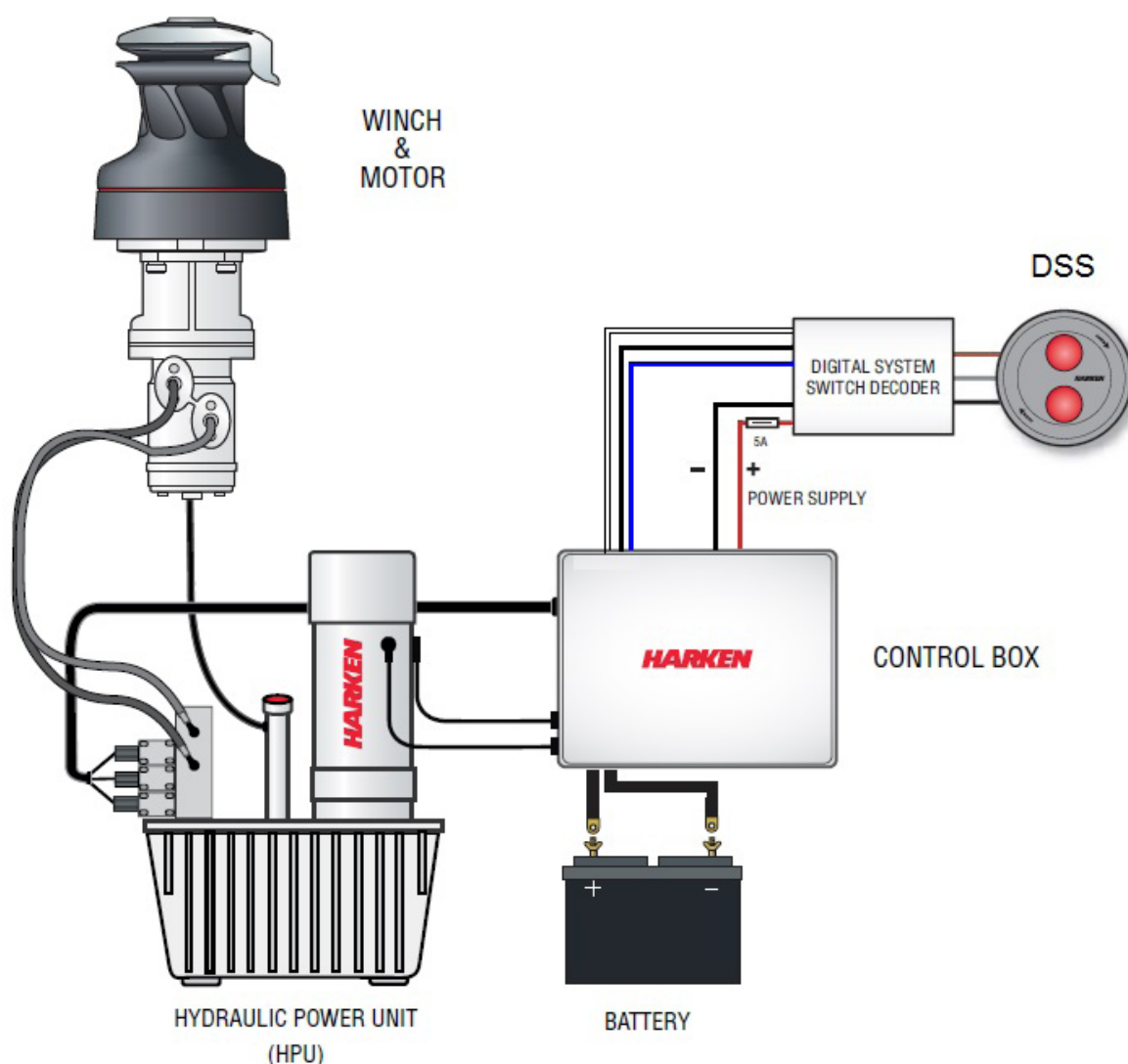
**WARNING!**

Refer to the Hydraulic Power Unit and Control Box manual.

**WARNING!**

Refer to the Digital System Switch manual.

Maintenance

Washing

Winches must be washed frequently with fresh water, and in any case after each use.

Do not allow teak cleaning products or other cleaners containing caustic solutions to come into contact with winches and especially anodised, chrome plated or plastic parts.

Do not use solvents, polishes or abrasive pastes on the logos, on the stickers on the winches or on any anodized, chrome plated and plastic surfaces.

Make sure that the holes and drainage channels in the base of the winch are not obstructed so that water does not collect.

Maintenance table

Winches must be visually inspected at the beginning and end of every season of sailing or racing. In addition they must be completely overhauled, cleaned and lubricated at least every 12 months. After an inspection, replace worn or damaged components. Do not replace or modify any part of the winch with a part that is not original.



WARNING!

Periodic maintenance must be carried out regularly. Lack of adequate maintenance shortens the life of the winch, can cause serious injury and also invalidate the winch warranty. Installation and maintenance of winches must be carried out exclusively by specialized personnel.

In the case of doubt contact Harken® Tech Service at techservice@harken.it



WARNING!

Make sure that the power is switched off before installing or carrying out maintenance on the winch.

Winch disassembly procedure

Tools needed



One medium flat-bladed screwdriver



A number five hex key



Brush

Rags

 Torque to be applied in assembly phase

To identify the various parts refer to the exploded view at the end of this Manual.

Carry out procedure as shown in the paragraph on winch installation and then do the following:



7. Completely unscrew the three screws n° 25 and remove the stripper arm support n°21



8. Slide out the central shaft n°19



9. Unscrew the 5 hex screws n°16
(\approx 20Nm/177 in-lb)

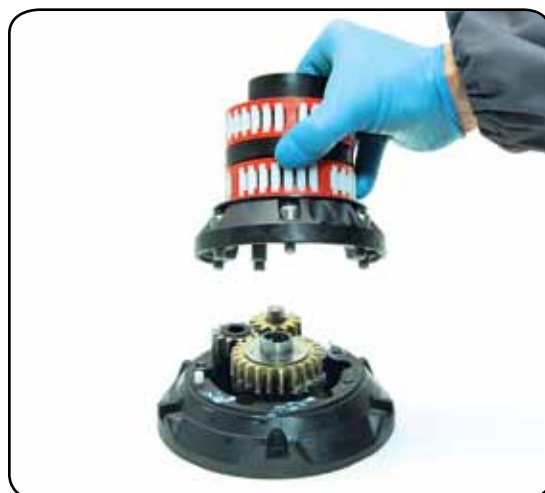

10. Remove the assy housing n°15
Important: washer n°12 may remain inside the drum support!



11. Remove the gear n°14



12. Remove the washer n°12



13. Remove the gearing n°9 and remove the pawls n°7. To facilitate the operation press the spring against the pawl with a blade.

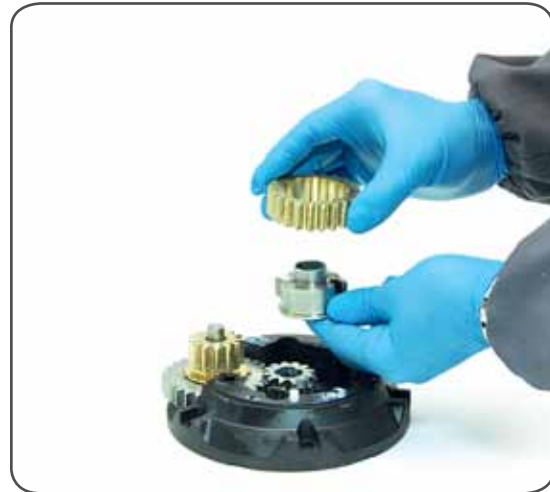

14. Slide off gear n°2



15. Remove the pinion n°10.



16. Slide off gear n°5



17. Remove the washer n°4.

If it is necessary to replace any **jaws** of the winch, proceed as follows:



I. Unscrew the 4 screws n°23
($\approx 4\text{Nm}/35\text{ in-lb}$)



II. Remove the jaws n°22

Inspect balls inside the drum and carefully check the correct position; if it is necessary to put back any balls, push balls in the race (as shown below):



Once the winch is completely disassembled, clean the parts with a degreasing that does not leave residues, proper to clean metal components; rinse plastic parts in fresh water. Once you have done this, dry the parts with cloths that do not leave residue.

Inspect gears, bearings, pins and pawls for any signs of wear or corrosion.

Carefully check the teeth of gears and ring gears to make sure there are no traces of wear.

Check the roller bearings and check there are no breaks in the bearing cages.

Replace worn or damaged components.

Carry out maintenance on components using the products listed below.

For more information on which products to use where, refer to the exploded diagram below.

Use a brush to lightly lubricate all gears, gear pins, teeth and all moving parts with grease.

Lightly lubricate the pawls and springs with oil. Do not use grease on the pawls!

Winch exploded view with maintenance products

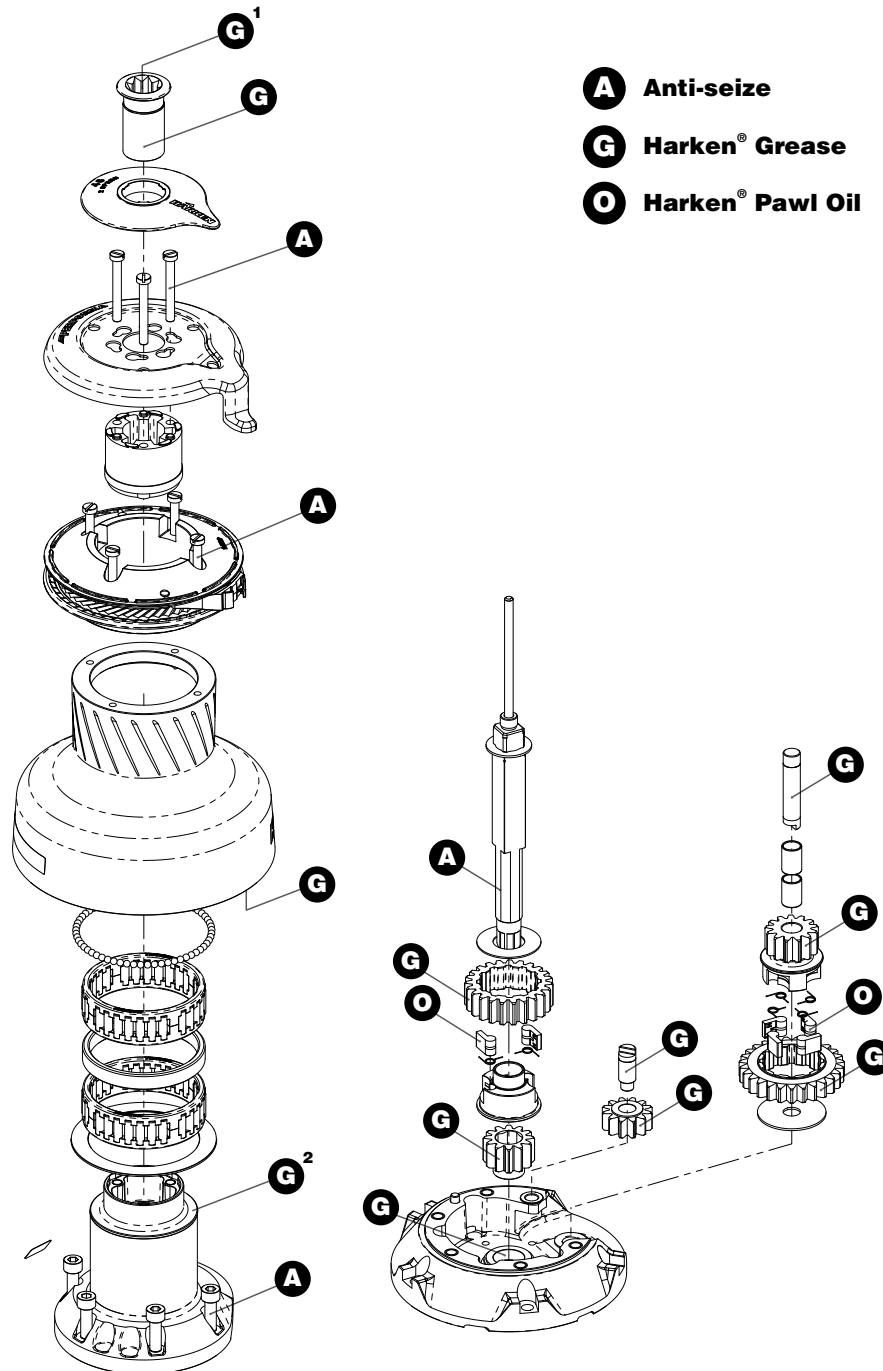

Apply Harken® grease where indicated above
 Apply Harken® grease: 1. on assy socket screw - 2. on drum gear

NOTICE

On every gear and every component that must be greased, apply Harken® grease with a brush in a proper quantity as shown below:



NOTICE

Harken® grease to apply on all teeth: do not use excessive quantity of product to void wastes. If in contact with the pawls, an excess of grease can compromise the safety of the winch.

Winch assembly

Make sure that the holes and drainage channels in the base of the winch are not obstructed. Assemble the winch in the reverse order of the sequence in the section on disassembly.

To tighten bolts, use the torque indicated in the disassembly procedure.



If the jaws have been disassembled, insert peeler between the two jaws, taking care that the letters TOP on the peeler are facing upwards.



When positioning the stripper arm, align the peeler with it.

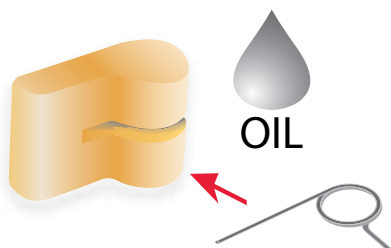

To assemble the pawls:

correctly position the spring in its housing as shown at left. Hold the spring closed and slide the pawl into its housing. Once in position, check that the pawls can be easily opened and closed with a finger.

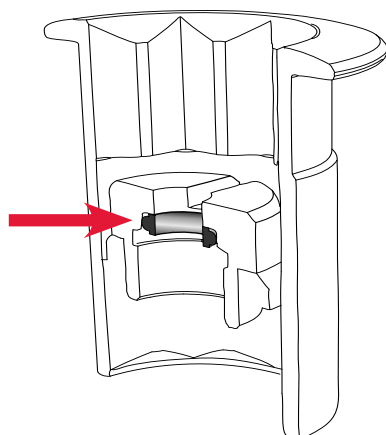

NOTICE

Before screw the central screw, check the correct position of the o-ring in the assy socket and apply Harken® grease.

In case of doubt concerning the assembly procedure contact Harken® Tech Service: techservice@harken.it

Harken® limited worldwide warranty

Refer to the Harken® Limited Worldwide Warranty in the Harken® Catalogue and on the website www.harken.com

Ordering spare parts

Spare parts can be requested from Harken® as described in the Harken® Limited Worldwide Warranty, indicating the part number in the Parts List and including the serial number of the winch for which the parts are required.

The serial number of the winch is printed on a plate on the drum support of the winch.



Manufacturer

Harken® Italy S.p.A.

Via Marco Biagi, 14
22070 Limido Comasco (CO) Italy
Tel: (+39) 031.3523511
Fax: (+39) 031.3520031
Email: info@harken.it
Web: www.harken.com

- **Tech Service**
Email: techservice@harken.it
- **Customer Service**
Tel: (+39) 031.3523511
Email: info@harken.it

Headquarters

Harken®, Inc.

1251 East Wisconsin Avenue
Pewaukee, Wisconsin 53072-3755 USA
Tel: (262) 691.3320
Fax: (262) 691.3008
Email: harken@harken.com
Web: www.harken.com

- **Tech Service**
Email: technicalservice@harken.com
- **Customer Service**
Tel: (262) 691-3320
Email: customerservice@harken.com

Performa Winch 46.2 STP EL/HY

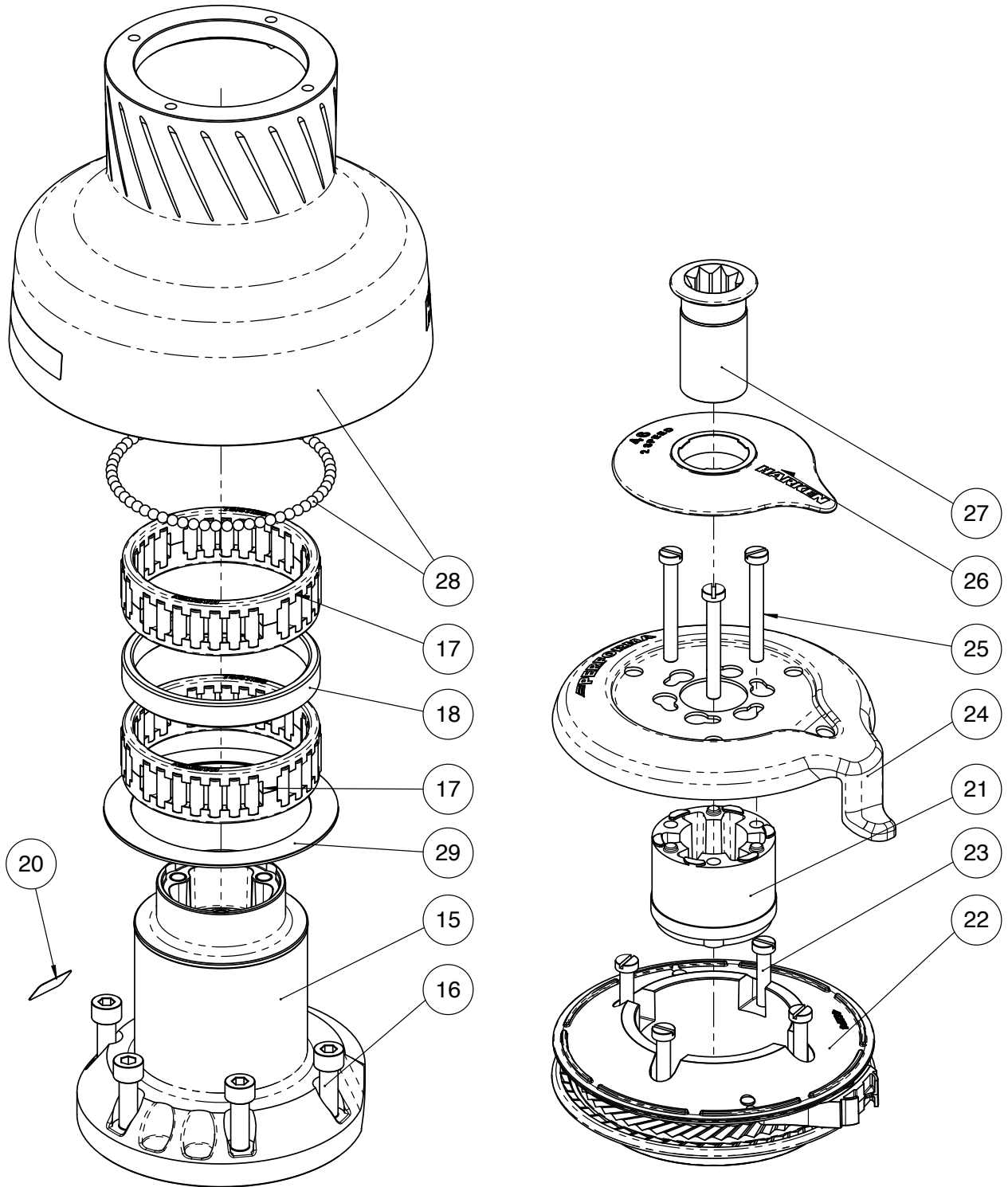

Performa Winch 46.2 STP EL/HY

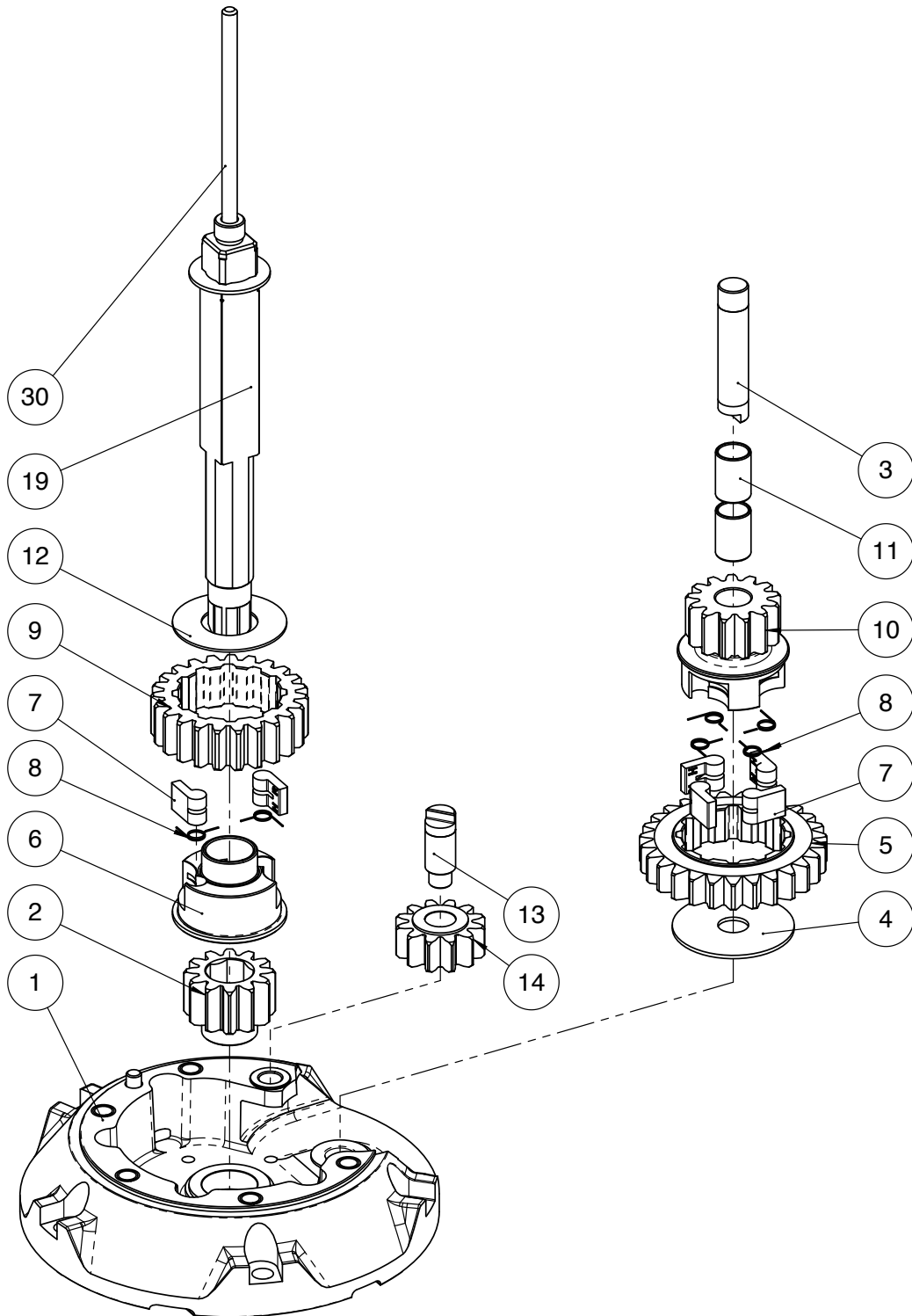

Performa Winch 46.2 STQP EL/HY

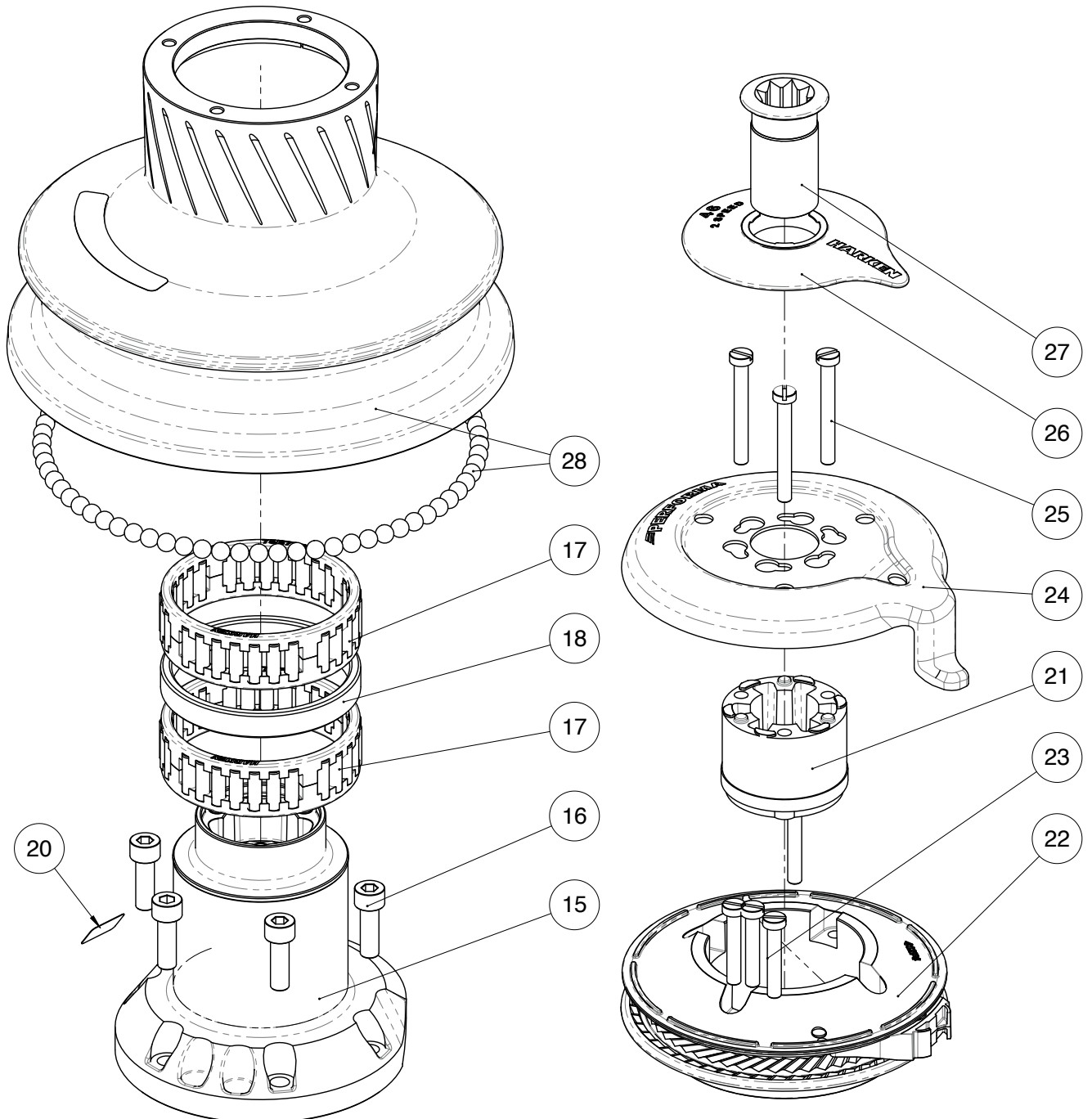

Performa Winch 46.2 STQP EL/HY

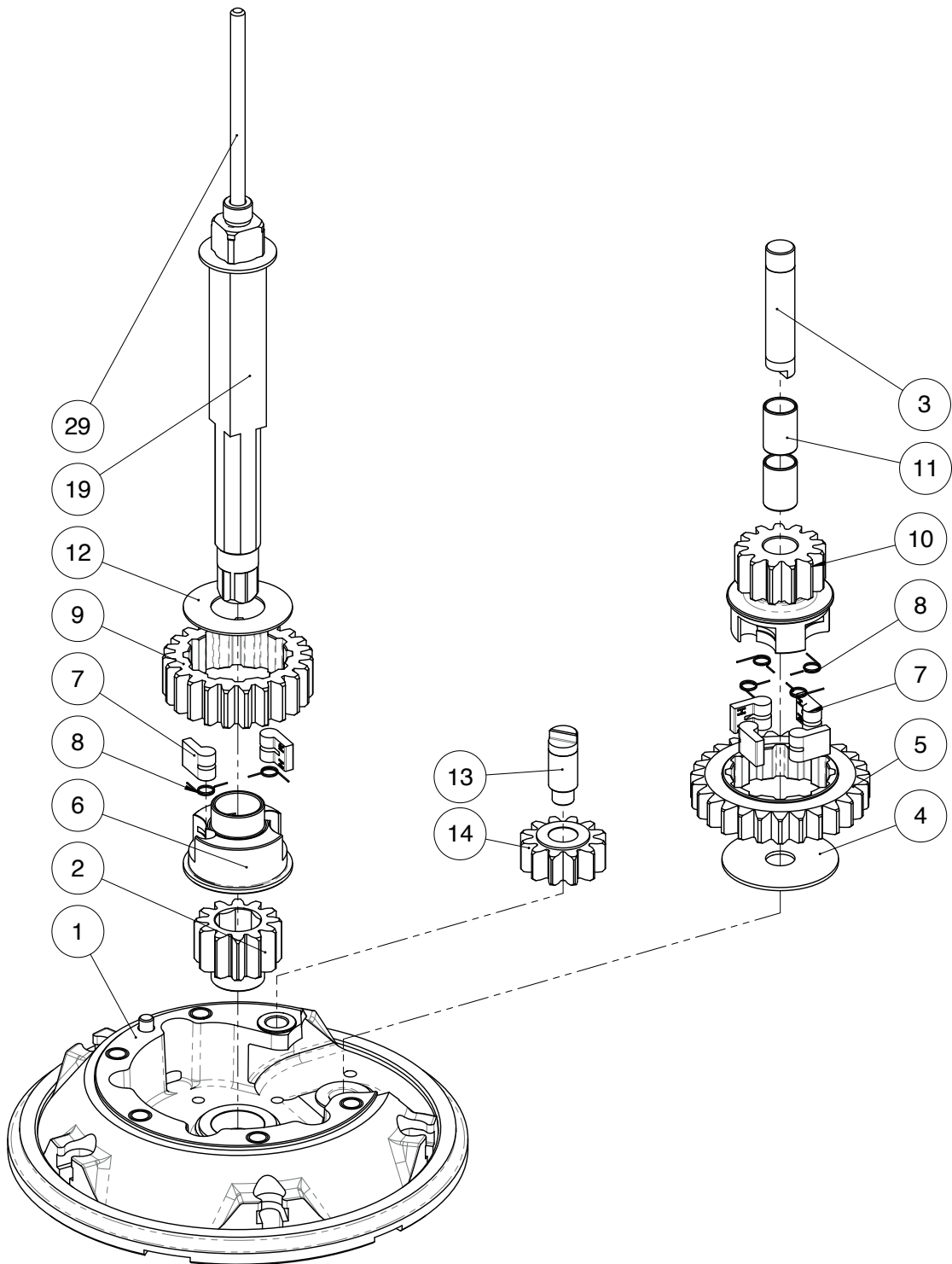

Performa Winch 46.2 STP EL/HY

Pos	Q.ty	Code	Description	Pos	Q.ty	Code	Description
1	1	A96633900	Performa Assy Base Winch 46 EL/HY	18	1	S413390080	Spacer
	1	S413350080	Performa Base W46	19	1	A96777000	Assy Central Shaft W46 EL/HY
	1	S4130900A7	Roller Ø6x19		1	S413880002	Central Shaft W46 EL/HY
	1	S414890080	Bushing Ø22xØ25x8.5				Washer Ø17.2xØ32x1.5
	1	S413330085	Bushing Ø9xØ11x7	20	1		Winch Serial Number Sticker
	1	S413330085	Bushing Ø12xØ14x11	21	1	S4129400A0	Stripper arm support
2	1	S413020004	Gear Z12	22	1	A96589500	Performa Assy Jaws W46
3	1	S413300004	Pin Ø12x60				Lower Jaw W46
4	1	S278170002	Washer Ø12.5xØ48x1.5				Performa Upper jaw W46
5	1	S413260004	Gear Z27		1	S414280080	Peeler W46 - 50
6	1	S414260004	Pawls Carrier Ø8xN2		4	S385970001	Spring
7	6	S000090004	Pawl Ø8*	23	4	M0601803	Screw UNI EN ISO 1207 - M6x35 - A4
8	6	S000380001	Pawl Spring Ø8*	24	1	S657390019	Performa Black Stripper Arm W46
9	1	S412830041	Gear Z23	25	3	M6007103	Screw M6x50 UNI6107
10	1	S413250041	Pinion Z13	26	1	S4127000A5	Cover 2 speed W46
11	2	M6017694	Bushing PSM-1214-20	27	1	A94149300	Assy Socket W35-80 EL/HY
12	1	S413120002	Washer Ø22.5xØ45x1				Socket Handle W20/80
13	1	S413070004	Pin Ø9xØ12x32.5		1	S414940085	Washer Ø25xØ15x4
14	1	A94133400	Assy Gear Z12		1	S414930003	Nut Screw for Disconnect Rod
			Gear Z12		1	M0679797	O ring RC 2025 series
	2	S414900080	Bushing Ø12xØ14x8	28	1	A96572300	Performa W46 Drum
15	1	A94132200	Assy Housing Winch 46				Performa Drum W46
			Housing Winch 46		61	M0619580	Ball 3/16"
	1	S414900080	Bushing Ø12xØ14x8		1	S6572900A3	Bearing ring W46
	1	S413330085	Bushing Ø12xØ14x11				Winch Product Sticker**
	1	S4133200B3	Bushing for support	29	1	S657300052	Performa Shim W46
16	5	M0606303	Screw M8x25 UNI 5931	30	1	S416110002	Disconnect Rod W46
17	2	A74133700	Bearing Ø75xØ87x26				

*Available with service kit; see website www.harken.com

**Winch product sticker



Performa Winch 46.2 STQP EL/HY

Pos	Q.ty	Code	Description	Pos	Q.ty	Code	Description
1	1	A94163700	Assy base W46Q for thrust bearing <i>Ring base W46 STQ</i> <i>Assy Base Winch 46 EL/HY</i> <i>Base W46</i>	18	1	S413390080	Spacer
	1	S413350080	<i>Roller Ø6x19</i>	19	1	A94161000	Assy Central Shaft W46 EL/HY <i>Central Shaft W46 EL/HY</i> <i>Washer Ø17.2xØ32x1.5</i>
	1	S4130900A7	<i>Bushing Ø22xØ25x8.5</i>		1	S413880002	
	1	S414890080	<i>Bushing Ø9xØ11x7</i>	20			Winch Serial Number Sticker
	1	S413330085	<i>Bushing Ø12xØ14x11</i>	21	1	S4129400A0	Stripper arm support
2	1	S413020004	Gear Z12	22	1	A96589500	Performa Assy Jaws W46 <i>Lower Jaw W46</i> <i>Performa Upper jaw W46</i> <i>Peeler W46 - 50</i> <i>Spring</i>
3	1	S413300004	Pin Ø12x60	1	1	S414280080	
4	1	S278170002	Washer Ø12.5xØ48x1.5	4	4	S385970001	
5	1	S413260004	Gear Z27	23	4	M0601803	Screw UNI EN ISO 1207 - M6x35 - A4
6	1	S414260004	Pawls Carrier Ø8xN2	24	1	S657390019	Performa Black Stripper Arm W46
7	6	S000090004	Racing pawl Ø8*	25	3	M6007103	Screw M6x50 UNI6107
8	6	S000380001	Pawl Spring Ø8*	26	1	S4127000A5	Cover 2 speed W46
9	1	S412830041	Gear Z23	27	1	A94149300	Assembly Socket W35-80 EL/HY <i>Socket Handle W20/80</i> <i>Washer Ø25xØ15x4</i> <i>Nut Screw for Disconnect Rod</i> <i>O ring RC 2025 series</i>
10	1	S413250041	Pinion Z13	1	1	S414940085	
11	2	M6017694	Bushing PSM-1214-20	1	1	S414930003	
12	1	S413120002	Washer Ø22.5xØ45x1	1	1	M0679797	
13	1	S413070004	Pin Ø9xØ12x32.5	28	1	A94163501	Performa Drum W46 Q <i>Performa Drum W46 Q</i> <i>Ball 5/16"</i> <i>Winch STQ product sticker**</i>
14	1	A94133400	Assy Gear Z12 <i>Gear Z12</i> <i>Bushing Ø12xØ14x8</i>	72	1	M0610280	
	2	S414900080		1	1	S498590063	
15	1	A94132200	Assy Housing Winch 46 <i>Housing Winch 46</i> <i>Bushing Ø12xØ14x8</i> <i>Bushing Ø12xØ14x11</i> <i>Bushing for support</i>	29	1	S416110002	Disconnect Rod W46
	1	S414900080					
	1	S413330085					
	1	S4133200B3					
16	5	M0606303	Screw M8x25 UNI 5931				
17	2	A74133700	Bearing Ø75xØ87x26				

*Available with service kit; see website www.harken.com

**Winch product sticker



Horizontal electric motor

TOP VIEW

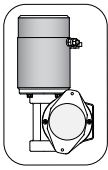

* **Motor installed in right-hand configuration.**

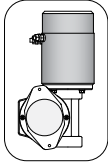

** **Motor installed in left-hand configuration.**

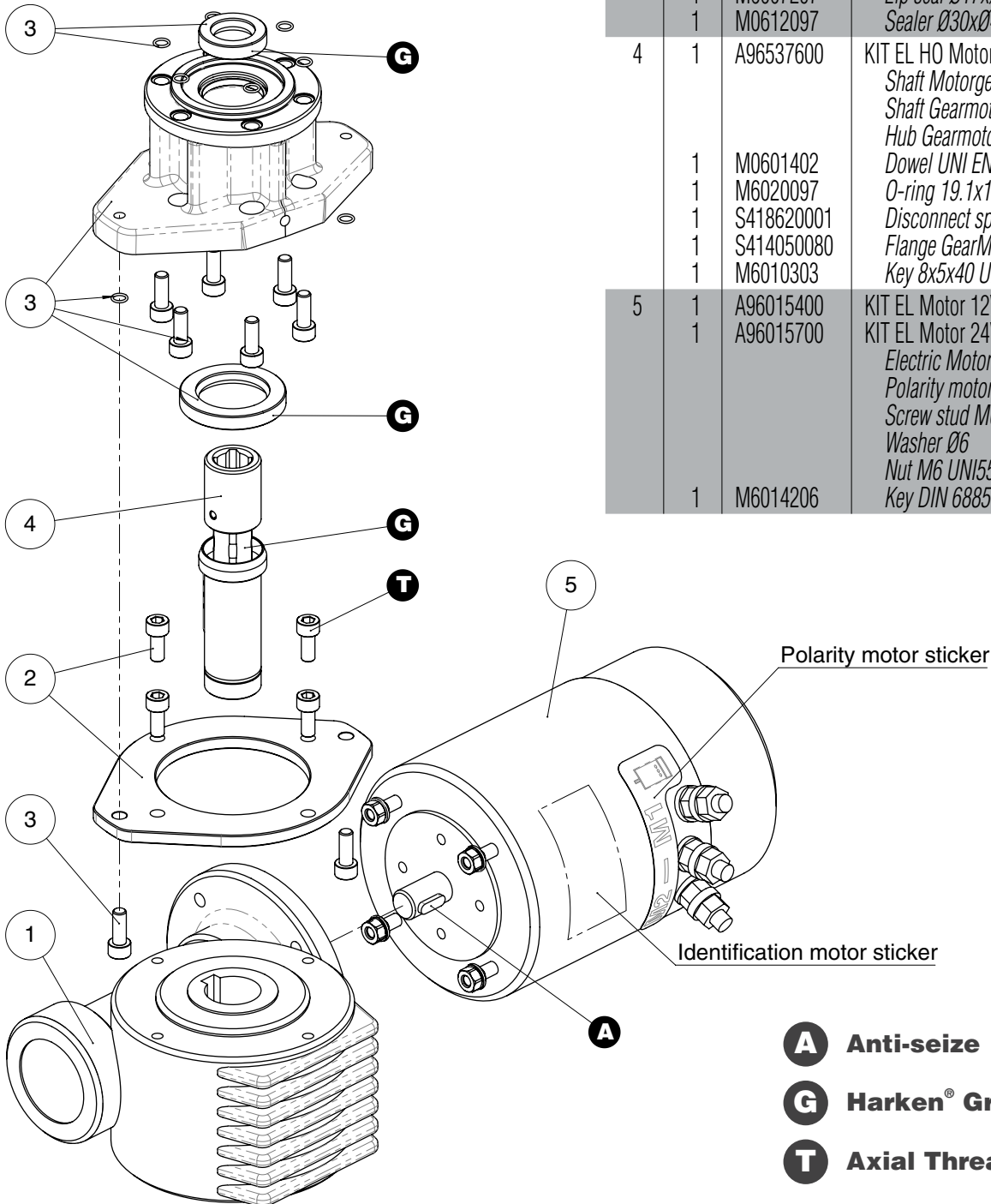

Pos	Q.ty	Code	Description
1	1	A93127900	KIT Gear Reduction 1/24
	1	A94194900	KIT LM Gear Reduction 1/24
2	1	A94149200	KIT Assy Electric Motor Flange
	1	A94149200L	KIT Assy Electric Motor Flange Left
	4	M0606803	Electric Motor Flange Screw M6x14 UNI 5931
	3	A94149500	KIT EL HO Motor Flange
3	1	A94149500	Horizontal Motorgear Flange
	8	S415360003	Screw M6x16 UNI EN ISO 5931:2003 precote coating
	8	M601560097	O-Ring Seal ORM 0055-10 (Ø5,5 x Ø1)
	1	M6007297	Lip seal Ø17xØ30x7
	1	M0612097	Sealer Ø30xØ47x7
4	1	A96537600	KIT EL HO Motor Clutch
			Shaft Motorgear HO
			Shaft Gearmotor HO
			Hub Gearmotor
	1	M0601402	Dowel UNI EN ISO 8752:2000- Ø4x24
	1	M6020097	O-ring 19.1x1.6
	1	S418620001	Disconnect spring
	1	S414050080	Flange GearMotor Shaft HO
1	M6010303	Key 8x5x40 UNI 7511	
5	1	A96015400	KIT EL Motor 12V 0,7kW
	1	A96015700	KIT EL Motor 24V 0,9kW
			Electric Motor
			Polarity motor sticker
			Screw stud M6x26
			Washer Ø6
1	M6014206	Nut M6 UNI5588	
		Key DIN 6885 5x5x15	

- A** Anti-seize
- G** Harken® Grease
- T** Axial Threadlocker

Vertical electric motor

Pos	Q.ty	Code	Description	Pos	Q.ty	Code	Description
1	1	A96010500	KIT EL Motor 12V 1,5kW VT	3	1	A94150500	KIT EL VT Motor Flange Vertical Motorgear Flange
	1	A96010400	KIT EL Motor 24V 2kW VT Electric Motor		4	M0602903	NUT M8 - UNI 5588 - A4
			Polarity motor sticker		4	M0603103	WASHER 8.4 U1751 DIN127 A4
			Screw M8x20 UNI5931		1	M6007297	Lip seal Ø17xØ30x7
	1	M6014206	Key DIN 6885 5x5x15	6	M6015697	O-Ring Seal ORM 0055-10 (Ø5,5 x Ø1)	
2	1	A96562900	Vertical reduction gear box 1/21.3	6	S415360003	Screw M6x16 UNI EN ISO 5931:2003 precote coating	
				4	M0606303	Screw M8x25 UNI 5931	
				4	1	A94193700	KIT EL VT Motor Clutch Connecting Coupling Ø31.5 Toothed coupling
				1	M0620401	Spring pin 5x40 DIN1481	
				1	S326490001	Spring	
				1	S415040080	Bushing	
				1	S329360082	Washer	
				1	M0666603	Screw M6x16 UNI 5933	

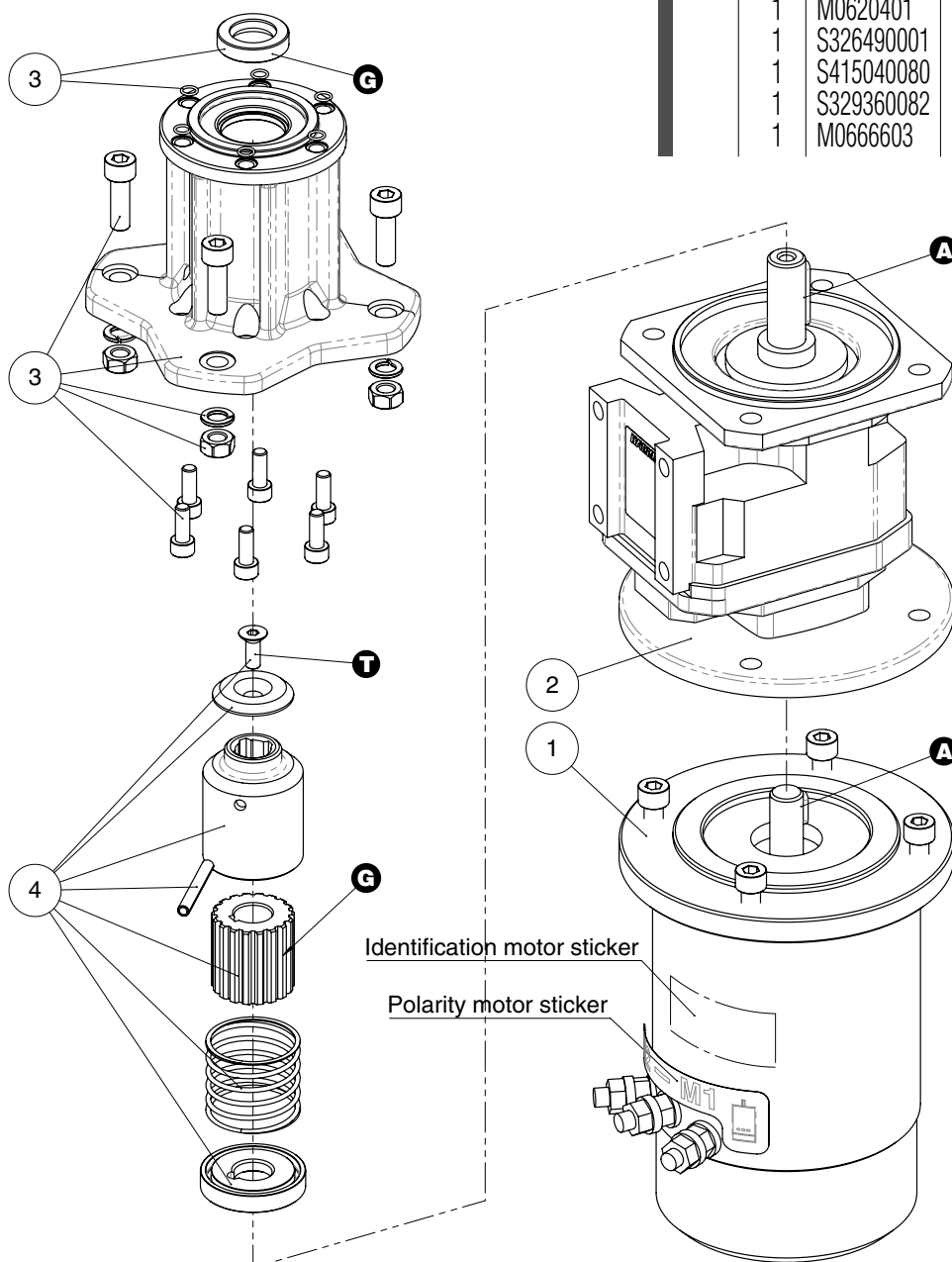

- A** Anti-seize
- G** Harken® Grease
- T** Axial Threadlocker

Hydraulic motor

Pos	Q.ty	Code	Description	Pos	Q.ty	Code	Description
1	1	G045942000Y	Hydraulic motor W46-60	4	1	A94149100	KIT HY Motor Flange W46-70
2	1	S415000080	Hydraulic Motor Spacer	6	1	S415360003	Hydraulic Motorgear Flange Screw M6x16 UNI EN ISO 5931:2003 precote coating
3	1	A94193200	KIT Clutch HY Motor W46-70	6	1	M6015697	O-Ring Seal ORM 0055-10 (Ø5,5 x Ø1)
			Toothed coupling	1	1	M6007297	Lip seal Ø17xØ30x7
			Connecting Coupling Ø31.5	2	1	M0621503	Washer D.13 U1751 DIN127
	1	M0620401	Spring pin 5x40 DIN1481	2	1	M0667103	Screw M12x35 UNI5931
	1	S415010080	Bushing				
	1	S326490001	Spring				
	1	S329360082	Washer				
	1	M0635303	Screw M8x16 UNI6109				

