

Installation and Maintenance Manual

MRRW-E

Radial[®] Electric Winch **46 Rewind[™]**

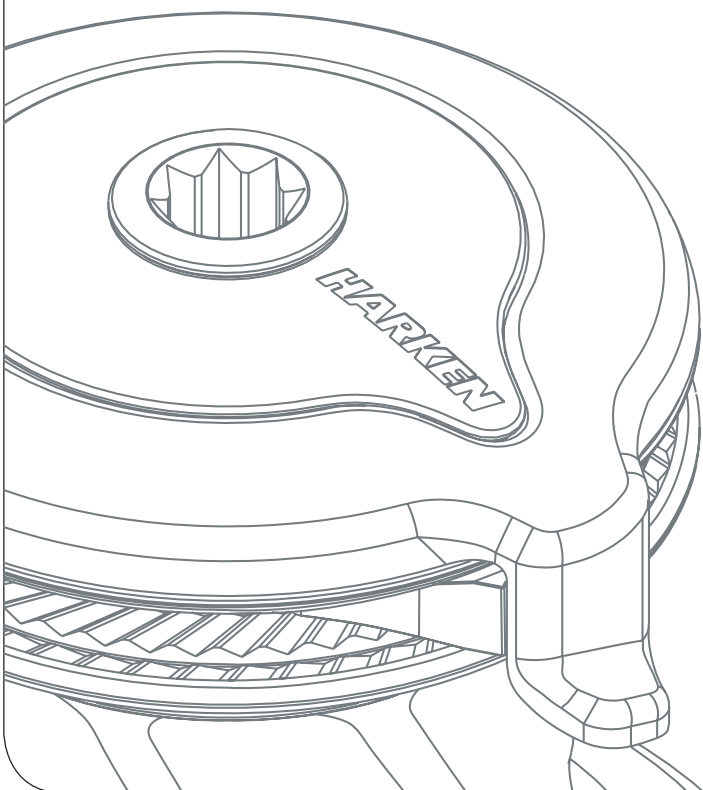

HARKEN[®]

Introduction	3
Technical characteristics	3
<i>Performance data</i>	3
<i>Weight</i>	3
<i>Maximum working load</i>	4
Outline	4
<i>Radial® 46 Rewind™</i>	4
<i>Horizontal electric motor</i>	4
Installation	5
<i>Procedure 1</i>	7
<i>Procedure 2</i>	8
<i>Winch installation procedure</i>	10
<i>Winch drilling cut-out</i>	10
<i>Positioning the self-tailing arm</i>	10
Motor installation procedure	11
<i>Electric equipment</i>	11
Maintenance	14
<i>Washing</i>	14
<i>Maintenance table</i>	14
<i>Disassembly procedure</i>	14
<i>Exploded view with maintenance products</i>	17
<i>Assembly</i>	18
Harken® limited worldwide warranty	19
Ordering spare parts	19
Exploded view	20
Parts List	22
<i>Winch 46 Rewind™ STA EL</i>	22
<i>Winch 46 Rewind™ STC EL</i>	23
<i>Winch 46 Rewind™ STCW EL</i>	24
<i>Winch 46 Rewind™ STBBB EL</i>	25
<i>Winch 46 Rewind™ STCCC EL</i>	26
<i>Horizontal electric motor 12V/24V</i>	27
<i>Horizontal electric motor 24V H82</i>	28

Introduction

This manual gives technical information on winch installation and maintenance, including disassembling and reassembling.

This information is DESTINED EXCLUSIVELY for specialised personnel or expert users.

Installation, disassembling and reassembling of the winch by personnel who are not experts may cause serious damage to users and those in the vicinity of the winch.

Harken® accepts no responsibility for defective installation or reassembly of its winches.

In case of doubt the Harken® Tech Service is at your disposal at techservice@harken.it

This Manual is available only in English. If you do not fully understand the English language, do not carry out the operations described in this Manual.

NOTICE

To use and understand this manual, user must refer to other documents, available on web site www.harken.com and listed below:

- The Dual Function Control Box user manual, for the use of the Dual Function Control Box.
- The Dual Function Control Box installation manual, for all details, informations, wiring schemes and warnings about its installation

Technical characteristics

	Power ratio	Gear ratio
1st speed	11,70 : 1	2,30 : 1
2nd speed	46,50 : 1	9,17 : 1

The theoretical power ratio does not take friction into account.

Performance data

46 Rewind™ Winch

	horizontal motor		horizontal motor	
	12 V (700 W)		24 V (700 W)	
	1st speed	2nd speed	1st speed	2nd speed
line speed (m/min)**	25,5	6,5	25,5	6,5
max load (Kg)	315	1300	315	1300

***Line speed is measured with no load*

		motor nominal power (W)		current absorption at winch MWL (A)	
		12 V	24 V	12 V	24 V
		46 Rewind™ Winch	horizontal	700	700

Weight

	ST A	ST C/CW	ST BBB/CCC
weight (Kg)	16	19	19,7

Versions:

A = drum in anodised aluminium

C = drum in chrome bronze

CW = chrome/white

BBB = all bronze

CCC = All-Chrome bronze

Maximum working load

WARNING!

The maximum working load (MWL) for the 46 Rewind™ Winch is 1300 Kg (2866 lb).

Subjecting the winch to loads above the maximum working load can cause the winch to fail or pull off the deck suddenly and unexpectedly during high loads causing severe injury or death.

Outline

46 Rewind™ Winch

E [mm]	41*
	67*

*For different lengths refer to pages 27-28

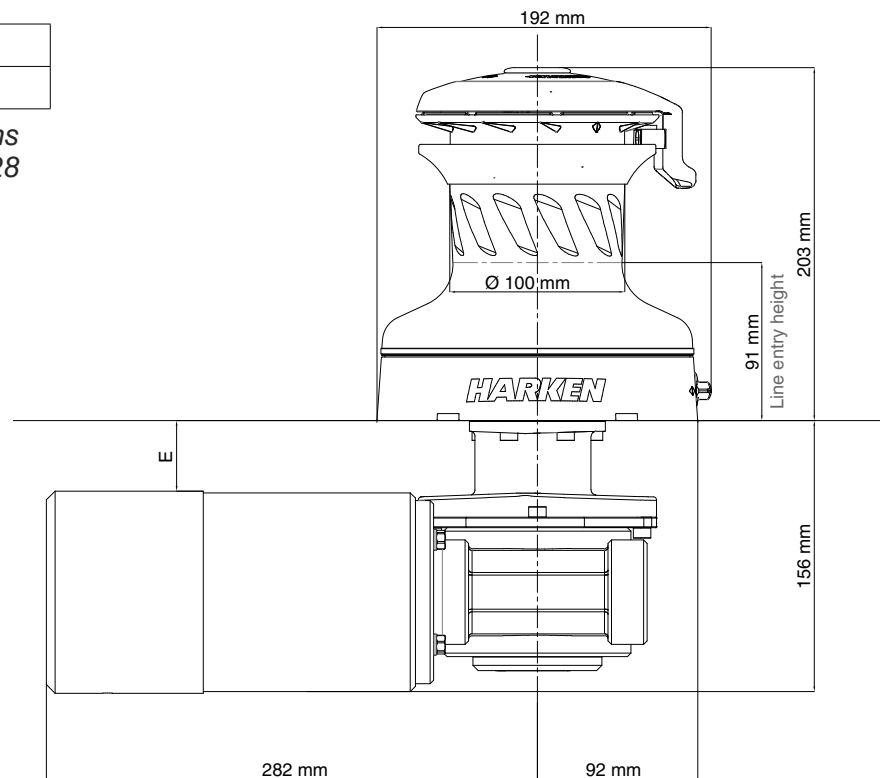

Installation

The winch must be installed on a flat area of the deck, reinforced if necessary to bear a load equal to at least twice the maximum working load of the winch.

It is the installer's responsibility to carry out all structural tests needed to ensure that the deck can bear the load.

Harken® does not supply the screws needed to install the winch since these may vary depending on the deck on which it is to be installed.

It is the installer's responsibility to choose the correct screws taking account of the loads they will have to bear.

Harken® assumes no responsibility for incorrect installation of its winches or for an incorrect choice of mounting screws.



DANGER!

Incorrect installation of the winch may cause severe injury or death. Consult the yard that built the boat in the case of doubt over the correct positioning of the winch.



WARNING!

Failure to use the correct number and type of mounting fasteners or failure to ensure the correct deck strength can result in the winch pulling off the deck suddenly and unexpectedly during high loads causing severe injury or death.



WARNING!

Verify the entry angle of the sheet. This must be 8° with tolerance of ±2°, to avoid sheet overrides and damaging the winch or making the winch inoperable leading to loss of control of the boat which can lead to severe injury or death.



WARNING!

Mount the winch on the deck so that the final drive gear is positioned where the sheet enters the winch drum. Incorrect position of drive gear can weaken winch leading to failure which can cause an accident leading to severe injury or death.

NOTICE

For winch STA, STC and STCW versions only you can find the icon ▲ on the skirt to identify the drive gear position.

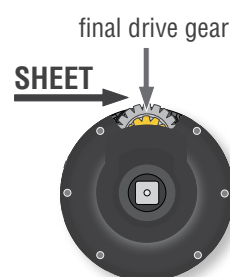
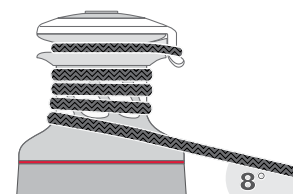

After correctly positioning the final drive gear with respect to the load, check that the motor, gearing, electrical wiring and/or hydraulic pipes can be housed below decks. To help find the optimal compromise, remember that, to make the installation of the motor easier, it can be coupled to the winch in different positions.

Once you have decided the correct mounting position for the winch on the deck and checked the space available below deck, proceed with the installation.

The winch can be installed following one of the two procedures below (**Procedure 1** or **Procedure 2**).

Before starting the Installation procedure, set the knob in the following position:

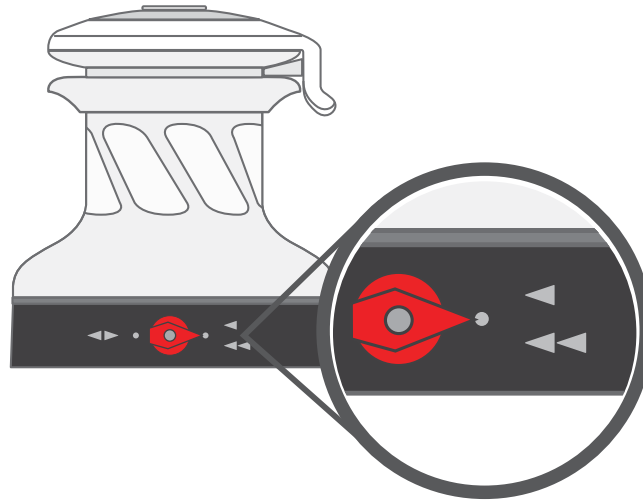

Procedure 1

To install the winch, remove the drum and use bolts as described ahead.

Tools needed

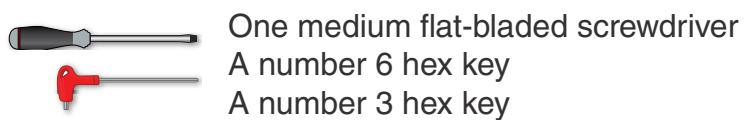

To identify the various parts, refer to the exploded view at the end of this Manual.

 Torque to apply when assembling



1. Pull out the disconnect rod n°28



2. Unscrew the central screw ($\approx 2\text{Nm}/18\text{ in-lb}$)



3. Slide off the assy socket n°37 and the cover n°38.
Pay attention to the o-ring in the socket.



4. Unscrew the three screws n°19
($\approx 4\text{Nm}/35\text{ in-lb}$)



5. Remove the stripper arm n°40 by rotating and lifting it.



6. Lift off the drum n°33

Winch STA, STC and STCW versions:

Install the winch on the deck in the position you have chosen, keeping in mind the limits described on page 4 and using socket head (SH) bolts.

Winch STBBB and STCCC versions:

Install the winch on the deck in the position you have chosen, keeping in mind the limits described on page 4 and using socket head (SH) bolts or hexagonal headed bolts (HH).

Procedure 2

To install the winch, remove the winch skirt and use hexagonal headed (HH) bolts.

Tools needed

A number 3 hex key

One medium flat-bladed screwdriver



1. Unscrew the screw n°36 and slide off the knob (0,5 Nm/ 4,42 in-lb)



2. Remove the skirt n°2 with the help of the screwdriver placed as shown by the symbol 



3. Position the 5 M8 hexagonal headed bolts in their holes



4. Reposition the skirt n°2 in its housing



5. Press down the skirt to position it correctly

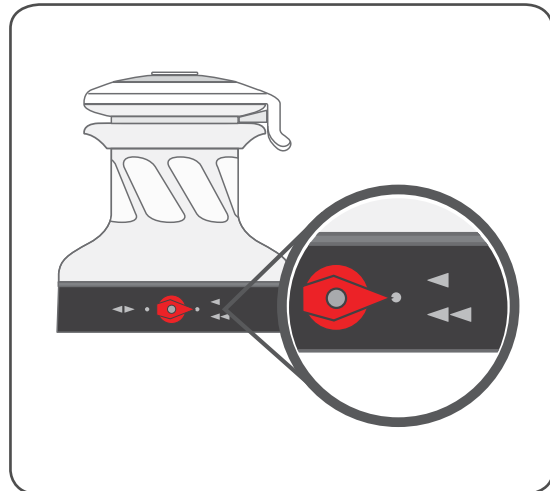

6. Reposition the knob in the Rewind position (see figure)

To identify the various parts, refer to the exploded view at the end of this Manual.

NOTICE

Make sure the skirt is correctly clipped on to the base of the winch.

Install the winch on the deck in the position you have chosen, keeping in mind the limits described on page 4 and using hexagonal headed bolts.

Winch installation procedure

Carry out **Procedure 1** or **Procedure 2**, then install the winch on the deck in the chosen position.

NOTICE

Before drilling the deck, check the space available below deck for the flange and the motor

- A.** Position the base of the winch on the deck and mark the position of the holes or use the drilling cut-out template at the point where you have decided to place the winch.

Below is a reduced scale diagram.

The drilling cut out template is available on the Harken® website, www.harken.com

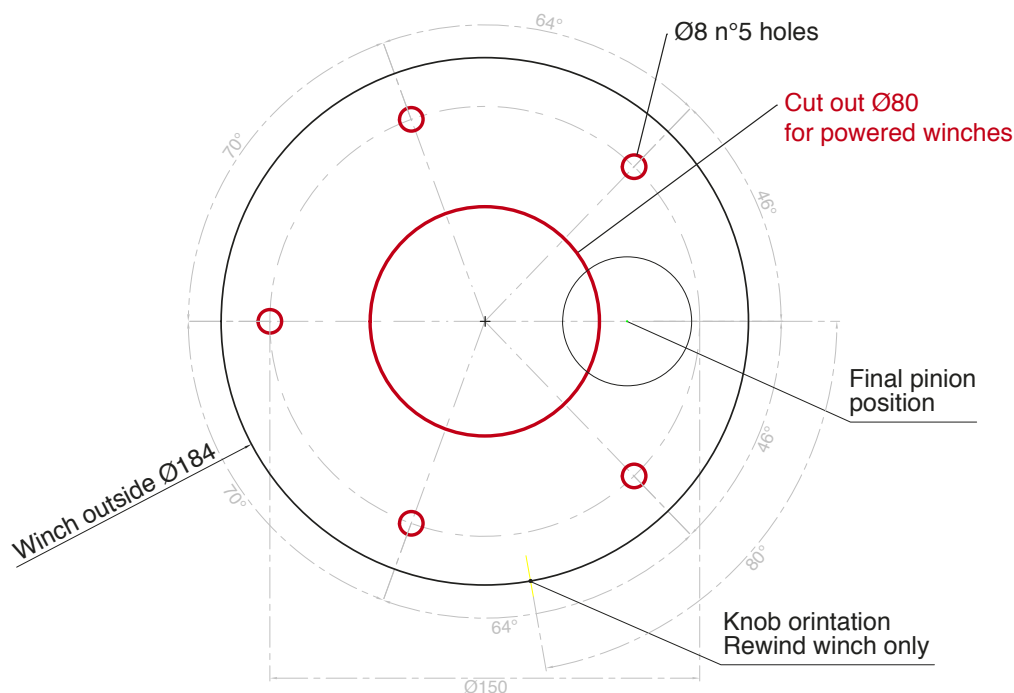

- B.** Remove the winch and drill the five 8.5 mm diameter holes.
C. Bolt the base of the winch to the deck using five M8 bolts (not supplied by Harken®) as described at Procedure 1 or Procedure 2, correctly chosen for the thickness and type of the boat deck. Consult the yard that built the boat in case of doubt.



WARNING!

To install the winch on the deck, use only bolts in A4 stainless steel (DIN 267 part11). Bolts made of other materials may not have sufficient strength or may corrode which can result in winch pulling off deck suddenly and unexpectedly during high loads causing severe injury or death.

NOTICE

To mount winches on the deck, do not use countersunk bolts.

- D.** Fill the mounting holes with a suitable marine sealant.
E. Remove the excess adhesive/sealant from the holes and base drainage channels
F. Reassemble the winch following the steps in **Procedure 1** or **Procedure 2** in the reverse order, and apply the products indicated in the section on maintenance.

Positioning the self-tailing arm

Position the self-tailing arm so that the line leaving the winch is led into the cockpit.

Motor installation procedure



WARNING!

Make sure that the power is switched off before installing or carrying out maintenance on the winch.

Once you have installed the winch on the deck, proceed with motor installation. The motor can be coupled to the winch in different positions. Check the space available below deck and choose the suitable position.

Tools needed

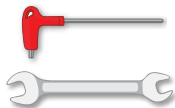

A number five hex key

Two number thirteen wrenches



1. Position the flange (see Page 12)



2. Tighten six M6 precote coated screws (8 Nm/ 71 in-lb)



3. Position the reduction gear and motor



4. Tighten the two screws (8 Nm/ 71in-lb). Be sure to align the flange.

NOTICE

Before positioning the flange, check to make sure that seal is seated correctly.



After winch is assembled and before sailing, test the powered winch functioning.

Electric equipment

To guarantee greater efficiency in terms of safety and long life, for every winch model is mandatory to install the Dual Function Control Box.

To fasten the Dual Function Control Box containing solenoids to bulkhead or wall, for all installation details and for all electric wiring schemes, refer to the Dual Function Control Box manual.



WARNING!

Before installing and using the device, read carefully the Dual Function Control Box manual available on web site www.harken.com

Refer to the following chart for wire size:

Total distance between winch and battery

Winch size	Current voltage	Under 16.4 ft AWG	Under 5 m mm ²	16.4 - 32.8 ft AWG	5 m - 10 m mm ²	32.8 - 49.2 ft AWG	10 m - 15 m mm ²	49.2 - 65.6 ft AGW	15m - 20 m mm ²
46 Rewind™	12 V	2	32	0	50	00	70	000	95
46 Rewind™	24 V	5	16	3	25	2	35	0	50

Refer to the following chart for HCP model:

Winch size	Current voltage	HCP model	Ampere rating
46 Rewind™	12 V	HCP1717	80A
46 Rewind™	24 V	HCP1717	80A

NOTICE

To connect motor, attach cable terminals to clamps between nut and lock nut. Hold nut in contact with motor using a spanner and tighten other nut with second spanner. Take special care not to turn the central spindles. These instructions apply when assembling and disassembling. We recommend using a torque wrench so as to obtain a torque equal to and no greater than 10 Nm (88 in-lb).

**NOTICE**

Note that correct electrical contact sequence is:
Nut – Cable Terminal – Self-Locking Washer – Lock Nut



Maintenance

Washing

Winches must be washed frequently with fresh water, and in any case after each use. Do not allow teak cleaning products or other cleaners containing caustic solutions to come into contact with winches and especially anodised, chrome plated or plastic parts. Do not use solvents, polishes or abrasive pastes on the logos or stickers on the winches. Make sure that the holes and drainage channels in the base of the winch are not obstructed so that water does not collect.

Maintenance table

Winches must be visually inspected at the beginning and end of every season of sailing or racing. In addition they must be completely overhauled, cleaned and lubricated at least every 12 months. After an inspection, replace worn or damaged components. Do not replace or modify any part of the winch with a part that is not original.



WARNING!

Periodic maintenance must be carried out regularly. Lack of adequate maintenance shortens the life of the winch, can cause serious injury and also invalidate the winch warranty. Installation and maintenance of winches must be carried out exclusively by specialized personnel.

In the case of doubt contact Harken® Tech Service at techservice@harken.it







WARNING!

Make sure that the power is switched off before installing or carrying out maintenance on the winch.

Winch disassembly procedure

Tools needed

-  *One medium flat-bladed screwdriver*
-  *A number five hex key*
-  *Brush*
-  *Rags*

To identify the various parts refer to the exploded view at the end of this Manual.

 Torque to be applied in assembly phase

Carry out **Procedure 1** as shown in the paragraph on winch installation and then do the following:



7. Unscrew the 5 hex screws n°12
($\approx 20\text{Nm}/177\text{ in-lb}$)



8. Remove the assy housing n°11



9. Slide out the gear n°10



10. Remove gear n°27.
Pay attention to the springs.



11. Unscrew the screw n°30 and slide out the main shaft n°21



12. Slide out the command group and pay attention to the two balls n°23



13. Remove the pinion n°7



14. Remove the gear n°20

If it is necessary to replace any **jaws** of the winch, proceed as follows:



I. Unscrew the 4 screws n°18
(\approx 4Nm/35 in-lb)



II. Remove the jaws n°39

Once the winch is completely disassembled, clean the parts with a degreasing that does not leave residues, proper to clean metal components; rinse plastic parts in fresh water. Once you have done this, dry the parts with cloths that do not leave residue.

Inspect gears, bearings, pins and pawls for any signs of wear or corrosion.

Carefully check the teeth of gears and ring gears to make sure there are no traces of wear.

Check the roller bearings and check there are no breaks in the bearing cages.

Replace worn or damaged components.

Carry out maintenance on components using the products listed below.

For more information on which products to use where, refer to the exploded diagram below.

Use a brush to lightly lubricate all gears, gear pins, teeth and all moving parts with grease.

Lightly lubricate the pawls and springs with oil. Do not use grease on the pawls!

Winch exploded view with maintenance products

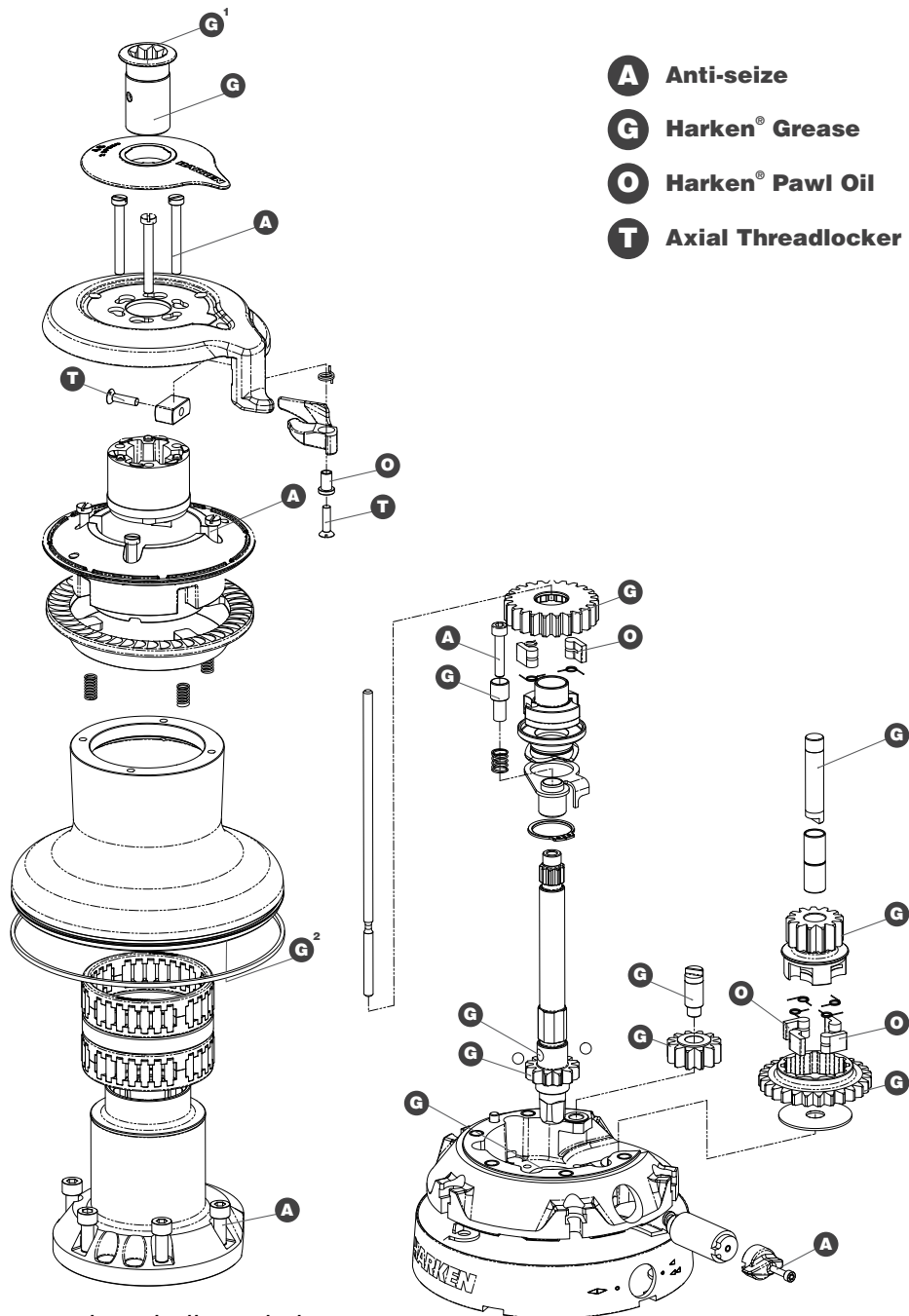

Apply Harken® grease where indicated above
 Apply Harken® grease: 1. on assy socket screw - 2. on drum gear

NOTICE

On every gear and every component that must be greased, apply Harken® grease with a brush in a proper quantity as shown below:



NOTICE

Harken® grease to apply on all teeth: do not use excessive quantity of product to void wastes. If in contact with the pawls, an excess of grease can compromise the safety of the winch.

Winch assembly

Make sure that the holes and drainage channels in the base of the winch are not obstructed
 Assemble the winch in the reverse order of the sequence in the section on disassembly.

To tighten bolts, use the torque indicated in the disassembly procedure.

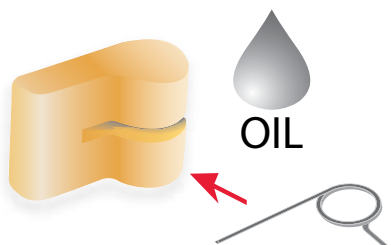

To assemble the pawls:

correctly position the spring in its housing as shown at left. Hold the spring closed and slide the pawl into its housing. Once in position, check that the pawls can be easily opened and closed with a finger.

NOTICE! Before closing the winch, make sure the holes and drainage channels in the base of the winch are not obstructed.

NOTICE! Before screw the central screw, check the correct position of the o-ring in the assy socket and apply Harken® grease.

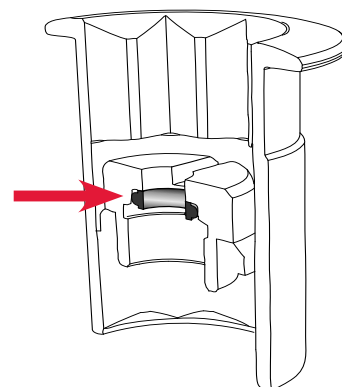

NOTICE! Insert the disconnect rod in the winch, with the groove in the lower part of the rod.

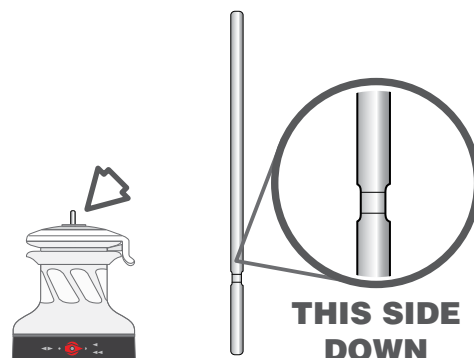

In case of doubt concerning the assembly procedure contact Harken® Tech Service: techservice@harken.it

Harken® limited worldwide warranty

Refer to the Harken® Limited Worldwide Warranty in the Harken® Catalogue and on the website www.harken.com

Ordering spare parts

Spare parts can be requested from Harken® as described in the Harken® Limited Worldwide Warranty, indicating the part number in the Parts List and including the serial number of the winch for which the parts are required.

The serial number of the winch is printed on a plate on the drum support of the winch.



Manufacturer

Harken® Italy S.p.A.

Via Marco Biagi, 14
22070 Limido Comasco (CO) Italy
Tel: (+39) 031.3523511
Fax: (+39) 031.3520031
Email: info@harken.it
Web: www.harken.com

- **Tech Service**
Email: techservice@harken.it
- **Customer Service**
Tel: (+39) 031.3523511
Email: info@harken.it

Headquarters

Harken®, Inc.

1251 East Wisconsin Avenue
Pewaukee, Wisconsin 53072-3755 USA
Tel: (262) 691.3320
Fax: (262) 691.3008
Email: harken@harken.com
Web: www.harken.com

- **Tech Service**
Email: technicalservice@harken.com
- **Customer Service**
Tel: (262) 691-3320
Email: customerservice@harken.com

Exploded view

Winch 46 Rewind STA, STC, STCW, STBBB, STCCC EL

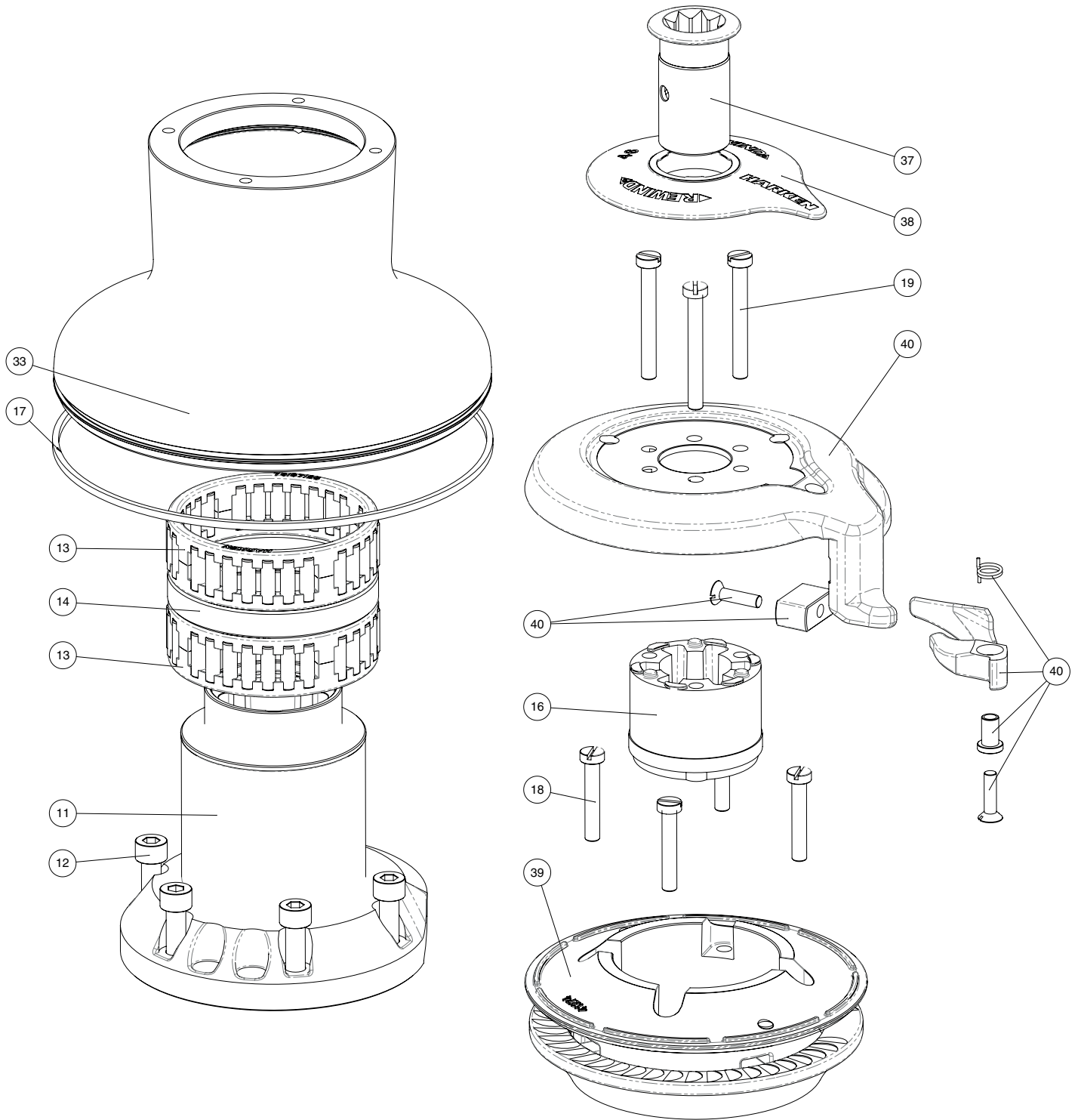

Winch 46 Rewind STA, STC, STCW, STBBB, STCCC EL

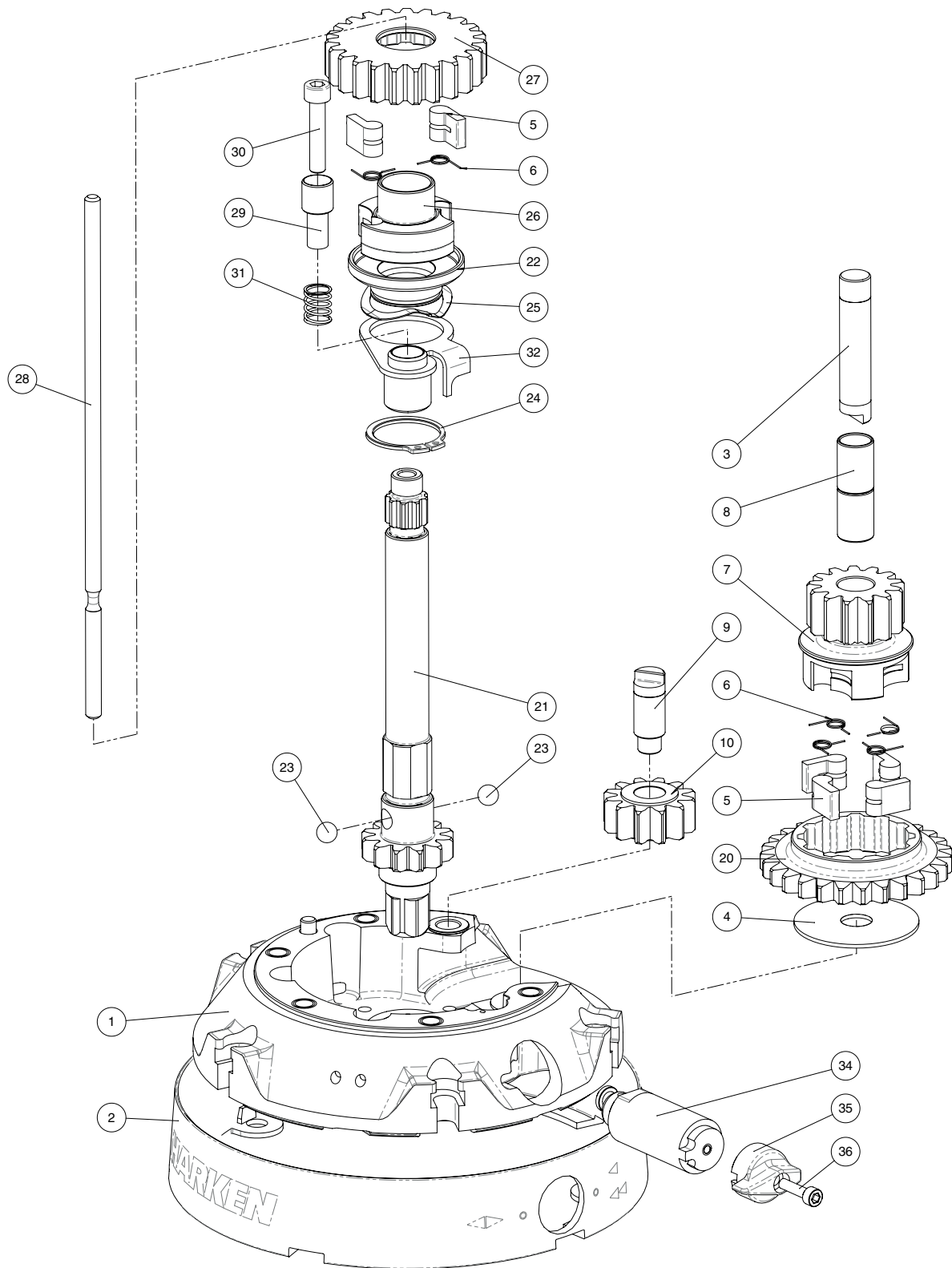

Parts List

Winch 46 Rewind™ STA EL

A = drum in anodised aluminium

Pos.	Q.ty	Code	Description	Pos.	Q.ty	Code	Description
1	1	A94164101	W46 RW Base Assembly	23	2	M0614103	Ball 5-16" inox
	1	S413350080	W46 RW Base	24	1	M0616603	Retaining ring UNI 7435 - Ø28
	1	S414890080	Roller Ø6x19	25	1	M0630802	Elastic ring SSR0137-S17
	1	S413330085	Bushing Ø9xØ11x7	26	1	S416250004	Pawls carrier Ø8xN2
	1	S4130900A7	Bushing Ø12xØ14x11	27	1	S416240041	Gear Z23
	1	M6009463	Bushing Ø22xØ25x8.5	28	1	S416300002	Disconnect rod 46 Rewind
	1	M6009463	Spring loaded ball plunger Ø6	29	1	S416530004	Pin for switch
2	1	A94164200	Assy Skirt Winch 46 Rewind	30	1	M0624203	Screw M6x30
			Skirt W46 Rewind	31	1	S418590001	Spring Ø10.67x12.7
			Winch Product Sticker**	32	1	A74165000	Command x W46 Rewind
3	1	S413300004	Pin Ø12x60	33	1	S416480053	Drum W46 Rewind
4	1	S278170002	Washer Ø12.5xØ48x1.5	34	1	A94191800	Assy knob W46 Rewind
5	6	S000080003	Pawl Ø8*				Knob W46 Rewind
6	6	S000380001	Pawl Spring Ø8*				Heli-coil M4x8
7	1	S413250041	Pinion Z13		1	S419190004	Pin for knob
8	2	M6017694	Bushing PSM-1214-20		1	S419200041	Bushing Ø6.5xØ4x3
9	1	S413070004	Pin Ø9xØ12x32.5	35	1	S497400180	Knob Rewind
10	1	A94133400	Assy Gear Z12	36	1	M0624103	Screw M4x16 UNI5931
	2	S414900080	Gear Z12	37	1	A94165200	Assy socket Rewind
			Bushing Ø12xØ14x8				Socket Handle
11	1	A96756700	W46 RW Housing Assembly		1	S414940085	Washer Ø25xØ15x4
	1	S414900080	W46 RW Housing		1	S414930003	Nut Screw for Disconnect Rod
	1	S413330085	Bushing Ø12xØ14x8		1	M0679797	O ring RC 2025 series
	1	S4133200B3	Bushing Ø12xØ14x11	38	1	S6511900A5	Cover W46 rewind
	1	S4133200B3	Bushing for support	39	1	A94192100	Assy jaws Winch 46 Rewind
12	5	M0606303	Screw M8x25 UNI 5931				Lower Jaw W46 Rewind
13	2	A74133700	Bearing Ø75xØ87x26		4	S385970001	Upper Jaw W46
14	1	S413390080	Spacer				SPRING
15			Winch Serial Number Sticker	40	1	A74165500	Stripper arm Winch 46 Rewind C
16	1	S4129400A0	Stripper arm support				Stripper arm W46 Rewind C
17	1	S281690097	Red line		1	S4165600F0	Peeler W46 Rewind C
18	4	M0601803	Screw UNI EN ISO 1207 - M6x35 - A4		1	S416570001	Spring stripper arm W46 Rewind
19	3	M6007103	Screw M6x50 UNI6107		1	S416580041	Bushing
20	1	S416540004	Gear Z27		1	S419170080	Slider
21	1	S416280004	Main shaft W46 Rewind		2	M0619003	Screw M5x20 UNI 6109
22	1	S416260041	Disconnect flange				

*Available with service kit; see website www.harken.com

**Winch product sticker



Winch 46 Rewind™ STC EL
C = drum in chrome bronze

Pos.	Q.ty	Code	Description	Pos.	Q.ty	Code	Description
1	1	A94164101	W46 RW Base Assembly <i>W46 RW Base</i>	24	1	M0616603	Retaining ring UNI 7435 - Ø28
	1	S413350080	<i>Roller Ø6x19</i>	25	1	M0630802	Elastic ring SSR0137-S17
	1	S414890080	<i>Bushing Ø9xØ11x7</i>	26	1	S416250004	Pawls carrier Ø8xN2
	1	S413330085	<i>Bushing Ø12xØ14x11</i>	27	1	S416240041	Gear Z23
	1	S4130900A7	<i>Bushing Ø22xØ25x8.5</i>	28	1	S416300002	Disconnect rod 46 Rewind
	1	M6009463	<i>Spring loaded ball plunger Ø6</i>	29	1	S416530004	Pin for switch
2	1	A94164200	Assy Skirt Winch 46 Rewind <i>Skirt W46 Rewind</i> <i>Winch Product Sticker**</i>	30	1	M0624203	Screw M6x30
3	1	S413300004	Pin Ø12x60	31	1	S418590001	Spring Ø10.67x12.7
4	1	S278170002	Washer Ø12.5xØ48x1.5	32	1	A74165000	Command x W46 Rewind
5	6	S000080003	Pawl Ø8*	33	1	S653520043	Drum 46 C rewind
6	6	S000380001	Pawl Spring Ø8*	34	1	A94191800	Assy knob W46 Rewind <i>Knob W46 Rewind</i> <i>Heli-coil M4x8</i> <i>Pin for knob</i> <i>Bushing Ø6.5xØ4x3</i>
7	1	S413250041	Pinion Z13		1	S419190004	
8	2	M6017694	Bushing PSM-1214-20		1	S419200041	
9	1	S413070004	Pin Ø9xØ12x32.5	35	1	S497400180	Knob Rewind
10	1	A94133400	Assy Gear Z12 <i>Gear Z12</i> <i>Bushing Ø12xØ14x8</i>	36	1	M0624103	Screw M4x16 UNI5931
	2	S414900080		37	1	A94165200	Assy socket Rewind <i>Socket Handle</i> <i>Washer Ø25xØ15x4</i> <i>Nut Screw for Disconnect Rod</i> <i>O ring RC 2025 series</i>
11	1	A96756700	W46 RW Housing Assembly <i>W46 RW Housing</i> <i>Bushing Ø12xØ14x8</i> <i>Bushing Ø12xØ14x11</i> <i>Bushing for support</i>		1	S414940085	
	1	S414900080			1	S414930003	
	1	S413330085			1	M0679797	
	1	S4133200B3		38	1	S6511900A5	Cover W46 rewind
12	5	M0606303	Screw M8x25 UNI 5931	39	1	A94192100	Assy jaws Winch 46 Rewind <i>Lower Jaw W46 Rewind</i> <i>Upper Jaw W46</i> <i>SPRING</i>
13	2	A74133700	Bearing Ø75xØ87x26		4	S385970001	
14	1	S413390080	Spacer	40	1	A74165500	Stripper arm Winch 46 Rewind C <i>Stripper arm W46 Rewind C</i> <i>Peeler W46 Rewind C</i> <i>Spring stripper arm W46 Rewind</i> <i>Bushing</i> <i>Slider</i> <i>Screw M5x20 UNI 6109</i>
15			Winch Serial Number Sticker		1	S4165600F0	
16	1	S4129400A0	Stripper arm support		1	S416570001	
17	1	S281690097	Red line		1	S416580041	
18	4	M0601803	Screw UNI EN ISO 1207 - M6x35 - A4		1	S419170080	
19	3	M6007103	Screw M6x50 UNI6107		2	M0619003	
20	1	S416540004	Gear Z27				
21	1	S416280004	Main shaft W46 Rewind				
22	1	S416260041	Disconnect flange				
23	2	M0614103	Ball 5-16" inox				

*Available with service kit; see website www.harken.com

**Winch product sticker



Winch 46 Rewind™ STCW EL

CW = chrome/white

Pos.	Q.ty	Code	Description	Pos.	Q.ty	Code	Description
1	1	A94164101	W46 RW Base Assembly <i>W46 RW Base</i>	24	1	M0616603	Retaining ring UNI 7435 - Ø28
	1	S413350080	<i>Roller Ø6x19</i>	25	1	M0630802	Elastic ring SSR0137-S17
	1	S414890080	<i>Bushing Ø9xØ11x7</i>	26	1	S416250004	Pawls carrier Ø8xN2
	1	S413330085	<i>Bushing Ø12xØ14x11</i>	27	1	S416240041	Gear Z23
	1	S4130900A7	<i>Bushing Ø22xØ25x8.5</i>	28	1	S416300002	Disconnect rod 46 Rewind
	1	M6009463	<i>Spring loaded ball plunger Ø6</i>	29	1	S416530004	Pin for switch
2	1	A94164200W	Assy Skirt Winch 46 Rewind RAL9003 <i>Skirt W46 Rewind RAL 9003</i> <i>Winch Product Sticker**</i>	30	1	M0624203	Screw M6x30
3	1	S413300004	Pin Ø12x60	31	1	S418590001	Spring Ø10.67x12.7
4	1	S278170002	Washer Ø12.5xØ48x1.5	32	1	A74165000	Command x W46 Rewind
5	6	S000080003	Pawl Ø8*	33	1	S653520043	Drum 46 C rewind
6	6	S000380001	Pawl Spring Ø8*	34	1	A94191800	Assy knob W46 Rewind <i>Knob W46 Rewind</i> <i>Heli-coil M4x8</i> <i>Pin for knob</i> <i>Bushing Ø6.5xØ4x3</i>
7	1	S413250041	Pinion Z13		1	S419190004	
8	2	M6017694	Bushing PSM-1214-20		1	S419200041	
9	1	S413070004	Pin Ø9xØ12x32.5	35	1	S497400180	Knob Rewind
10	1	A94133400	Assy Gear Z12 <i>Gear Z12</i> <i>Bushing Ø12xØ14x8</i>	36	1	M0624103	Screw M4x16 UNI5931
	2	S414900080		37	1	A94165200	Assy socket Rewind <i>Socket Handle</i> <i>Washer Ø25xØ15x4</i> <i>Nut Screw for Disconnect Rod</i> <i>O ring RC 2025 series</i>
11	1	A96756700	W46 RW Housing Assembly <i>W46 RW Housing</i> <i>Bushing Ø12xØ14x8</i> <i>Bushing Ø12xØ14x11</i> <i>Bushing for support</i>		1	S414940085	
	1	S414900080			1	S414930003	
	1	S413330085			1	M0679797	
	1	S4133200B3		38	1	S6511900A5W	Cover 2 Speed W46 RW RAL 9003
12	5	M0606303	Screw M8x25 UNI 5931	39	1	A94192100W	Assy jaws Winch 46 STCW Rewind <i>Upper Jaw W46 RAL 9003</i> <i>Lower Jaw W46 Rewind</i> <i>SPRING</i>
13	2	A74133700	Bearing Ø75xØ87x26		4	S385970001	
14	1	S413390080	Spacer	40	1	A74165500	Stripper arm Winch 46 Rewind C <i>Stripper arm W46 Rewind C</i> <i>Peeler W46 Rewind C</i> <i>Spring stripper arm W46 Rewind</i> <i>Bushing</i> <i>Slider</i> <i>Screw M5x20 UNI 6109</i>
15			Winch Serial Number Sticker		1	S4165600F0	
16	1	S4129400A0	Stripper arm support		1	S416570001	
17	1	S281690097	Red line		1	S416580041	
18	4	M0601803	Screw UNI EN ISO 1207 - M6x35 - A4		1	S419170080	
19	3	M6007103	Screw M6x50 UNI6107		2	M0619003	
20	1	S416540004	Gear Z27				
21	1	S416280004	Main shaft W46 Rewind				
22	1	S416260041	Disconnect flange				
23	2	M0614103	Ball 5-16" inox				

 *Available with service kit; see website www.harken.com

**Winch product sticker



Winch 46 Rewind™ STBBB EL

BBB = all bronze

Pos.	Q.ty	Code	Description	Pos.	Q.ty	Code	Description
1	1	A94164101	W46 RW Base Assembly <i>W46 RW Base</i>	24	1	M0616603	Retaining ring UNI 7435 - Ø28
	1	S413350080	<i>Roller Ø6x19</i>	25	1	M0630802	Elastic ring SSR0137-S17
	1	S414890080	<i>Bushing Ø9xØ11x7</i>	26	1	S416250004	Pawls carrier Ø8xN2
	1	S413330085	<i>Bushing Ø12xØ14x11</i>	27	1	S416240041	Gear Z23
	1	S4130900A7	<i>Bushing Ø22xØ25x8.5</i>	28	1	S416300002	Disconnect rod 46 Rewind
	1	M6009463	<i>Spring loaded ball plunger Ø6</i>	29	1	S416530004	Pin for switch
2	1	A96938300	Assy Skirt Winch 46 BBB Rewind <i>Skirt W46.2 RW BBB</i> <i>Winch Product Sticker**</i>	30	1	M0624203	Screw M6x30
3	1	S413300004	Pin Ø12x60	31	1	S418590001	Spring Ø10.67x12.7
4	1	S278170002	Washer Ø12.5xØ48x1.5	32	1	A74165000	Command x W46 Rewind
5	6	S000080003	Pawl Ø8*	33	1	S693840043	Drum W46 BBB Rewind
6	6	S000380001	Pawl Spring Ø8*	34	1	A94191800	Assy knob W46 Rewind <i>Knob W46 Rewind</i> <i>Heli-coil M4x8</i>
7	1	S413250041	Pinion Z13		1	S419190004	<i>Pin for knob</i>
8	2	M6017694	Bushing PSM-1214-20		1	S419200041	<i>Bushing Ø6.5xØ4x3</i>
9	1	S413070004	Pin Ø9xØ12x32.5	35	1	S497400180	Knob Rewind
10	1	A94133400	Assy Gear Z12 <i>Gear Z12</i>	36	1	M0624103	Screw M4x16 UNI5931
	2	S414900080	<i>Bushing Ø12xØ14x8</i>	37	1	A94165200	Assy socket Rewind <i>Socket Handle</i>
11	1	A96756700	W46 RW Housing Assembly <i>W46 RW Housing</i>		1	S414940085	<i>Washer Ø25xØ15x4</i>
	1	S414900080	<i>Bushing Ø12xØ14x8</i>		1	S414930003	<i>Nut Screw for Disconnect Rod</i>
	1	S413330085	<i>Bushing Ø12xØ14x11</i>		1	M0679797	<i>O ring RC 2025 series</i>
	1	S4133200B3	<i>Bushing for support</i>	38	1	A76938800	Cover W46 BBB Rewind
12	5	M0606303	Screw M8x25 UNI 5931	39	1	A96938500	Assy jaws Winch 46 BBB Rewind <i>Lower Jaw W46 BBB Rewind</i> <i>Upper Jaw W46</i>
13	2	A74133700	Bearing Ø75xØ87x26		4	S385970001	<i>SPRING</i>
14	1	S413390080	Spacer	40	1	A76938600	Stripper arm Winch 46 BBB Rewind <i>Stripper arm W46 BBB Rewind</i>
15			Winch Serial Number Sticker		1	S6938700F0	<i>Peeler W46 BBB Rewind</i>
16	1	S4129400A0	Stripper arm support		1	S416570001	<i>Spring stripper arm W46 Rewind</i>
17	1	S281690097	Red line		1	S416580041	<i>Bushing</i>
18	4	M0601803	Screw UNI EN ISO 1207 - M6x35 - A4		1	S419170080	<i>Slider</i>
19	3	M6007103	Screw M6x50 UNI6107		2	M0619003	<i>Screw M5x20 UNI 6109</i>
20	1	S416540004	Gear Z27				
21	1	S416280004	Main shaft W46 Rewind				
22	1	S416260041	Disconnect flange				
23	2	M0614103	Ball 5-16" inox				

*Available with service kit; see website www.harken.com

**Winch product sticker



Winch 46 Rewind™ STCCC EL

CCC = All-Chrome bronze

Pos.	Q.ty	Code	Description	Pos.	Q.ty	Code	Description
1	1	A94164101	W46 RW Base Assembly <i>W46 RW Base</i>	24	1	M0616603	Retaining ring UNI 7435 - Ø28
	1	S413350080	<i>Roller Ø6x19</i>	25	1	M0630802	Elastic ring SSR0137-S17
	1	S414890080	<i>Bushing Ø9xØ11x7</i>	26	1	S416250004	Pawls carrier Ø8xN2
	1	S413330085	<i>Bushing Ø12xØ14x11</i>	27	1	S416240041	Gear Z23
	1	S4130900A7	<i>Bushing Ø22xØ25x8.5</i>	28	1	S416300002	Disconnect rod 46 Rewind
	1	M6009463	<i>Spring loaded ball plunger Ø6</i>	29	1	S416530004	Pin for switch
2	1	A96938000	Assy Skirt Winch 46 CCC Rewind <i>Skirt W46.2 RW CCC</i> <i>Winch Product Sticker**</i>	30	1	M0624203	Screw M6x30
3	1	S413300004	Pin Ø12x60	31	1	S418590001	Spring Ø10.67x12.7
4	1	S278170002	Washer Ø12.5xØ48x1.5	32	1	A74165000	Command x W46 Rewind
5	6	S000080003	Pawl Ø8*	33	1	S653520043	Drum 46 C rewind
6	6	S000380001	Pawl Spring Ø8*	34	1	A94191800	Assy knob W46 Rewind <i>Knob W46 Rewind</i> <i>Heli-coil M4x8</i> <i>Pin for knob</i> <i>Bushing Ø6.5xØ4x3</i>
7	1	S413250041	Pinion Z13		1	S419190004	
8	2	M6017694	Bushing PSM-1214-20		1	S419200041	
9	1	S413070004	Pin Ø9xØ12x32.5	35	1	S497400180	Knob Rewind
10	1	A94133400	Assy Gear Z12 <i>Gear Z12</i> <i>Bushing Ø12xØ14x8</i>	36	1	M0624103	Screw M4x16 UNI5931
	2	S414900080		37	1	A94165200	Assy socket Rewind <i>Socket Handle</i> <i>Washer Ø25xØ15x4</i> <i>Nut Screw for Disconnect Rod</i> <i>O ring RC 2025 series</i>
11	1	A96756700	W46 RW Housing Assembly <i>W46 RW Housing</i> <i>Bushing Ø12xØ14x8</i> <i>Bushing Ø12xØ14x11</i> <i>Bushing for support</i>		1	S414940085	
	1	S414900080			1	S414930003	
	1	S413330085			1	M0679797	
	1	S4133200B3		38	1	A76938200	Cover W46 CCC Rewind
12	5	M0606303	Screw M8x25 UNI 5931	39	1	A96938100	Assy jaws Winch 46 CCC Rewind <i>Lower Jaw W46 Rewind CCC</i> <i>Upper Jaw W46 RAL 9003</i> <i>SPRING</i>
13	2	A74133700	Bearing Ø75xØ87x26		4	S385970001	
14	1	S413390080	Spacer	40	1	A74165500	Stripper arm Winch 46 Rewind C <i>Stripper arm W46 Rewind C</i> <i>Peeler W46 Rewind C</i> <i>Spring stripper arm W46 Rewind</i> <i>Bushing</i> <i>Slider</i> <i>Screw M5x20 UNI 6109</i>
15			Winch Serial Number Sticker		1	S4165600F0	
16	1	S4129400A0	Stripper arm support		1	S416570001	
17	1	S281690097	Red line		1	S416580041	
18	4	M0601803	Screw UNI EN ISO 1207 - M6x35 - A4		1	S419170080	
19	3	M6007103	Screw M6x50 UNI6107		2	M0619003	
20	1	S416540004	Gear Z27				
21	1	S416280004	Main shaft W46 Rewind				
22	1	S416260041	Disconnect flange				
23	2	M0614103	Ball 5-16" inox				

*Available with service kit; see website www.harken.com

**Winch product sticker



Horizontal electric motor 12V/24V

TOP VIEW

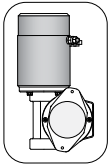

* Motor installed in right-hand configuration.

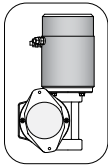

** Motor installed in left-hand configuration.

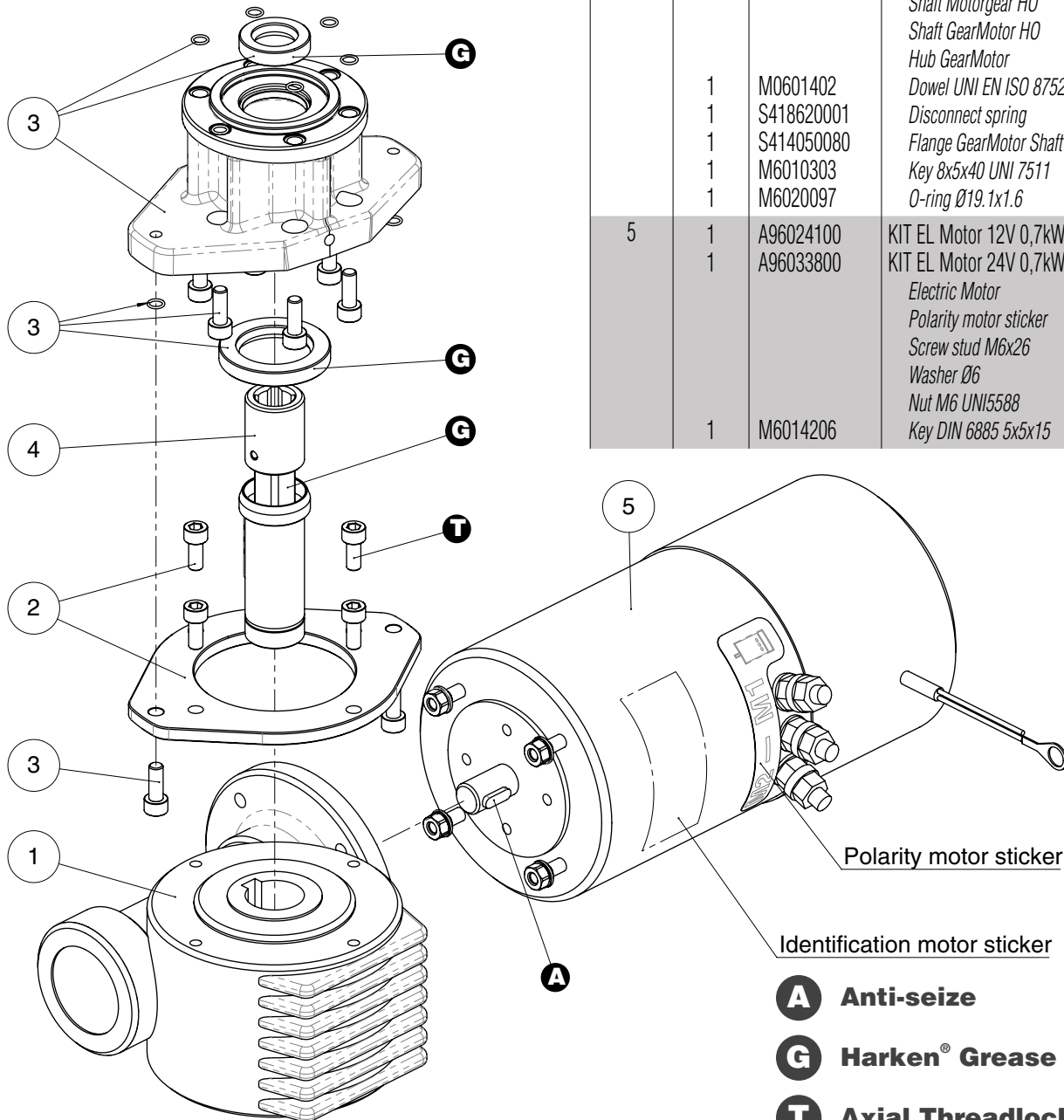

Pos.	Q.ty	Code	Description
1	1	A93127900	KIT Gear Reduction 1/24
	1	A94194900	KIT LM Gear Reduction 1/24
2	1	A94149200	KIT Assy Electric Motor Flange
	1	A94149200L	KIT Assy Electric Motor Flange Left
	4	M0606803	Screw M6x14 UNI 5931
3	1	A94149500	KIT EL HO Motor Flange
	8	S415360003	Screw M6x16 UNI EN ISO 5931:2003 precote coating
	8	M6015697	O-Ring Seal ORM 0055-10 (Ø5,5xØ1)
	1	M6007297	Lip seal Ø17xØ30x7
	1	M0612097	Sealer Ø30xØ47x7
4	1	A94161600	KIT EL HO Motor Clutch
			Shaft Motorgear HO
			Shaft GearMotor HO
			Hub GearMotor
	1	M0601402	Dowel UNI EN ISO 8752:2000- Ø4x24
	1	S418620001	Disconnect spring
1	S414050080	Flange GearMotor Shaft HO	
1	M6010303	Key 8x5x40 UNI 7511	
1	M6020097	O-ring Ø19.1x1.6	
5	1	A96024100	KIT EL Motor 12V 0,7kW
	1	A96033800	KIT EL Motor 24V 0,7kW
			Electric Motor
			Polarity motor sticker
			Screw stud M6x26
			Washer Ø6
			Nut M6 UNI5588
	1	M6014206	Key DIN 6885 5x5x15

- A** Anti-seize
- G** Harken® Grease
- T** Axial Threadlocker

Horizontal electric motor 24V H82

TOP VIEW

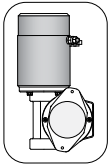

* Motor installed in right-hand configuration.

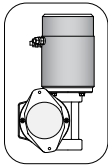

** Motor installed in left-hand configuration.

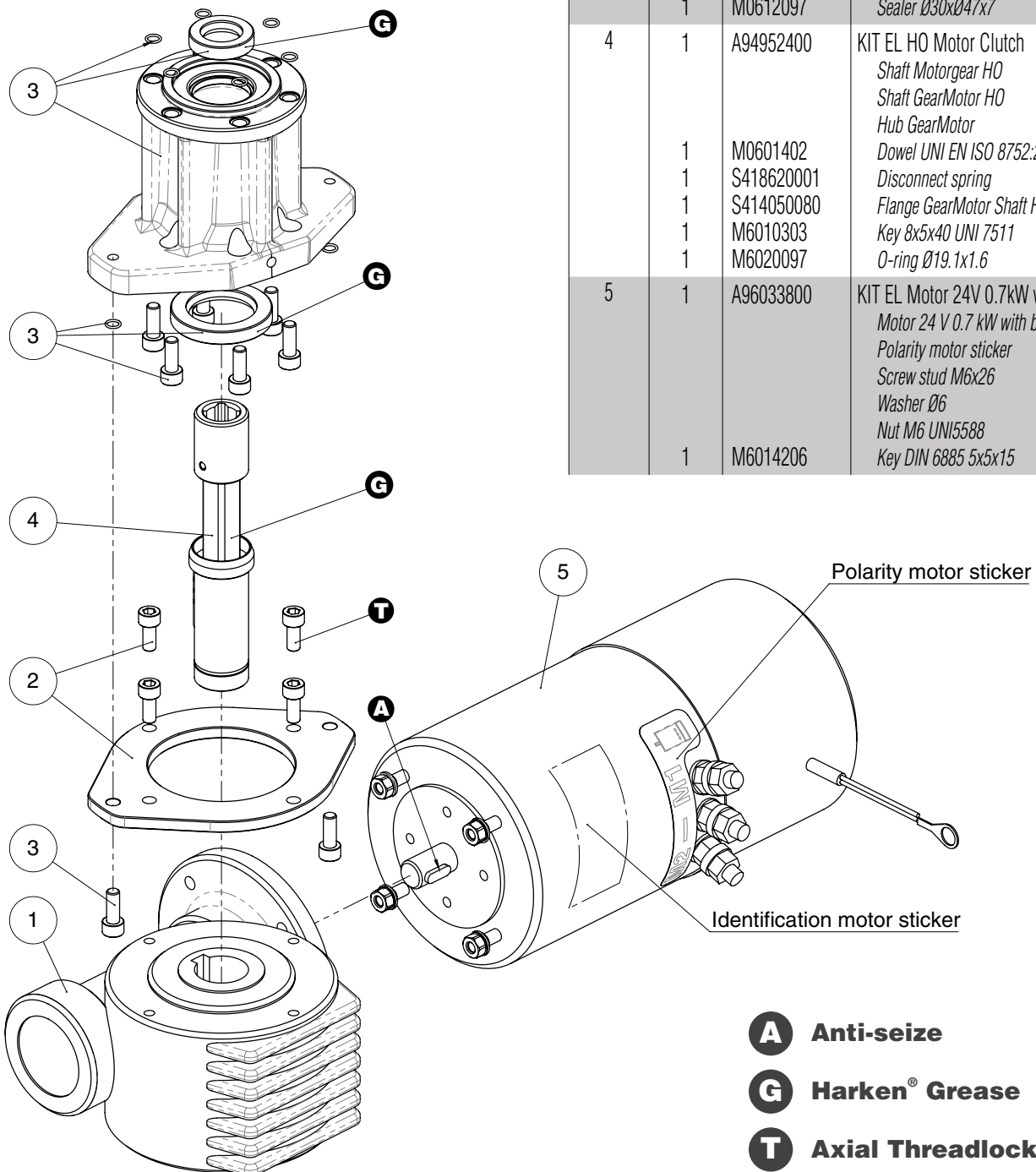

Pos.	Q.ty	Code	Description
1	1	A93127900	KIT Gear Reduction 1/24
	1	A94194900	KIT LM Gear Reduction 1/24
2	1	A94149200	KIT Assy Electric Motor Flange
	1	A94149200L	KIT Assy Electric Motor Flange Left
			Electric Motor Flange
	4	M0606803	Screw M6x14 UNI 5931
3	1	A94966500	KIT EL HO Motor Flange (H82)
			Horizontal Motorgear Flange
	8	S415360003	Screw M6x16 UNI EN ISO 5931:2003 precote coating
	8	M6015697	O-Ring Seal ORM 0055-10 (Ø5,5xØ1)
	1	M6007297	Lip seal Ø17xØ30x7
	1	M0612097	Sealer Ø30xØ47x7
4	1	A94952400	KIT EL HO Motor Clutch
			Shaft Motorgear HO
			Shaft GearMotor HO
			Hub GearMotor
	1	M0601402	Dowel UNI EN ISO 8752:2000- Ø4x24
	1	S418620001	Disconnect spring
	1	S414050080	Flange GearMotor Shaft HO
1	M6010303	Key 8x5x40 UNI 7511	
1	M6020097	O-ring Ø19.1x1.6	
5	1	A96033800	KIT EL Motor 24V 0.7kW with brake
			Motor 24 V 0.7 kW with brake
			Polarity motor sticker
			Screw stud M6x26
			Washer Ø6
			Nut M6 UNI5588
	1	M6014206	Key DIN 6885 5x5x15

- A** Anti-seize
- G** Harken® Grease
- T** Axial Threadlocker