

Radial Winch 50.2 PTBBB, PTCCC

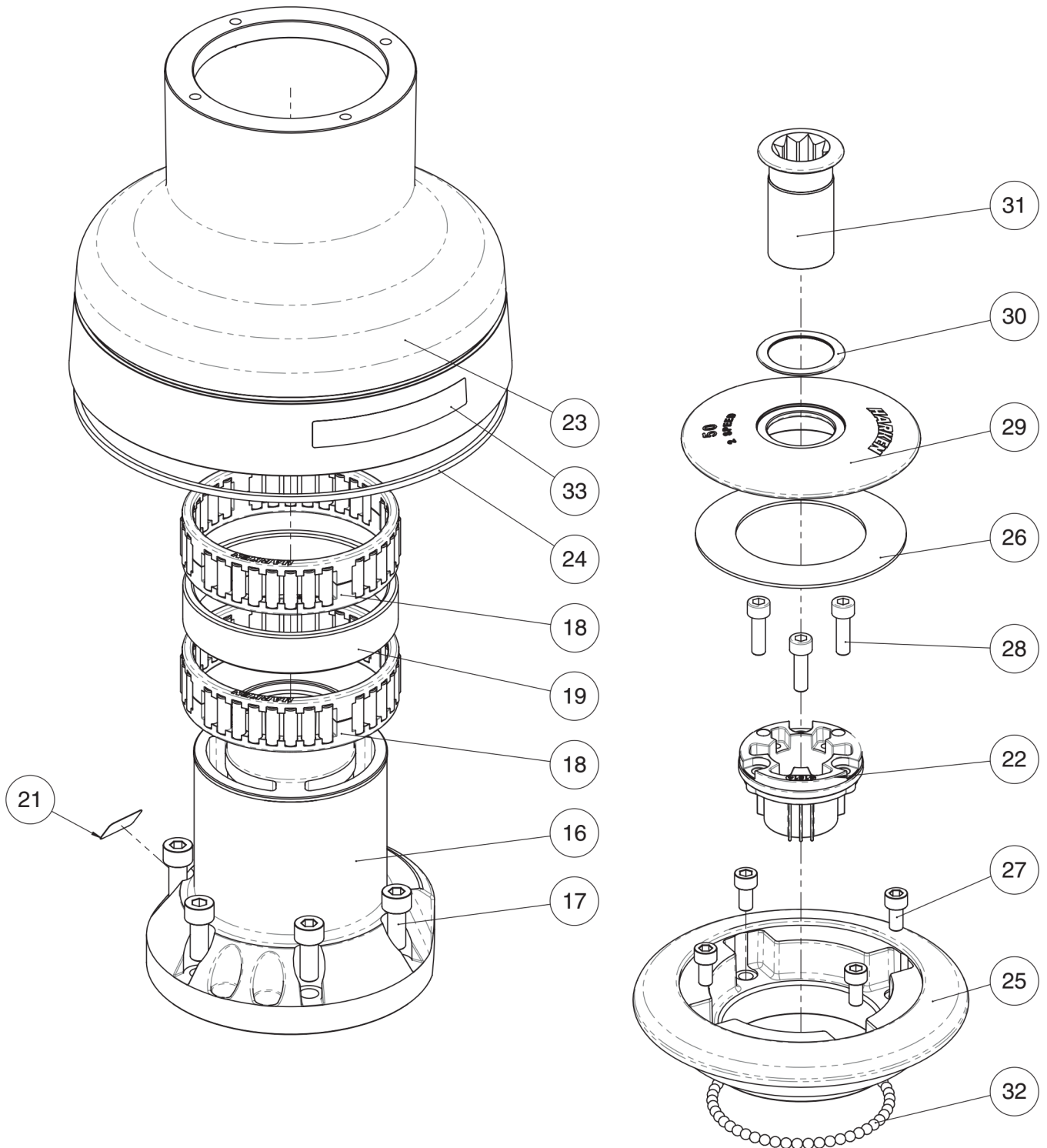

Radial Winch 50.2 PTBBB, PTCCC

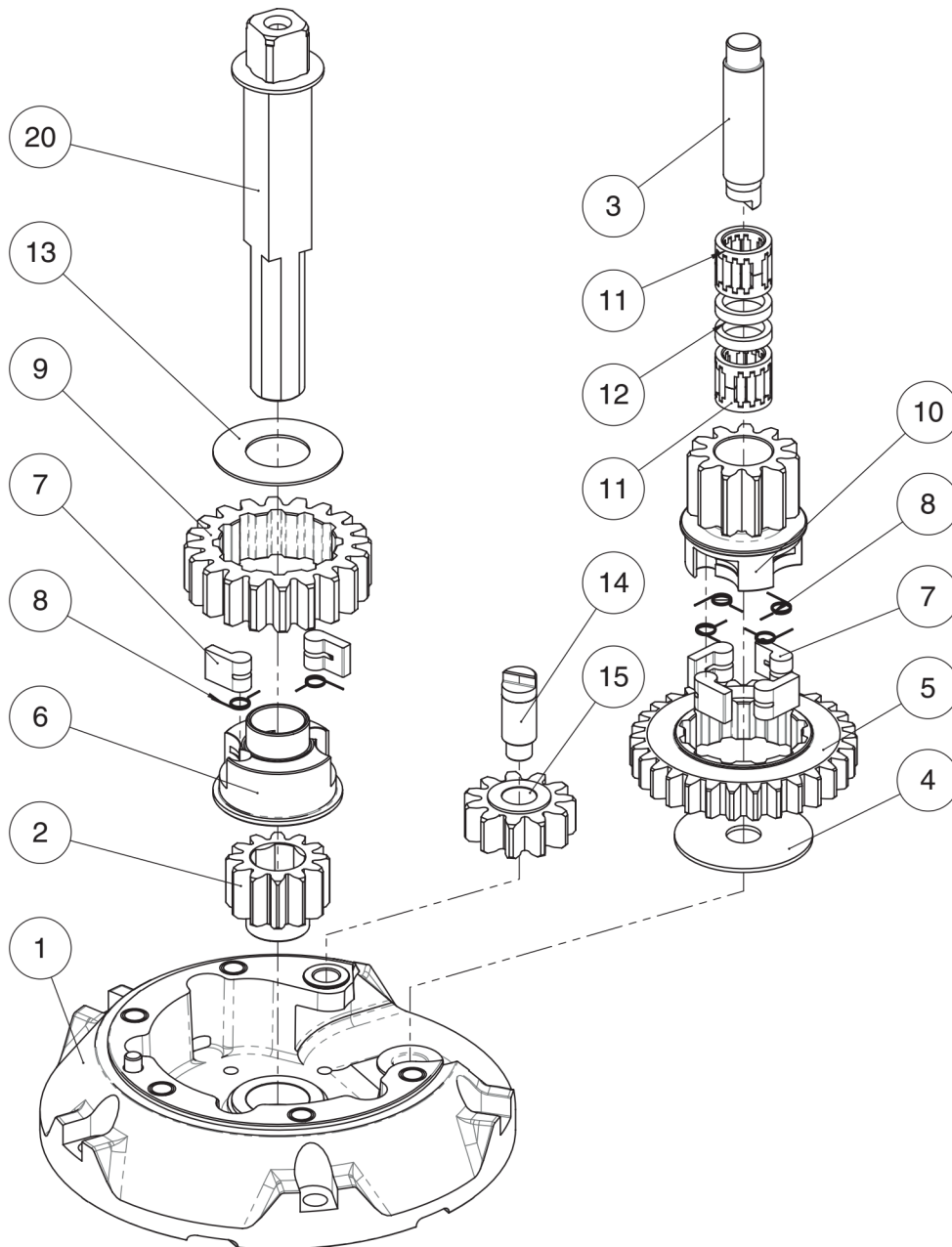

Radial Winch 50.2 PTBBB

BBB = all bronze

Pos.	Q.ty	Code	Description	Pos.	Q.ty	Code	Description
1	1	A96633400	PERFORMA Assy Base Winch 50 <i>PERFORMA Base W50 Heli-coil M8x10</i>	18	2	A74135100	Bearing Ø85xØ97x26
	1	S413350080	<i>Roller Ø6x19</i>	19	1	S413520080	Spacer
	1	S4152300A7	<i>Bushing Ø22xØ25x9.5</i>	20	1	A94152000	Assy Central Shaft W50 <i>Washer Ø17.2xØ32x1.5</i>
	1	S414890080	<i>Bushing Ø9xØ11x7</i>	1	1	S415200002	<i>Central shaft W50 PT</i>
	1	S413330085	<i>Bushing Ø12xØ14x11</i>	21			Winch Serial Number Sticker
2	1	S413020004	Gear Z12	22	1	S4151400A0	Socket Support PT
3	1	S416050004	Pin	23	1	S688140043	Drum W50 B
4	1	S278170002	Washer Ø12.5xØ48x1.5	24	1	S281690097	Red line
5	1	S412800041	Gear Z30	25	1	S688020043	Plain Top W50 PT BBB
6	1	S414260004	Pawls Carrier Ø8xN2	26	1	S678730082	Washer Ø57.5xØ93x1.5
7	6	S000080003	Pawl Ø8*	27	4	M0603703	Screw M6x12 UNI 5931
8	6	S000380001	Pawl Spring Ø8*	28	3	M0600903	Screw M6x20 UNI5931
9	1	S415590041	Gear Z20	29	1	S688100043	Cover W50 PT BBB
10	1	S415610004	Pinion Z11	30	1	S415220080	PT spacer
11	2	A72821800	Roller Bearing Ø14xØ20x18	31	1	A94136400	Assy Socket W20-80 <i>Socket Handle W20/80</i>
12	2	S281340080	Spacer roller bearings	1	1	S415130085	<i>Washer Ø7.7xØ25x5.8</i>
13	1	S413120002	Washer Ø22.5xØ45x1	1	1	M0614303	<i>Screw M8x20 UNI 6109</i>
14	1	S413070004	Pin Ø9xØ12x32.5	32	50	M0619580	Ball 3/16"
15	1	A94156000	Assy Gear Z11 <i>Gear Z11</i>	33			Winch Product Sticker**
	2	S414900080	<i>Bushing Ø12xØ14x8</i>				
16	1	A94134800	Assy Housing Winch 50 <i>Housing Winch 50 Heli-coil M6x9</i>				
	1	S414900080	<i>Bushing Ø12xØ14x8</i>				
	1	S413330085	<i>Bushing Ø12xØ14x11</i>				
	1	S4133200B3	<i>Bushing for support</i>				
17	5	M0643203	Screw M8x20 UNI5931				

*Available with service kit; see website www.harken.com

**Winch product sticker

