

Exploded view

Radial Winch 50.2 STA, STC, STCW

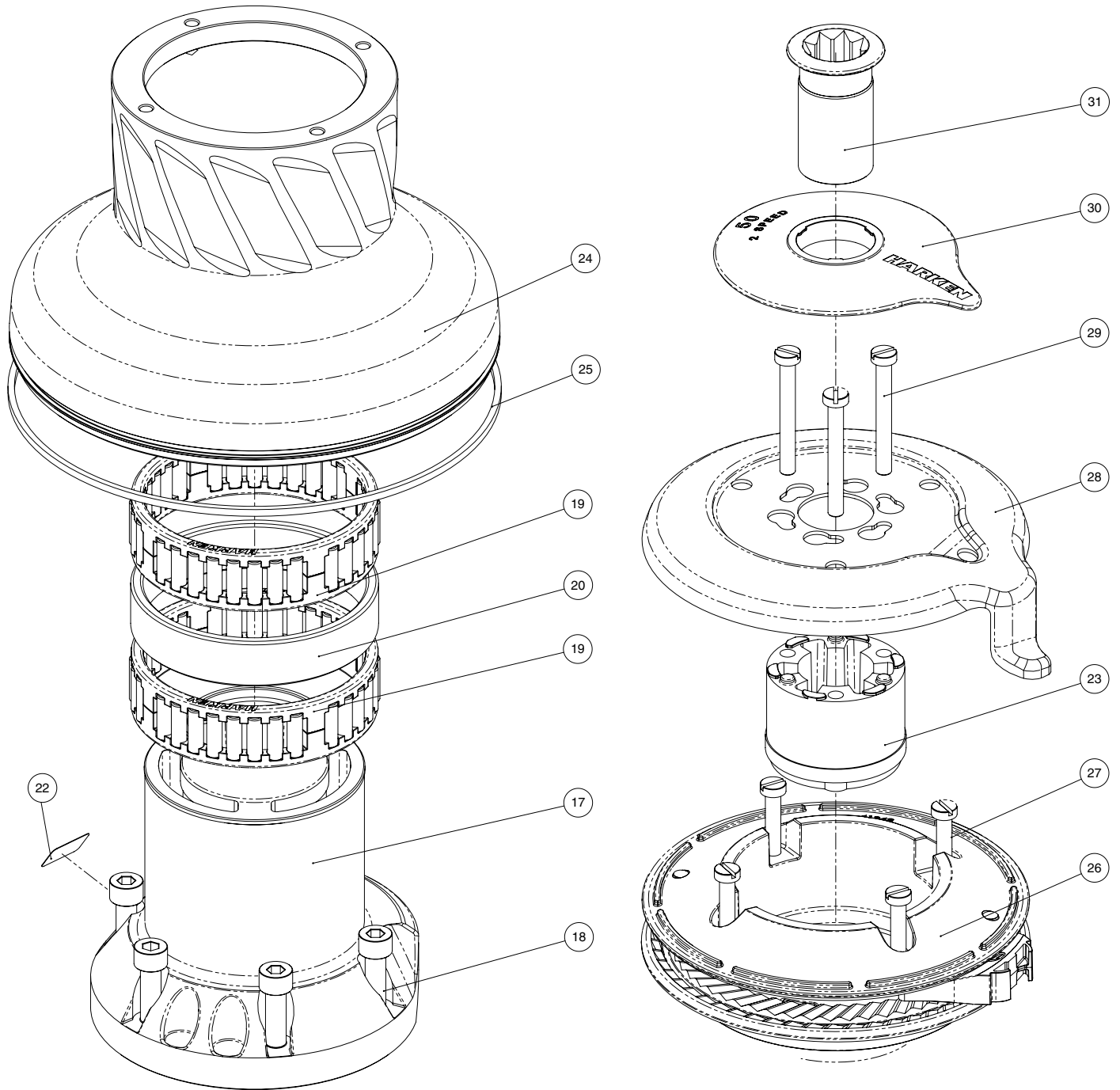

Radial Winch 50.2 STA, STC, STCW

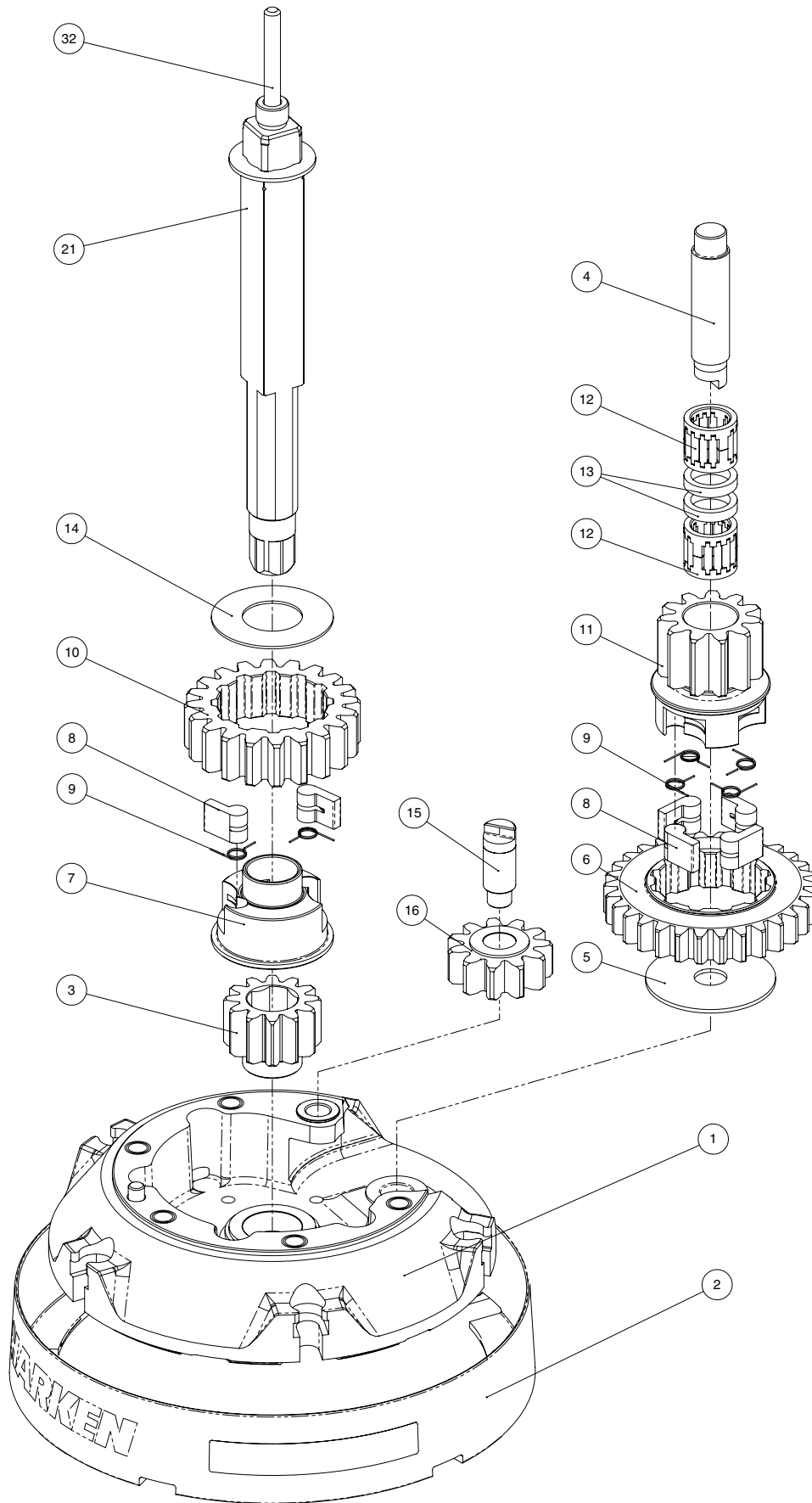

Parts List

Radial Winch 50.2 STA

A = drum in anodised aluminium

Pos.	Q.ty	Code	Description	Pos.	Q.ty	Code	Description
1	1	A94189800	Assy Base Winch 50 EL/HY <i>Base W50 Heli-coil M8x10</i>	18	5	M0606303	Screw M8x25 UNI 5931
	1	S413350080	<i>Roller Ø6x19</i>	19	2	A74135100	Bearing Ø85xØ97x26
	1	S4130900A7	<i>Bushing Ø22xØ25x8.5</i>	20	1	S413520080	Spacer
	1	S414890080	<i>Bushing Ø9xØ11x7</i>	21	1	A96753100	Assy Central Shaft Winch 50 <i>Central Shaft Pred. W50</i>
	1	S413330085	<i>Bushing Ø12xØ14x11</i>		1	S413880002	<i>Washer Ø17.2xØ32x1.5</i>
2	1	A94134900	Assy Skirt Winch 50 <i>Skirt W50 Winch Product Sticker**</i>	22			Winch Serial Number Sticker
3	1	S413020004	Gear Z12	23	1	S4129400A0	Stripper arm support
4	1	S416050004	Pin	24	1	S413400053	Drum W50
5	1	S278170002	Washer Ø12.5xØ48x1.5	25	1	S281690097	Red line
6	1	S412800041	Gear Z30	26	1	A94134300	Assy Jaws Winch 50 <i>Lower Jaw W50 Upper Jaw W50</i>
7	1	S414260004	Pawls Carrier Ø8xN2		1	S414280080	<i>Peeler W46 - 50</i>
8	6	S000080003	Pawl Ø8*		4	S385970001	<i>SPRING</i>
9	6	S000380001	Pawl Spring Ø8*	27	4	M0601803	Screw UNI EN ISO 1207:1996 - M6x35 - A4
10	1	S415590041	Gear Z20	28	1	S413440019	Stripper Arm W50
11	1	S415610004	Pinion Z11	29	3	M6007103	Screw M6x50 UNI6107
12	2	A72821800	Roller Bearing Ø14xØ20x18	30	1	S4134500A5	Cover 2 speed W50
13	2	S281340080	Spacer roller bearings	31	1	A94149300	Assy Socket W35-80 EL/HY <i>Socket Handle W20/80</i>
14	1	S413120002	Washer Ø22.5xØ45x1		1	S414940085	<i>Washer Ø25xØ15x4</i>
15	1	S413070004	Pin Ø9xØ12x32.5		1	S414930003	<i>Nut Screw for Disconnect Rod</i>
16	1	A94156000	Assy Gear Z11 <i>Gear Z11</i>		1	M0679797	<i>O ring RC 2025 series</i>
	2	S414900080	<i>Bushing Ø12xØ14x8</i>	32	1	S415070002	Disconnect Rod W50
17	1	A94134800	Assy Housing Winch 50 <i>Housing Winch 50 Heli-coil M6x9</i>				
	1	S414900080	<i>Bushing Ø12xØ14x8</i>				
	1	S413330085	<i>Bushing Ø12xØ14x11</i>				
	1	S4133200B3	<i>Bushing for support</i>				

*Available with service kit; see website www.harken.com

**Winch product sticker



Hydraulic motor

Pos.	Q.ty	Code	Description	Pos.	Q.ty	Code	Description
1	1	G045942000Y	Hydraulic motor W46-60	4	1	A94149100	KIT HY Motor Flange W46-70
2	1	S415000080	Hydraulic Motor Spacer	6	1	S415360003	Hydraulic Motorgear Flange Screw M6x16 UNI EN ISO 5931:2003 precote coating
3	1	A94193200	KIT Clutch HY Motor W46-70	6	1	M6015697	O-Ring Seal ORM 0055-10 (Ø5,5 x Ø1)
			Toothed coupling	6	1	M6007297	Lip seal Ø17xØ30x7
	1	M0620401	Connecting Coupling Ø31.5	1	1	M0621503	Washer D.13 U1751 DIN127
	1	S415010080	Spring pin 5x40 DIN1481	2	1	M0667103	Screw M12x35 UNI5931
	1	S326490001	Bushing				
	1	S329360082	Spring				
	1	M0635303	Washer				
	1		Screw M8x16 UNI6109				

