

Performa Winch 60.3 STP E/HY

Pos	Q.ty	Code	Description	Pos	Q.ty	Code	Description
1	1	A 965745 00	Performa Assy Base W60 EL/HY W60 Performance Base Heli-coil M8x10 Centering bushing Ø12 Bushing Ø22xØ25x8.5* Bushing Ø12xØ35x9* Winch Product Sticker**	21	1	S 41557 00 A0	Stripper arm support
2	1	S 41440 00 04	Gear Z14 W60	22	1	A 965559 00	Performa Assy Jaws W60 Lower Jaw W60 Upper Jaw W60 Peeler W60 - 70 Spring
3	1	S 41303 00 04	Pawls Carrier Ø8xN2	23	1	A 765375 01	Performa Drum Assembly W60
4	8	S000090004	Pawl Ø 8	24	47	M 06102 80	Ball 5/16**
5	8	S 00038 00 01	Pawl Spring dia 8*	25	4	M0601803	Vite UNI EN ISO 1207:1996 - M6x35 - A4
6	1	S 41439 00 41	Ratchet Gear Z21xN2	26	1	S 65741 00 19	Performa Black Stripper Arm W60
7	1	S 41312 00 02	Washer Ø22.5xØ45x1*	27	3	M0601903	Screw M6x16 UNI1207*
8	1	S278170002	Washer 12.5x48x1.5*	28	1	S 41675 00 B1	Cover 3 Speed W60
9	1	S 28101 00 04	Pin for gear	29	1	A 941914 00	Assy Socket Handle Winch 3spd EL/HY Socket Handle 3 speed Washer ø25xø15x4 Nut Screw for Disconnect Rod O ring RC 2025 series
10	1	S 41442 00 41	Ratchet Gear Z26xN4	30	1	S280870041	Gear 1V
11	1	S 41441 00 04	Pawls Carrier Gear Z13 N4	31	1	S 41458 00 81	Shim Bushing 3 speed*
12	2	A72821800	Roller Bearing 14/20/18	32	1	S 41540 00 04	Pawls Carrier 3 speed
13	1	S 41603 00 04	Gear Pin Ø12xØ18x52,5	33	1	A73129200	ROLLER BEARING 50-62-20 ERTA P*
14	1	S 41448 00 04	Idler and Pinion Z23/Z13 W60	34	1	S 37751 00 01	Clutch Spring
15	2	A 741623 00	Roll bearing 24x18x18	35	1	A73422600	Bearing 45x55x12*
16	1	A 941908 00	Assy Housing Winch 60.3 Housing W60 Bushing Ø12xØ35x9* Heli-coil M6x9 Bushing	36	1	A 941580 00	Assy Clutch 3rd spd W60 Assy Command tube W60 Dog Clutch 3 speed Spring loaded ball plunger Ø6
17	6	M0606303	Screw M8x25 UNI 5931	37	1	S 41902 00 02	Disconnect rod W60.3
18	3	A 741450 00	Roller Bearing Ø95xØ107x26*	38	1	A 941453 00	Assy Gear 3rd speed Idler Gear 3 speed Bushing Ø22/Ø25x15.5 Washer 3 velocità Screw M6x12 UNI 5933
19	1	A 967536 00	Assy Central Shaft Winch 60 EL/HY Central Shaft Pred. W60 Washer Ø17.2xØ32x1.5				
20	1	S 41876 00 63	Winch Serial Number Sticker				

*Service kit available; see winch kit section on the website www.harken.com

**Winch product sticker



Horizontal electric motor

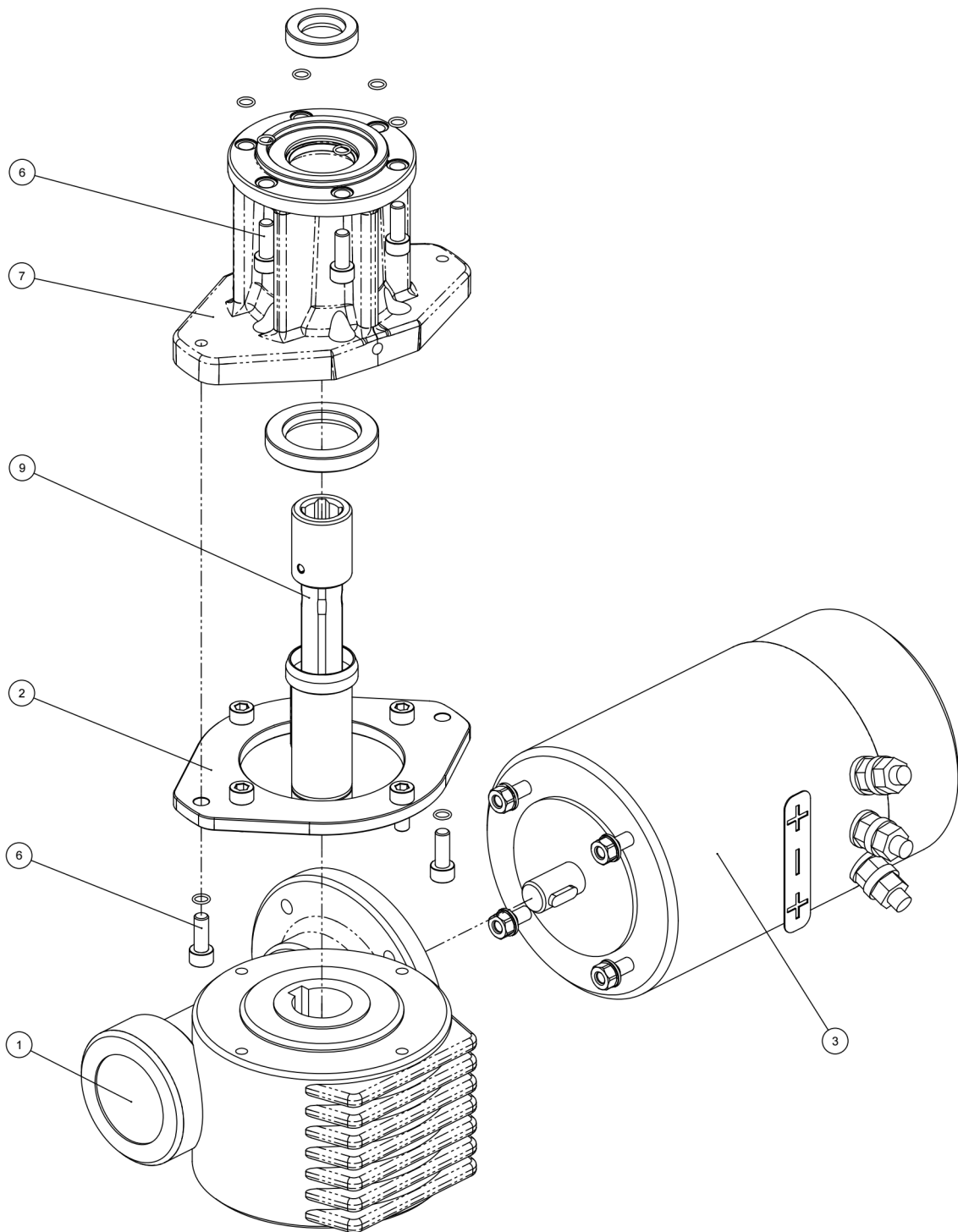

TOP VIEW

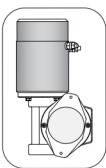

*** Motor installed in right-hand configuration.**

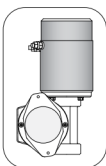

**** Motor installed in left-hand configuration.**

Pos	Q.ty	Code	Description
1	1	A 931279 00	KIT Gear Reduction VF49*
	1	A 941949 00	KIT LM Gear Reduction VF49**
2	1	A 941492 00	KIT Assy Electric Motor Flange
3	1	A 960107 00	KIT EL Motor 12V 1,5kW
	1	A 960106 00	KIT EL Motor 24V 2kW
4	1	M0612097	Sealer 30x47x7
5	1	M6007297	Lip seal 17x30x7
6	1	S 41536 00 03	Screw M6x16 UNI EN ISO 5931:20
7	1	S496650053	Horizontal Motorgear Flange
8	1	M6015697	O-Ring Seal ORM 0055-10 (Ø5,5 x Ø1)
9	1	A 965890 00	Performa KIT EL HO Motor Clutch