

Installation and Maintenance Manual

MRPW-D

Powered Performa™ Winch **60.3 STP E/HY**



HARKEN®

Introduction	3
Technical characteristics	3
<i>Performance data</i>	3
<i>Weight</i>	4
<i>Maximum working load</i>	4
Outline	5
<i>Winch 60.3 STP</i>	5
<i>Horizontal electric motor</i>	5
<i>Vertical electric motor</i>	5
<i>Hydraulic motor</i>	5
Installation	6
<i>Installation procedure</i>	7
<i>Winch installation procedure</i>	9
<i>Positioning the self-tailing arm</i>	10
<i>Motor installation procedure</i>	10
<i>Electric equipment</i>	11
<i>Hydraulic connections diagram</i>	13
Maintenance	14
<i>Washing</i>	14
<i>Maintenance table</i>	14
<i>Winch disassembly procedure</i>	14
<i>Winch exploded view with maintenance products</i>	18
<i>Winch assembly</i>	19
Harken® limited worldwide warranty	20
Ordering spare parts	20
Exploded view	21
<i>Performa Winch 60.3 STP EL/HY</i>	21
<i>Horizontal electric motor</i>	24
<i>Vertical electric motor</i>	25
<i>Hydraulic motor</i>	26
Parts list	23
<i>Performa Winch 60.3 STP EL/HY</i>	23
<i>Horizontal electric motor</i>	24
<i>Vertical electric motor</i>	25
<i>Hydraulic motor</i>	26

Introduction

This manual gives technical information on winch installation and maintenance, including disassembling and reassembling.

This information is DESTINED EXCLUSIVELY for specialised personnel or expert users.

Installation, disassembling and reassembling of the winch by personnel who are not experts may cause serious damage to users and those in the vicinity of the winch.

Harken® accepts no responsibility for defective installation or reassembly of its winches.

In case of doubt the Harken® Tech Service is at your disposal at techservice@harken.it

This Manual is available only in English. If you do not fully understand the English language, do not carry out the operations described in this Manual.

Technical characteristics

	Power ratio	Gear ratio
1st speed	9,2 : 1	2,2 : 1
2nd speed	20,3 : 1	4,8 : 1
3rd speed	61,0 : 1	14,4 : 1

The theoretical power ratio does not take friction into account.

Performance data

Winch 60.3 STP EL (electric)

	horizontal motor					
	12 V (1500 W)			24 V (2000 W)		
	1st speed	2nd speed	3rd speed	1st speed	2nd speed	3rd speed
line speed (m/min)**	38,8	17,7	5,9	46,8	21,4	7,1
max load (Kg)	290	600	1800	290	600	1800

***Line speed is measured with no load*

	vertical motor					
	12 V (1500 W)			24 V (2000 W)		
	1st speed	2nd speed	3rd speed	1st speed	2nd speed	3rd speed
line speed (m/min)**	44,5	20,3	6,8	53,5	24,4	8,1
max load (Kg)	290	600	1800	290	600	1800

***Line speed is measured with no load*

		motor nominal power (W)		current absorption at winch MWL (A)	
		12 V	24 V	12 V	24 V
winch 60.3 ST EL	horizontal	1500	2000	250	140
	vertical			225	120

Winch 60.3 ST HY (hydraulic)

	1st speed	2nd speed	3rd speed
line speed (m/min)*	66,5	30,3	10,1
max load (Kg)**	290	600	1800

* at 20 L/min oil flow (5,28 Gall/min)

** at 140 bar at 20 l/min

NOTE

The ratio of the line load - pressure is evaluated at nominal flow rate.

The performance is evaluated measuring the pressure and flow on the motor ports.

The performance data are based on oil with a viscosity of 35mm² /s [165 SUS] and temperature of 50°C [120°F].

Weight

	ST EH	ST EV	ST H
weight (Kg)	23,2	22,1	19,2

Versions:

EH = horizontal electric winch

EV = vertical electric winch

H = vertical hydraulic winch

Maximum working load



WARNING!

The maximum working load (MWL) for the 60.3 ST Performa™ Winch is 1800 Kg (3968 lb). Subjecting the winch to loads above the maximum working load can cause the winch to fail or pull off the deck suddenly and unexpectedly during high loads causing severe injury or death.

Outline

Winch 60.3 STP EL/HY

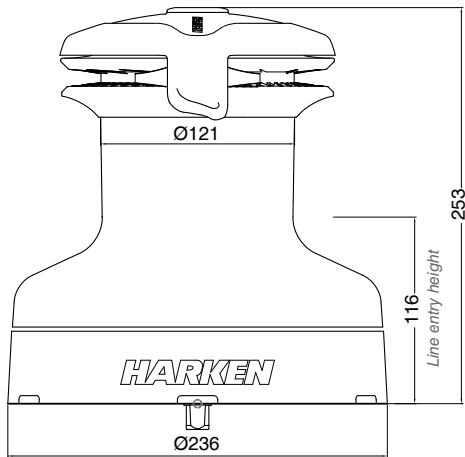

Horizontal electric motor (12 V / 24 V)

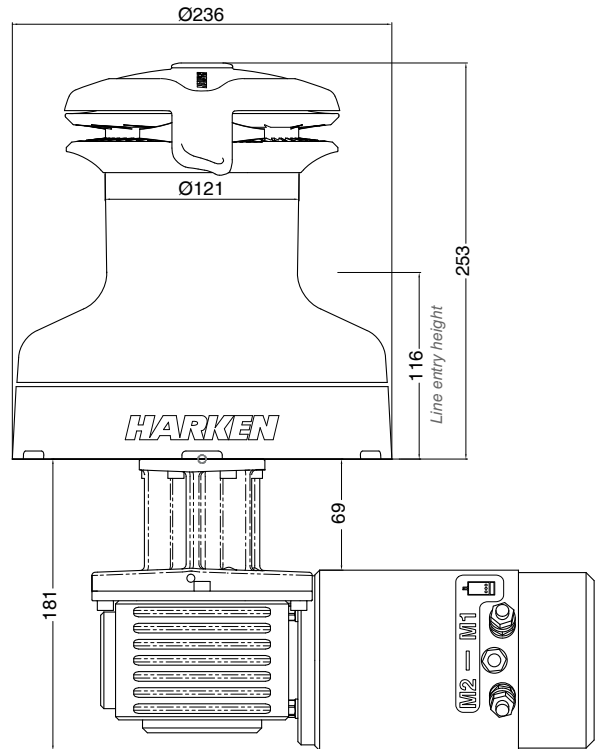

Vertical electric motor (12 V / 24 V)

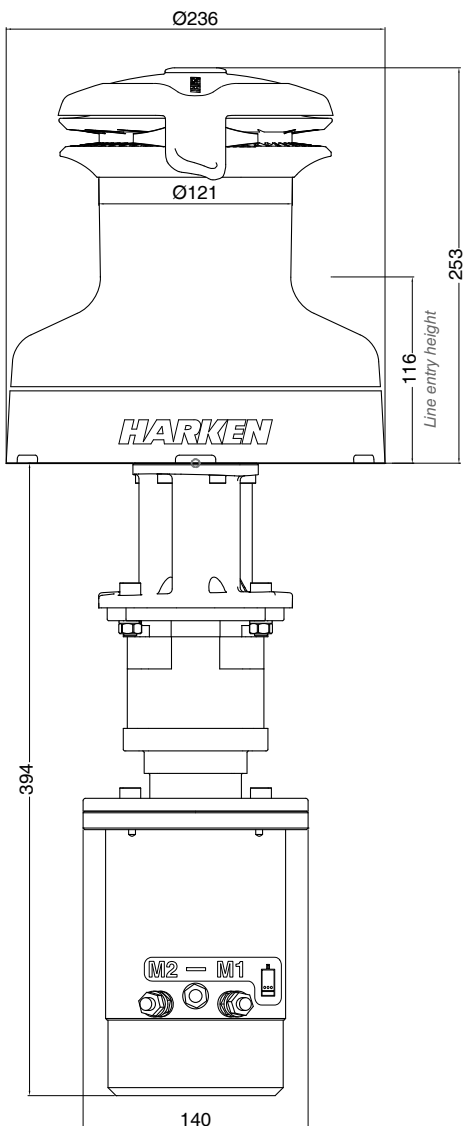

Hydraulic motor

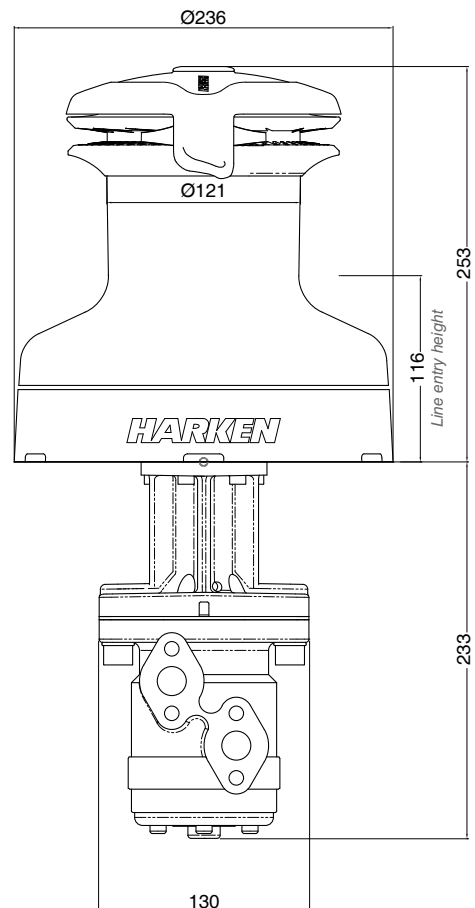

Installation

The winch must be installed on a flat area of the deck, reinforced if necessary to bear a load equal to at least twice the maximum working load of the winch.

It is the installer's responsibility to carry out all structural tests needed to ensure that the deck can bear the load.

Harken® does not supply the screws needed to install the winch since these may vary depending on the deck on which it is to be installed.

It is the installer's responsibility to choose the correct screws taking account of the loads they will have to bear.

Harken® assumes no responsibility for incorrect installation of its winches or for an incorrect choice of mounting screws.



DANGER!

Incorrect installation of the winch may cause severe injury or death. Consult the yard that built the boat in the case of doubt over the correct positioning of the winch.



WARNING!

Failure to use the correct number and type of mounting fasteners or failure to ensure the correct deck strength can result in the winch pulling off the deck suddenly and unexpectedly during high loads causing severe injury or death.



WARNING!

Verify the entry angle of the sheet. This must be 8° with tolerance of $\pm 2^\circ$, to avoid sheet overrides and damaging the winch or making the winch inoperable leading to loss of control of the boat which can lead to severe injury or death.



WARNING!

Mount the winch on the deck so that the drive gear is positioned where the sheet enters the winch drum.

Incorrect position of drive gear can weaken winch leading to failure which can cause an accident leading to severe injury or death.

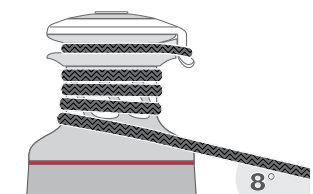

Once you have chosen the correct mounting position for the winch on the deck proceed with installation.

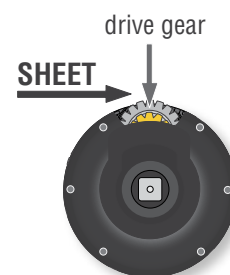

After correctly positioning the final drive gear with respect to the load, check that the motor, gearing, electrical wiring and/or hydraulic pipes can be housed below decks. To help find the optimal compromise, remember that, to make the installation of the motor easier, it can be coupled to the winch in different positions.

Once you have decided the correct mounting position for the winch on the deck and checked the space available below deck, proceed with the installation.

Installation procedure

To install the winch, remove the drum and use Socket Head (SH) bolts.

Tools needed  One medium flat-bladed screwdriver

To identify the various parts, refer to the exploded view at the end of this Manual.

 Torque to apply when assembling



1. Pull out the disconnect rod n°37



2. Unscrew the central screw ( 2Nm/18 in-lb)



3. Slide off the assy socket n°29 and the cover n°28



4. Unscrew the three screws n°27 ( 4Nm/35 in-lb)



5. Remove the self-tailing arm n°26 by rotating and lifting it.



6. Lift off the drum n°23

Install the winch on the deck in the position you have chosen, keeping in mind the limits described on page 4 and using socket head (SH) bolts.

Follow steps below only to install the winch using hexagonal headed bolts



7. Remove the stripper arm housing n°21



8. Slide out the assy clutch n°36



9. Slide out the central shaft n°19



10. Unscrew the 6 hex screws n°17
(\approx 20Nm/177 in-lb)



11. Remove the drum support n°16

Install the winch on the deck in the position you have chosen, keeping in mind the limits described on page 4 and using hexagonal headed (HH) M8 bolts.

Winch installation procedure

Carry out Installation procedure then install the winch on the deck in the chosen position

A. Position the base of the winch on the deck and mark the position of the holes or use the drilling cut-out template at the point where you have decided to place the winch.

Below is a reduced scale diagram.

The drilling cut out template is available on the Harken® website, www.harken.com

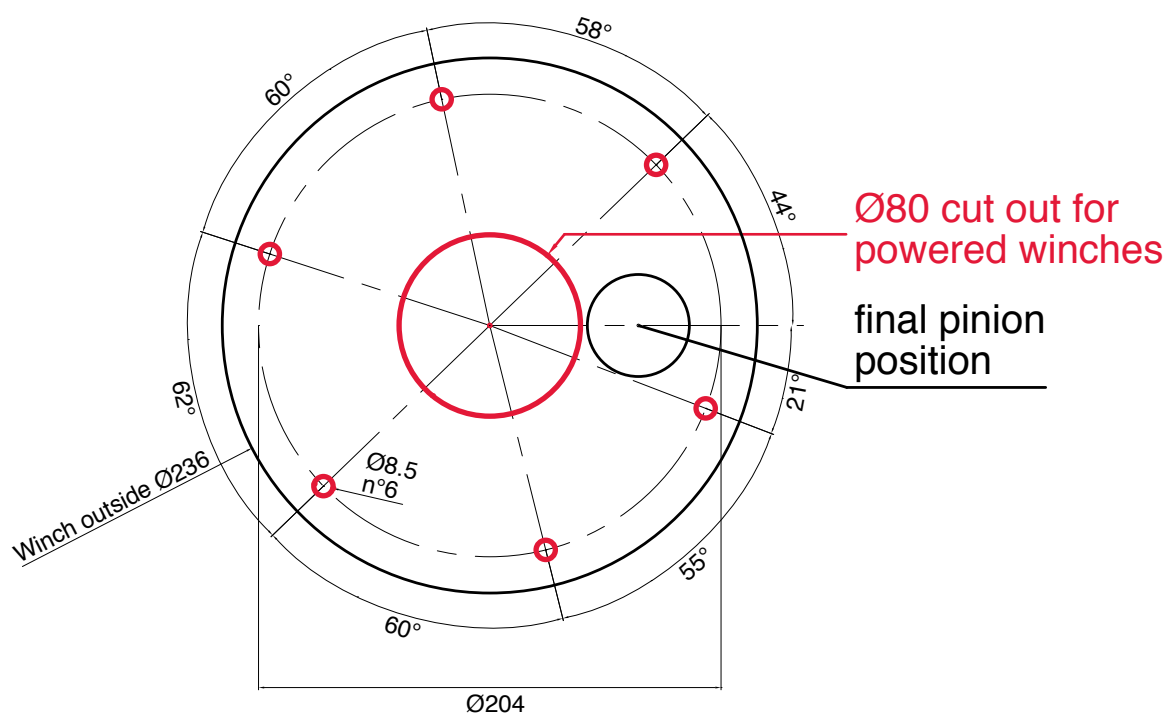

B. Remove the winch and drill the six 8.5 mm diameter holes.

C. Bolt the base of the winch to the deck using five M8 Socket Head (SH) bolts (no supplied by Harken®), correctly chosen for the thickness and type of the boat deck. Consult the yard that built the boat in case of doubt.



WARNING!

To install the winch on the deck, use only bolts in A4 stainless steel (DIN 267 part11). Bolts made of other materials may not have sufficient strength or may corrode which can result in winch pulling off deck suddenly and unexpectedly during high loads causing severe injury or death.

NOTICE

To mount winches on the deck, do not use countersunk bolts.

D. Fill the mounting holes with a suitable marine sealant.

E. Remove the excess adhesive/sealant from the holes and base drainage channels

F. Reassemble the winch following the steps in Installation procedure (page 7) in the reverse order, and apply the products indicated in the section on maintenance.

NOTICE

Before closing the winch, make sure the holes and drainage channels in the base of the winch are not obstructed.

Positioning the self-tailing arm





Position the self-tailing arm so that the line leaving the winch is led into the cockpit.

Motor installation procedure**WARNING!**

Make sure that the power is switched off before installing or carrying out maintenance on the winch.

Once you have installed the winch on the deck, proceed with motor installation. The motor can be coupled to the winch in different positions. Check the space available below deck and choose the suitable position.

Tools needed

-  A number five hex key
-  A number six hex key (only for vertical electric motor)
-  A number ten hex key (only for hydraulic motor)
-  Two number thirteen wrenches



1. Position the flange (see Page 10)



2. Tighten six M6 precote coated screws (8 Nm/ 71 in-lb)



3. Position the reduction gear and motor



4. Tighten the two screws (8 Nm/ 71in-lb). Be sure to align the flange.

NOTICE

Before positioning the flange, check to make sure that seals (the first one is above the flange and the second one is under the flange) are seated correctly.



After winch is assembled and before sailing, test the powered winch functioning: insert the lock-in winch handle in the handle socket and check that the disconnect rod must disconnect gearbox.

Electric equipment

To guarantee greater efficiency in terms of safety and long life, for every winch model is mandatory to install the Dual Function Control Box.

To fasten the Dual Function Control Box containing solenoids to bulkhead or wall, for all installation details and for all electric wiring schemes, refer to the Dual Function Control Box manual.



WARNING!

Before installing and using the device, read carefully the Dual Function Control Box manual available on web site www.harken.com

Refer to the following chart for wire size:

Total distance between winch and battery

Winch size	Current voltage	Under 16.4 ft AWG	Under 5 m mm ²	16.4 - 32.8 ft AWG	5 m - 10 m mm ²	32.8 - 49.2 ft AWG	10 m - 15 m mm ²	49.2 - 65.6 ft AGW	15m - 20 m mm ²
60.3	12 V	2	32	0	50	00	70	000	95
60.3	24 V	5	16	3	25	2	35	0	50

Refer to the following chart for HCP model:

Winch size	Current voltage	HCP model	Ampere rating
60.3	12 V	HCP1720	135A
60.3	24 V	HCP1717	80A

NOTICE

To connect motor, attach cable terminals to clamps between nut and lock nut. Hold nut in contact with motor using a spanner and tighten other nut with second spanner. Take special care not to turn the central spindles. These instructions apply when assembling and disassembling. We recommend using a torque wrench so as to obtain a torque equal to and no greater than 10 Nm (88 in-lb).

**NOTICE**

Note that correct electrical contact sequence is:
Nut – Cable Terminal – Self-Locking Washer – Lock Nut



Hydraulic connections diagram

The hydraulic motor must be connected to a hydraulic system using two high-pressure tubes which serve for input or output according to the direction in which the motor will be run. The motor also needs a third connection with a low pressure tube for drainage, so that excess oil can return to the main tank to avoid shortening the life of the motor. This motor uses an open centre valve.

Refer to the following chart for the hydraulic system:

For the hydraulic motor:

Input/output pipe thread: G 1/2 – depth 15 mm

Drainage pipe thread: G 1/4 – depth 12 mm

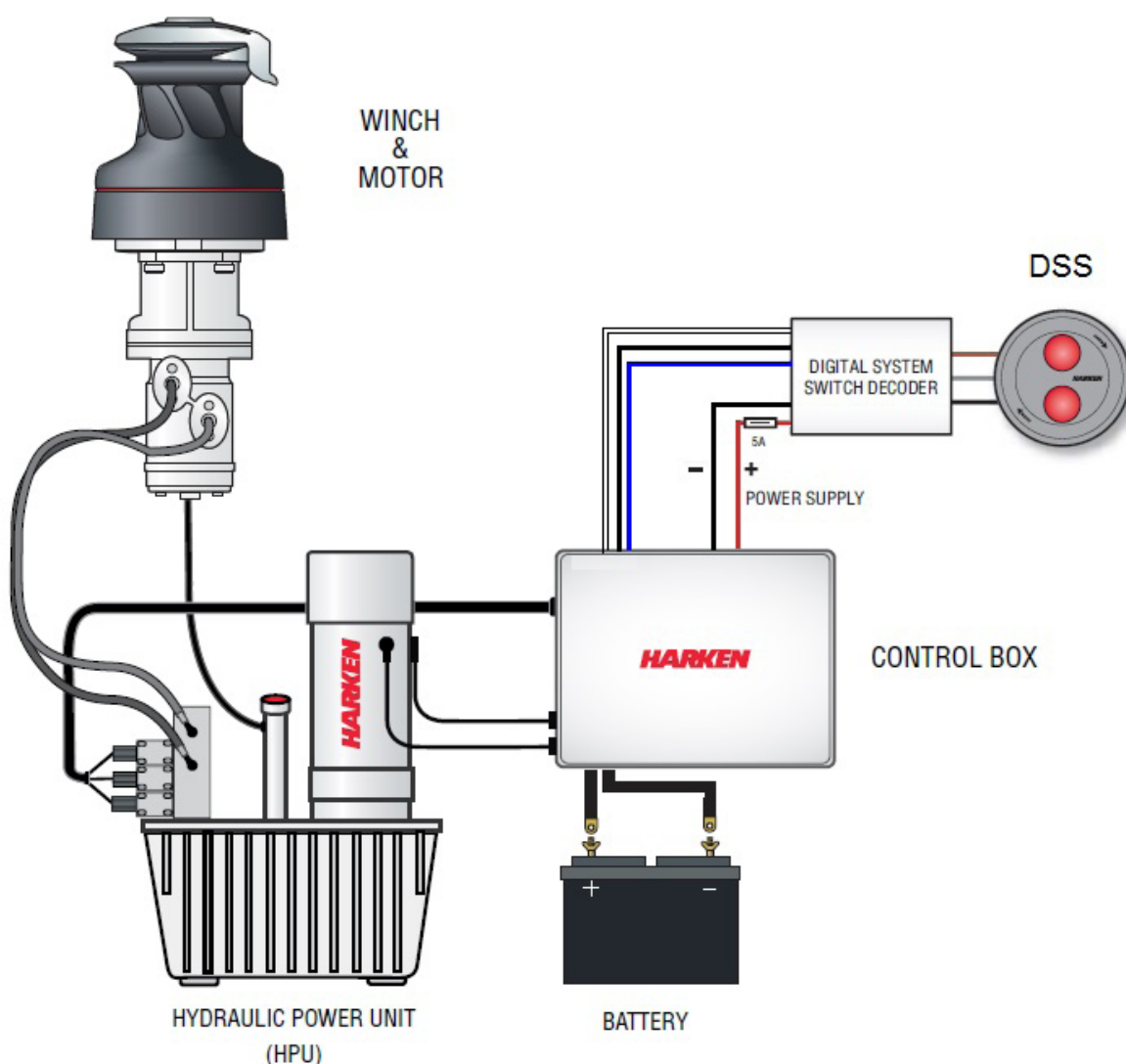

WARNING!

Refer to the Hydraulic Power Unit and Control Box manual.



WARNING!

Refer to the Digital System Switch manual.

Maintenance

Washing

Winches must be washed frequently with fresh water, and in any case after each use.

Do not allow teak cleaning products or other cleaners containing caustic solutions to come into contact with winches and especially anodised, chrome plated or plastic parts.

Do not use solvents, polishes or abrasive pastes on the logos, on the stickers on the winches or on any anodized, chrome plated and plastic surfaces.

Make sure that the holes and drainage channels in the base of the winch are not obstructed so that water does not collect.

Maintenance table

Winches must be visually inspected at the beginning and end of every season of sailing or racing. In addition they must be completely overhauled, cleaned and lubricated at least every 12 months. After an inspection, replace worn or damaged components. Do not replace or modify any part of the winch with a part that is not original.



WARNING!

Periodic maintenance must be carried out regularly. Lack of adequate maintenance shortens the life of the winch, can cause serious injury and also invalidate the winch warranty. Installation and maintenance of winches must be carried out exclusively by specialized personnel.

In the case of doubt contact Harken® Tech Service at techservice@harken.it



WARNING!

Make sure that the power is switched off before installing or carrying out maintenance on the winch.

Winch disassembly procedure

Tools needed

 *One medium flat-bladed screwdriver*

 *A number five hex key*

 *Brush*

 *Rags*

To identify the various parts refer to the exploded view at the end of this Manual.

 Torque to be applied in assembly phase

Carry out **Installation procedure** (page 7) as shown in the paragraph on winch installation and then do the following:



7. Remove the stripper arm housing n°21



8. Slide out the assy clutch n°36



9. Slide out the central shaft n°19



10. Unscrew the 6 hex screws n°17
($\approx 20\text{Nm}/177\text{ in-lb}$)



11. Slide out the drum support n°16



12. Remove the gear n°30, pawls carrier n°32, the bearings n°33 and 35 and the pin n°34
Important: washer n°7 may remain inside the drum support!



13. Remove the gear n°6, pawls carrier n°3 and the washer n°7



14. Remove the idler and pinion n°14



15. Remove the pawl carrier n°11



16. Remove gear n°10



17. Remove the gear n°2



18. Remove the roller bearing n°12



18. Remove roller bearings n°15



I. Unscrew the 4 screws n°25
(\approx 4Nm/35 in-lb)



II. Remove the jaws n°22

If it is necessary to replace any jaws of the winch, proceed as follows:
Inspect balls inside the drum and carefully check the correct position; if it is necessary to put back any balls, push balls in the race (as shown below):



Once the winch is completely disassembled, clean the parts with a degreasing that does not leave residues, proper to clean metal components; rinse plastic parts in fresh water. Once you have done this, dry the parts with cloths that do not leave residue.

Inspect gears, bearings, pins and pawls for any signs of wear or corrosion.

Carefully check the teeth of gears and ring gears to make sure there are no traces of wear.

Check the roller bearings and check there are no breaks in the bearing cages.

Replace worn or damaged components.

Carry out maintenance on components using the products listed below.

For more information on which products to use where, refer to the exploded diagram below.

Use a brush to lightly lubricate all gears, gear pins, teeth and all moving parts with grease.

Lightly lubricate the pawls and springs with oil. Do not use grease on the pawls!

Exploded view with maintenance products

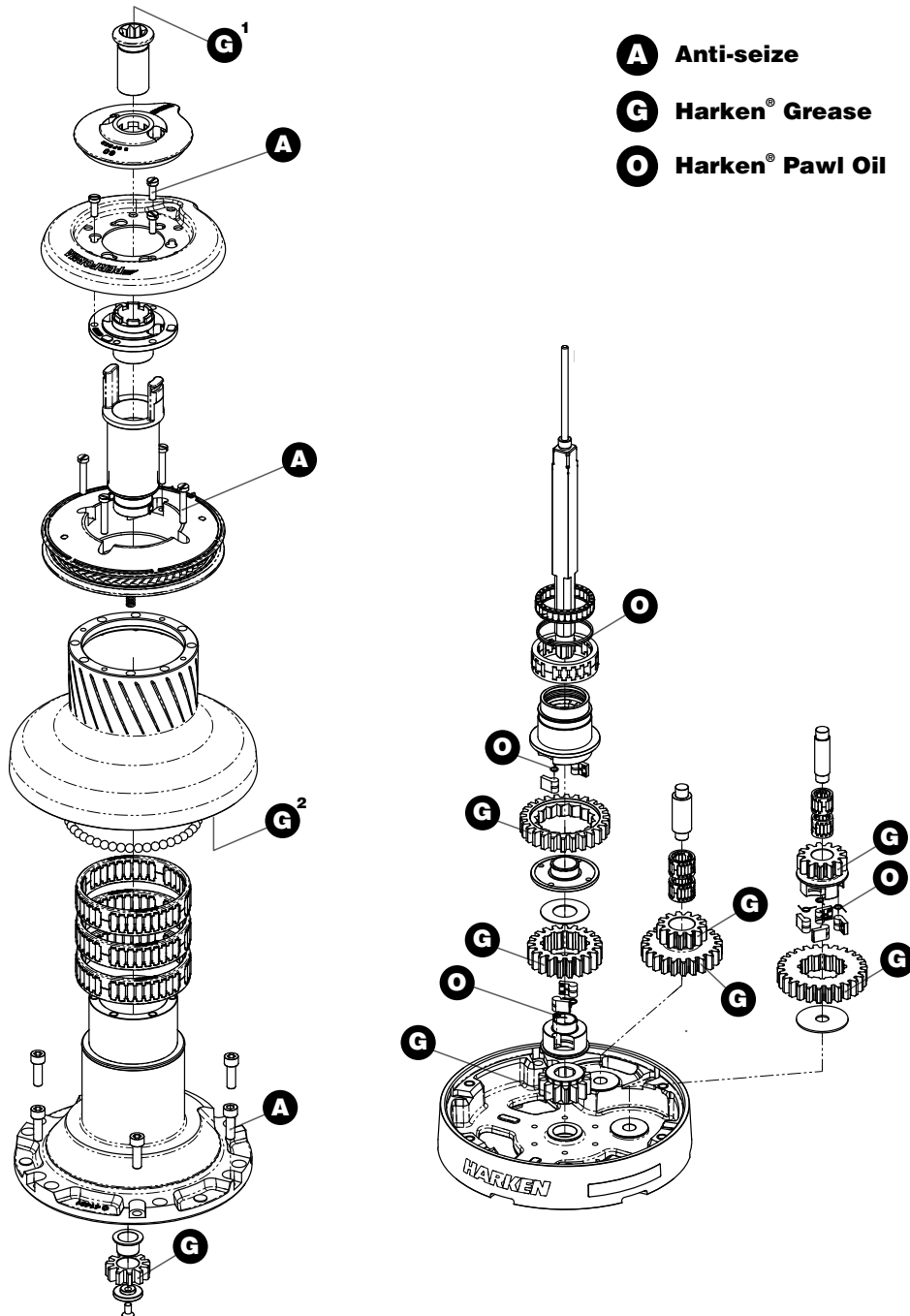

Apply Harken® grease where indicated above
 Apply Harken® grease: 1. on assy socket screw - 2. on drum gear

NOTICE

On every gear and every component that must be greased, apply Harken® grease with a brush in a proper quantity as shown below:



NOTICE

Harken® grease to apply on all teeth: do not use excessive quantity of product to void wastes. If in contact with the pawls, an excess of grease can compromise the safety of the winch.

Assembly

Make sure that the holes and drainage channels in the base of the winch are not obstructed. Assemble the winch in the reverse order of the sequence in the section on disassembly.

To tighten bolts, use the torque indicated in the disassembly procedure.



When positioning the stripper arm, align the peeler with it. If the jaws have been disassembled, insert peeler between the two jaws, taking care that the letters TOP on the peeler are facing upwards.



The icon ▲ on the Stripper Arm Housing indicates the Stripper Arm final position. Change the Stripper Arm Housing angle to modify the Stripper Arm final position.

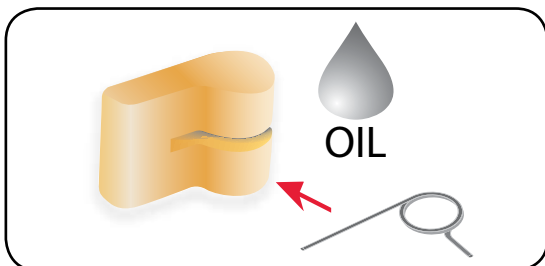

To assemble the pawls

Correctly position the spring in its housing as shown at left. Hold the spring closed and slide the pawl into its housing. Once in position, check that the pawls can be easily opened and closed with a finger.

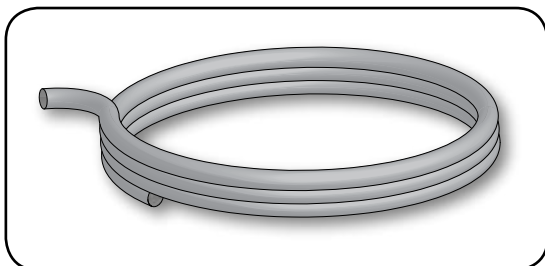

To assemble the clutch pin

Mount the spring with the pin pointing upwards so that it is wound in an anti-clockwise direction starting from the pin.

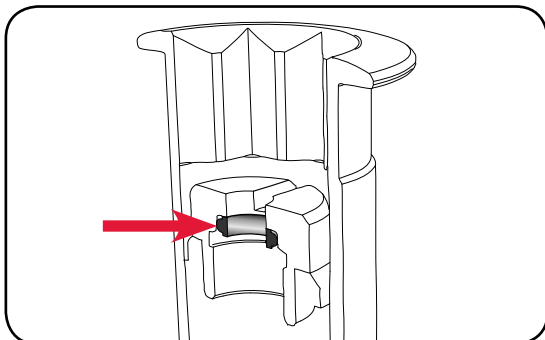

NOTICE

Before screw the central screw, check the correct position of the o-ring in the assy socket and apply Harken® grease.

In case of doubt concerning the assembly procedure contact Harken® Tech Service: techservice@harken.it

Harken® limited worldwide warranty

Refer to the Harken® Limited Worldwide Warranty in the Harken® Catalogue and on the website www.harken.com

Ordering spare parts

Spare parts can be requested from Harken® as described in the Harken® Limited Worldwide Warranty, indicating the part number in the Parts List and including the serial number of the winch for which the parts are required.

The serial number of the winch is printed on a plate on the drum support of the winch.



Manufacturer

Harken® Italy S.p.A.

Via Marco Biagi, 14
22070 Limido Comasco (CO) Italy
Tel: (+39) 031.3523511
Fax: (+39) 031.3520031
Email: info@harken.it
Web: www.harken.com

- **Tech Service**
Email: techservice@harken.it
- **Customer Service**
Tel: (+39) 031.3523511
Email: info@harken.it

Headquarters

Harken®, Inc.

1251 East Wisconsin Avenue
Pewaukee, Wisconsin 53072-3755 USA
Tel: (262) 691.3320
Fax: (262) 691.3008
Email: harken@harken.com
Web: www.harken.com

- **Tech Service**
Email: technicalservice@harken.com
- **Customer Service**
Tel: (262) 691-3320
Email: customerservice@harken.com

Performa Winch 60.3 STP EL/HY

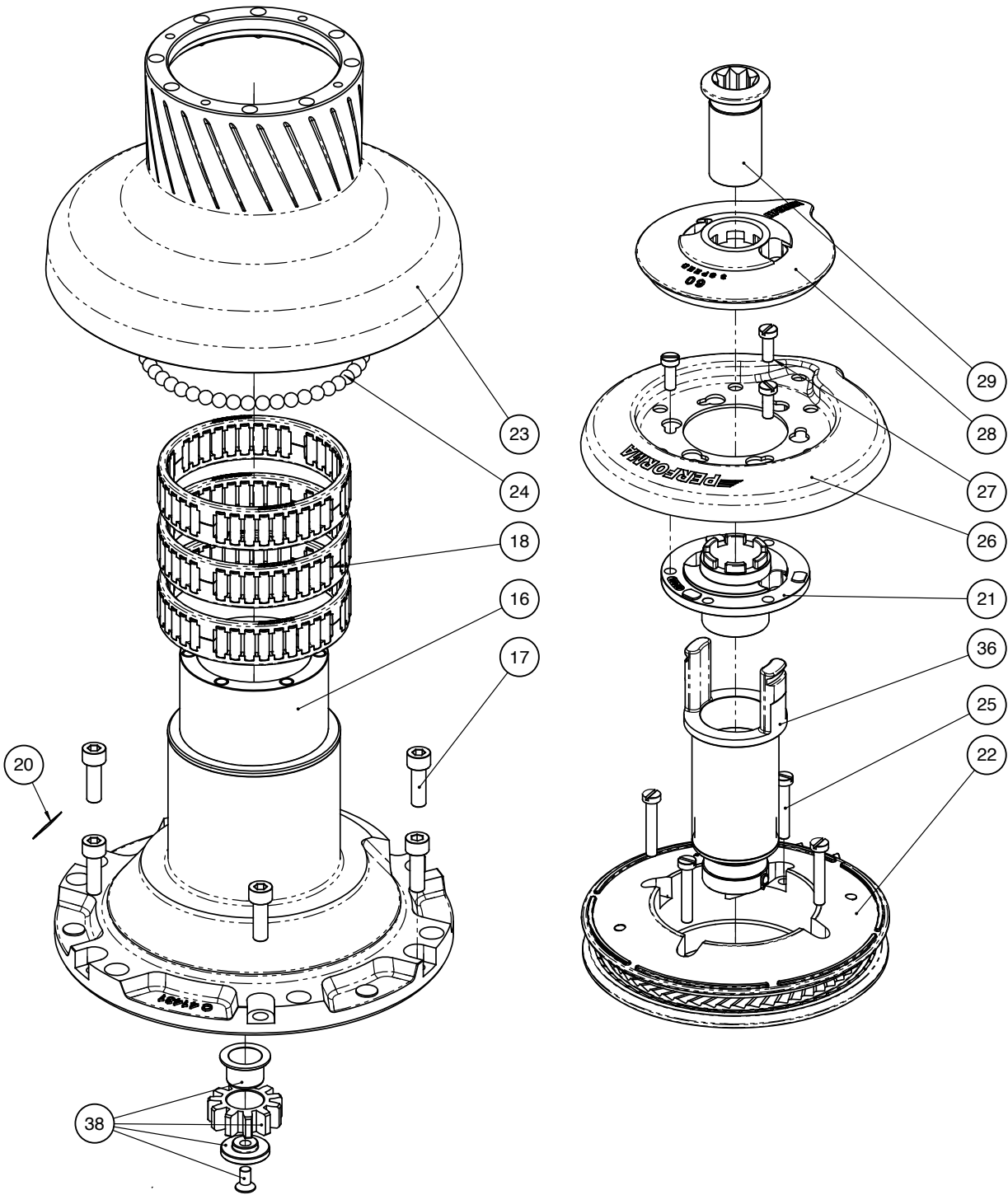

Performa Winch 60.3 STP EL/HY

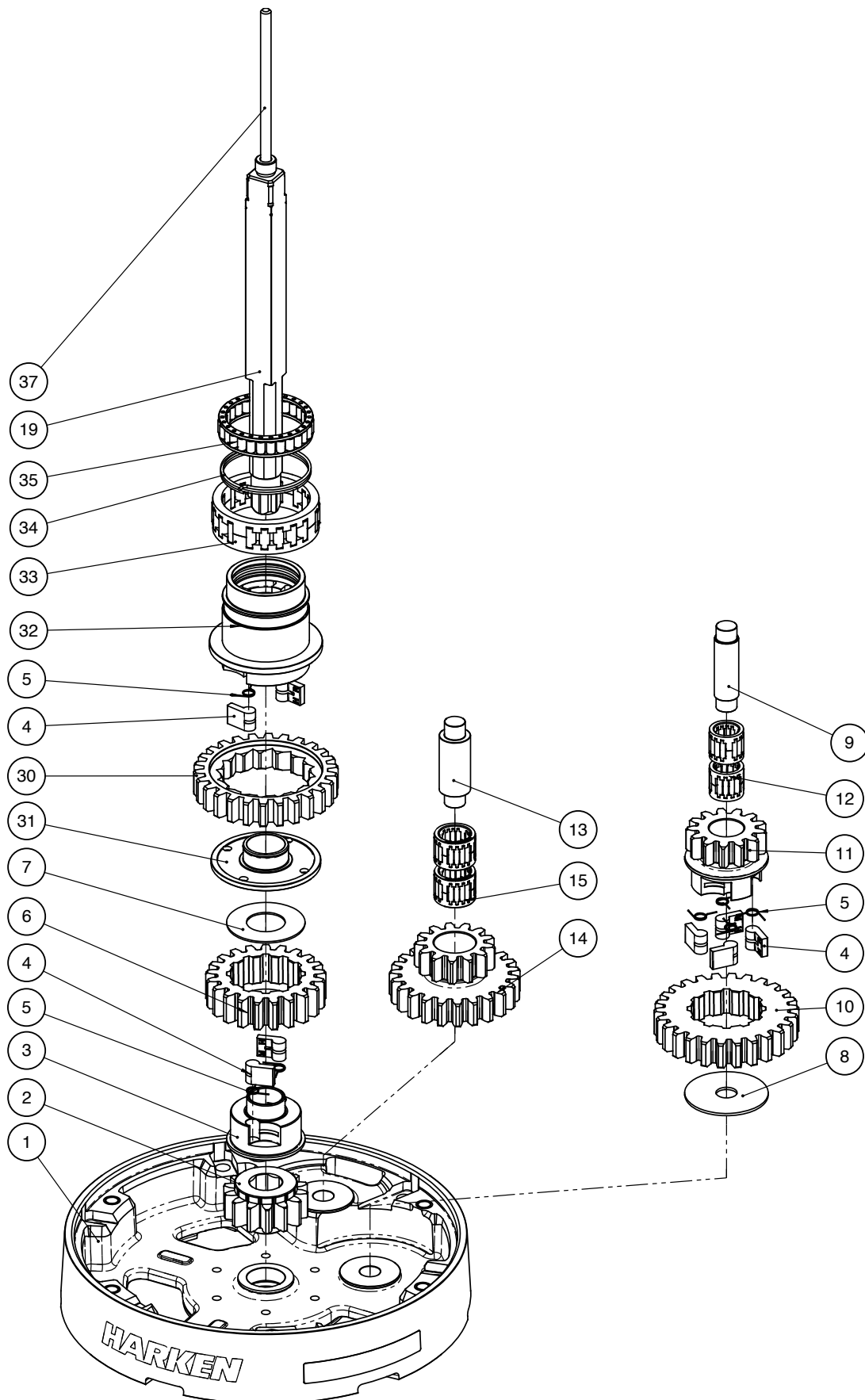

Performa Winch 60.3 STP EL/HY

Pos	Q.ty	Code	Description	Pos	Q.ty	Code	Description
1	1	A96574500	Performa Assy Base W60 EL/HY	22	1	A96555900	Performa Assy Jaws W60
	1	S476030004	W60 Performa Base				Lower Jaw W60
	1	S4130900A7	Centering bushing Ø12		1	S414850080	Upper Jaw W60
	2	S415580085	Bushing Ø22xØ25x8.5		4	S018520001	Peeler W60 - 70
			Bushing Ø12xØ35x9				Spring
			Winch Product Sticker**	23	1	A76537501	Performa Drum Assembly W60
2	1	S414400004	Gear Z14 W60	24	47	M0610280	Ball 5/16"
3	1	S413030004	Pawls Carrier Ø8xN2	25	4	M0601803	Screw UNI EN ISO 1207 - M6x35 - A4
4	8	S000090004	Racing pawl Ø8*	26	1	S657410019	Performa Black Stripper Arm W60
5	8	S000380001	Pawl Spring Ø8*	27	3	M0601903	Screw M6x16 UNI1207
6	1	S414390041	Ratchet Gear Z21xN2	28	1	S4167500B1	Cover 3 Speed W60
7	1	S413120002	Washer Ø22.5xØ45x1	29	1	A94191400	Assy Socket Handle Winch 3speed EL/HY
8	1	S278170002	Washer Ø12.5xØ48x1.5				Socket Handle 3 speed
9	1	S281010004	Pin for gear		1	S414940085	Washer Ø25xØ15x4
10	1	S414420041	Ratchet Gear Z26xN4		1	S414930003	Nut Screw for Disconnect Rod
11	1	S414410004	Pawls Carrier Gear Z13 N4		1	M0679797	O ring RC 2025 series
12	2	A72821800	Roller Bearing Ø14xØ20x18	30	1	S280870041	Gear IV
13	1	S416030004	Gear Pin Ø12xØ18x52,5	31	1	S414580081	Shim Bushing 3 speed
14	1	S414480004	Idler and Pinion Z23/Z13 W60	32	1	S415400004	Pawls Carrier 3 speed
15	2	A74162300	Roll bearing Ø24xØ18x18	33	1	A73129200	Roller bearing Ø50xØ62x20
16	1	A94190800	Assy Housing Winch 60.3	34	1	S377510001	Clutch Spring
			Housing W60	35	1	A73422600	Bearing Ø45xØ55x12
	2	S415580085	Bushing Ø12xØ35x9	36	1	A94158000	Assy Clutch 3rd speed W60
	1	S415810081	Bushing				Assy Command tube W60
17	6	M0606303	Screw M8x25 UNI 5931		1	S415420004	Dog Clutch 3 speed
18	3	A74145000	Roller Bearing Ø95xØ107x26		2	M6009463	Spring loaded ball plunger Ø6
19	1	A96753600	Assy Central Shaft Winch 60 EL/HY	37	1	S419020002	Disconnect rod W60.3
			Central Shaft Pred. W60	38	1	A94145300	Assy Gear 3rd speed
	1	S413880002	Washer Ø17.2xØ32x1.5		1	S414530004	Idler Gear 3 speed
20			Winch Serial Number Sticker		1	S414550081	Bushing Ø22xØ25x15.5
21	1	S4155700A0	Stripper arm support		1	S414540080	Washer 3 speed
					1	M0604003	Screw M6x12 UNI 5933

*Available with service kit; see website www.harken.com

**Winch product sticker



Horizontal electric motor

TOP VIEW

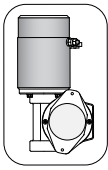

* **Motor installed in right-hand configuration.**

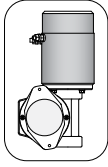

** **Motor installed in left-hand configuration.**

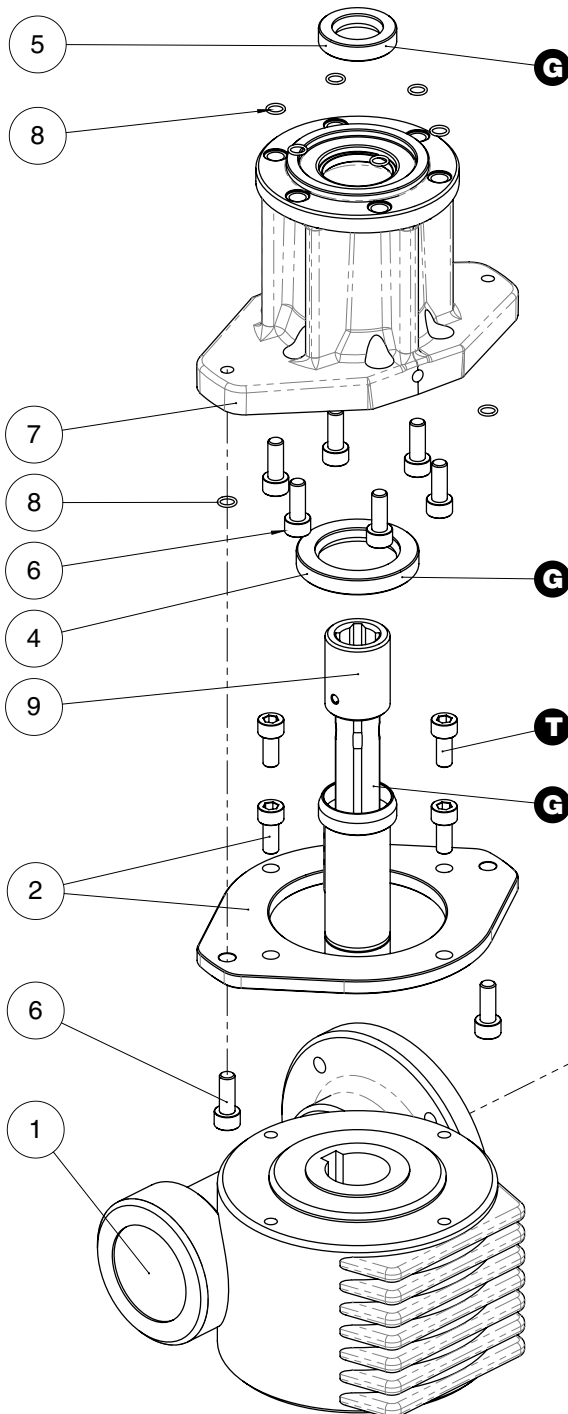

Pos	Q.ty	Code	Description
1	1	A93127900	KIT Gear Reduction 1/24
	1	A94194900	KIT LM Gear Reduction 1/24
2	1	A94149200	KIT Assy Electric Motor Flange
	1	A94149200L	KIT Assy Electric Motor Flange Left
	4	M0606803	Electric Motor Flange Screw M6x14 UNI 5931
3	1	A96010700	KIT EL Motor 12V 1,5kW
	1	A96010600	KIT EL Motor 24V 2kW
			Electric Motor Polarity motor sticker Screw stud M6x26 Washer Ø6 Nut M6 UNI5588
	1	M6014206	Key DIN 6885 5x5x15
4	1	M0612097	Sealer Ø30xØ47x7
5	1	M6007297	Lip seal Ø17xØ30x7
6	8	S415360003	Screw M6x16 UNI EN ISO 5931:2003 precote coating
7	1	S496650053	Horizontal Motorgear Flange
8	8	M6015697	O-Ring Seal ORM 0055-10 (Ø5,5 x Ø1)
9	1	A96589000	Performa KIT EL HO Motor Clutch
			Shaft Motorgear HO Performa HO Gear Motor Shaft Hub GearMotor
	1	M0601402	Dowel UNI EN ISO 8752:2000- Ø4x24
	1	M6020097	O-ring 19.1x1.6
	1	S418620001	Disconnect spring
	1	S414050080	Flange GearMotor Shaft HO
1	M6010303	Key 8x5x40 UNI 7511	

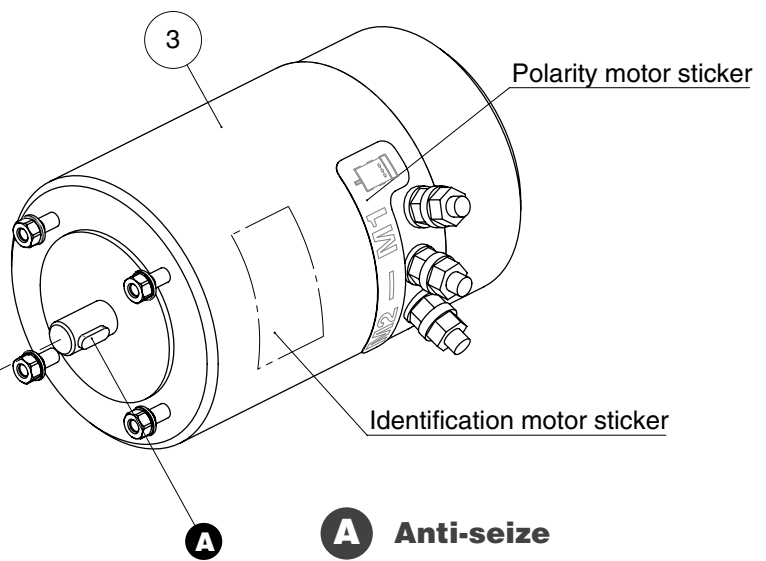

- A** Anti-seize
- G** Harken® Grease
- T** Axial Threadlocker

Vertical electric motor

Pos	Q.ty	Code	Description	Pos	Q.ty	Code	Description
1	1	A96010500	KIT EL Motor 12V 1,5kW VT	3	1	A94150500	KIT EL VT Motor Flange <i>Vertical Motorgear Flange</i>
	1	A96010400	KIT EL Motor 24V 2kW VT <i>Electric Motor</i>		4	M0602903	NUT M8 - UNI 5588 - A4
			<i>Polarity motor sticker</i>		4	M0603103	WASHER 8.4 U1751 DIN127 A4
			<i>Screw M8x20 UNI5931</i>		1	M6007297	Lip seal Ø17xØ30x7
	1	M6014206	Key DIN 6885 5x5x15	6	M6015697	O-Ring Seal ORM 0055-10 (Ø5,5 x Ø1)	
2	1	A96562900	Vertical reduction gear box 1/21.3	6	S415360003	Screw M6x16 UNI EN ISO 5931:2003 <i>precote coating</i>	
				4	M0606303	Screw M8x25 UNI 5931	
				4	1	A94193700	KIT EL VT Motor Clutch <i>Connecting Coupling Ø31.5</i>
							<i>Toothed coupling</i>
				1	M0620401	Spring pin 5x40 DIN1481	
				1	S326490001	Spring	
				1	S415040080	Bushing	
				1	S329360082	Washer	
				1	M0666603	Screw M6x16 UNI 5933	

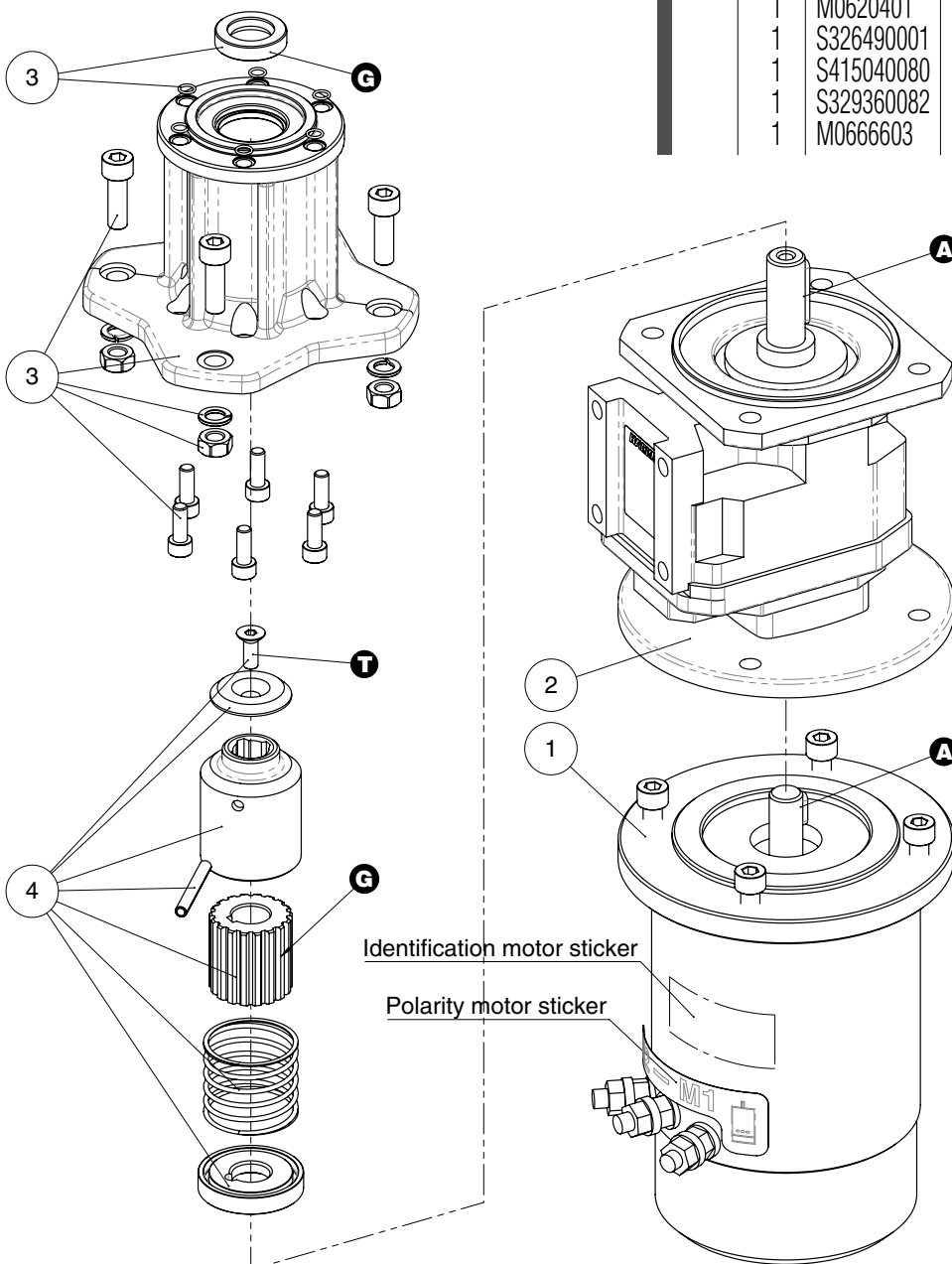

- A** Anti-seize
- G** Harken® Grease
- T** Axial Threadlocker

Hydraulic motor

Pos	Q.ty	Code	Description	Pos	Q.ty	Code	Description
1	1	G045942000Y	Hydraulic motor W46-60	4	1	A94149100	KIT HY Motor Flange W46-70
2	1	S415000080	Hydraulic Motor Spacer	6	1	S415360003	Hydraulic Motorgear Flange Screw M6x16 UNI EN ISO 5931:2003 precote coating
3	1	A94193200	KIT Clutch HY Motor W46-70	6	1	M6015697	O-Ring Seal ORM 0055-10 (Ø5,5 x Ø1)
			Toothed coupling	1	1	M6007297	Lip seal Ø17xØ30x7
			Connecting Coupling Ø31.5	2	1	M0621503	Washer D.13 U1751 DIN127
	1	M0620401	Spring pin 5x40 DIN1481	2	1	M0667103	Screw M12x35 UNI5931
	1	S415010080	Bushing				
	1	S326490001	Spring				
	1	S329360082	Washer				
	1	M0635303	Screw M8x16 UNI6109				

