

Installation and Maintenance Manual

MRW-G

Radial Winch 70.2 ST

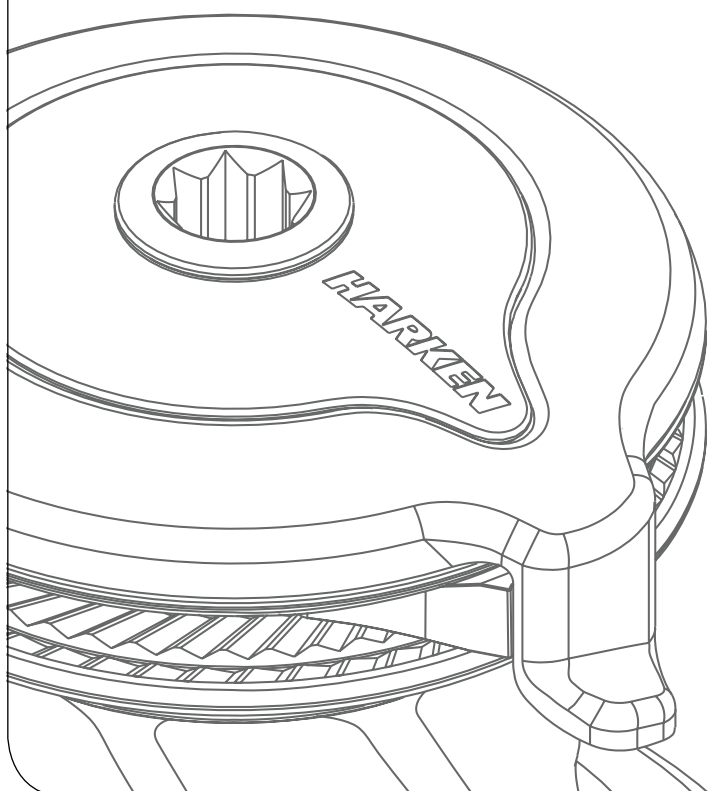

HARKEN[®]

Introduction	3
Technical characteristics	3
<i>Weights</i>	3
<i>Maximum working load</i>	3
Outline	3
Installation	4
<i>Installation Procedure</i>	5
<i>Positioning the self-tailing arm</i>	8
Maintenance	8
<i>Washing</i>	8
<i>Maintenance table</i>	8
<i>Disassembly procedure</i>	8
<i>Exploded view with maintenance products</i>	12
<i>Assembly</i>	13
Harken® limited worldwide warranty	14
Ordering spare parts	14
Exploded view	15
<i>Radial Winch 70.2 STA, STC, STCW</i>	15
Parts List	17
<i>Radial Winch 70.2 STA</i>	17
<i>Radial Winch 70.2 STC</i>	18
<i>Radial Winch 70.2 STCW</i>	19
Exploded view	20
<i>Radial Winch 70.2 STBBB, STCCC</i>	20
Parts List	22
<i>Radial Winch 70.2 STBBB</i>	22
<i>Radial Winch 70.2 STCCC</i>	23

Introduction

This manual gives technical information on winch installation and maintenance, including disassembling and reassembling.

This information is DESTINED EXCLUSIVELY for specialised personnel or expert users.

Installation, disassembling and reassembling of the winch by personnel who are not experts may cause serious damage to users and those in the vicinity of the winch.

Harken® accepts no responsibility for defective installation or reassembly of its winches.

In case of doubt the Harken® Tech Service is at your disposal at techservice@harken.it

This Manual is available only in English. If you do not fully understand the English language, do not carry out the operations described in this Manual.

Technical characteristics

	Power ratio	Gear ratio
1st speed	22,20 : 1	5,70 : 1
2nd speed	72,00 : 1	18,50 : 1

The theoretical power ratio does not take friction into account.

Weights

	ST A version	ST C/CW versions	ST BBB/CCC versions
Weight (Kg)	11,3	15,1	16,7

Versions: A = drum in anodised aluminium; C = drum in chrome bronze; CW = chrome/white;
BBB = all bronze; CCC = All-Chrome bronze

Maximum working load



WARNING!

The maximum working load (MWL) for the 70.2 ST Radial Winch is 2700 Kg (5952 lb)

Subjecting the winch to loads above the maximum working load can cause the winch to fail or pull off the deck suddenly and unexpectedly during high loads causing severe injury or death.

Outline

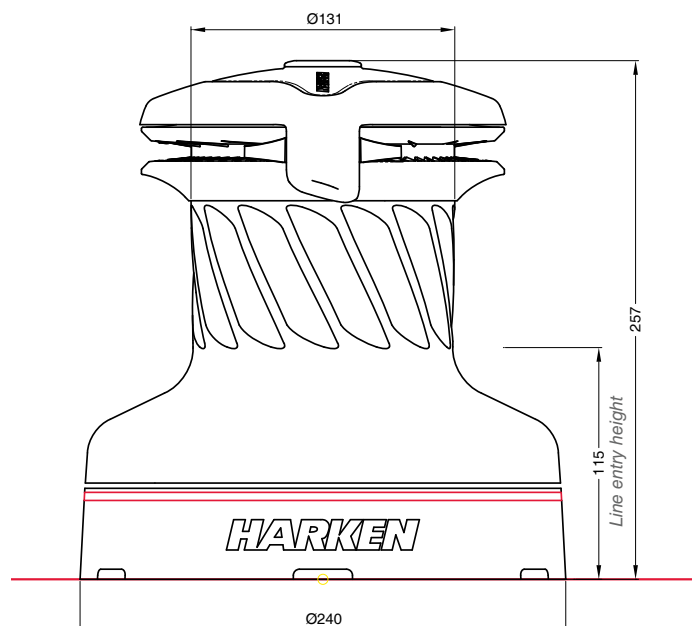

Installation

The winch must be installed on a flat area of the deck, reinforced if necessary to bear a load equal to at least twice the maximum working load of the winch.

It is the installer's responsibility to carry out all structural tests needed to ensure that the deck can bear the load.

Harken® does not supply the screws needed to install the winch since these may vary depending on the deck on which it is to be installed.

It is the installer's responsibility to choose the correct screws taking account of the loads they will have to bear.

Harken® assumes no responsibility for incorrect installation of its winches or for an incorrect choice of mounting screws.



DANGER!

Incorrect installation of the winch may cause severe injury or death. Consult the yard that built the boat in the case of doubt over the correct positioning of the winch.



WARNING!

Failure to use the correct number and type of mounting fasteners or failure to ensure the correct deck strength can result in the winch pulling off the deck suddenly and unexpectedly during high loads causing severe injury or death.



WARNING!

Verify the entry angle of the sheet. This must be 8° with tolerance of $\pm 2^\circ$, to avoid sheet overrides and damaging the winch or making the winch inoperable leading to loss of control of the boat which can lead to severe injury or death.

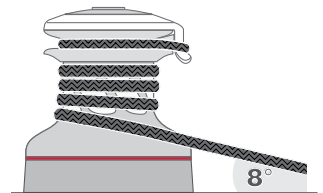

WARNING!

Mount the winch on the deck so that the drive gear is positioned where the sheet enters the winch drum.

Incorrect position of drive gear can weaken winch leading to failure which can cause an accident leading to severe injury or death.

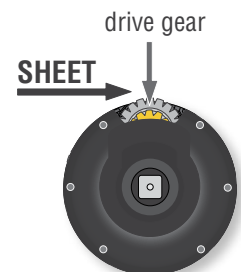

Once you have chosen the correct mounting position for the winch on the deck proceed with installation.

Installation Procedure

To install the winch you must remove the drum and use Socket Head (SH) bolts.

Tools needed:  One medium flat-bladed screwdriver

To identify the various parts, refer to the exploded view at the end of this Manual.

🔧 Torque to apply when assembling



1. Unscrew the central screw (🔧2Nm/18 in-lb)



2. Slide off the assy socket n°30 and the cover 29



3. Unscrew the three screws n°28
(🔧4Nm/35 in-lb)



4. Remove the self-tailing arm n°27 by rotating and lifting it.



5. Lift off the drum n°24

Install the winch on the deck in the position you have chosen, keeping in mind the limits described on page 4 and using socket head (SH) bolts.

Follow steps below only to install the winch using hexagonal headed bolts



6. Completely unscrew the three screws n° 28



7. Remove the stripper arm housing n°21



8. Slide out the central shaft n°19



9. Unscrew the 6 hex screws n°17
(\approx 20Nm/177 in-lb)



10. Remove the drum support n°16

Important: washer n°7 may remain inside the drum support!

Install the winch on the deck in the position you have chosen, keeping in mind the limits described on page 4 and using hexagonal headed (HH) M8 bolts.

Carry out Installation procedure then install the winch on the deck in the chosen position.

A. Position the base of the winch on the deck and mark the position of the holes or use the drilling cut-out template at the point where you have decided to place the winch.

Below is a reduced scale diagram.

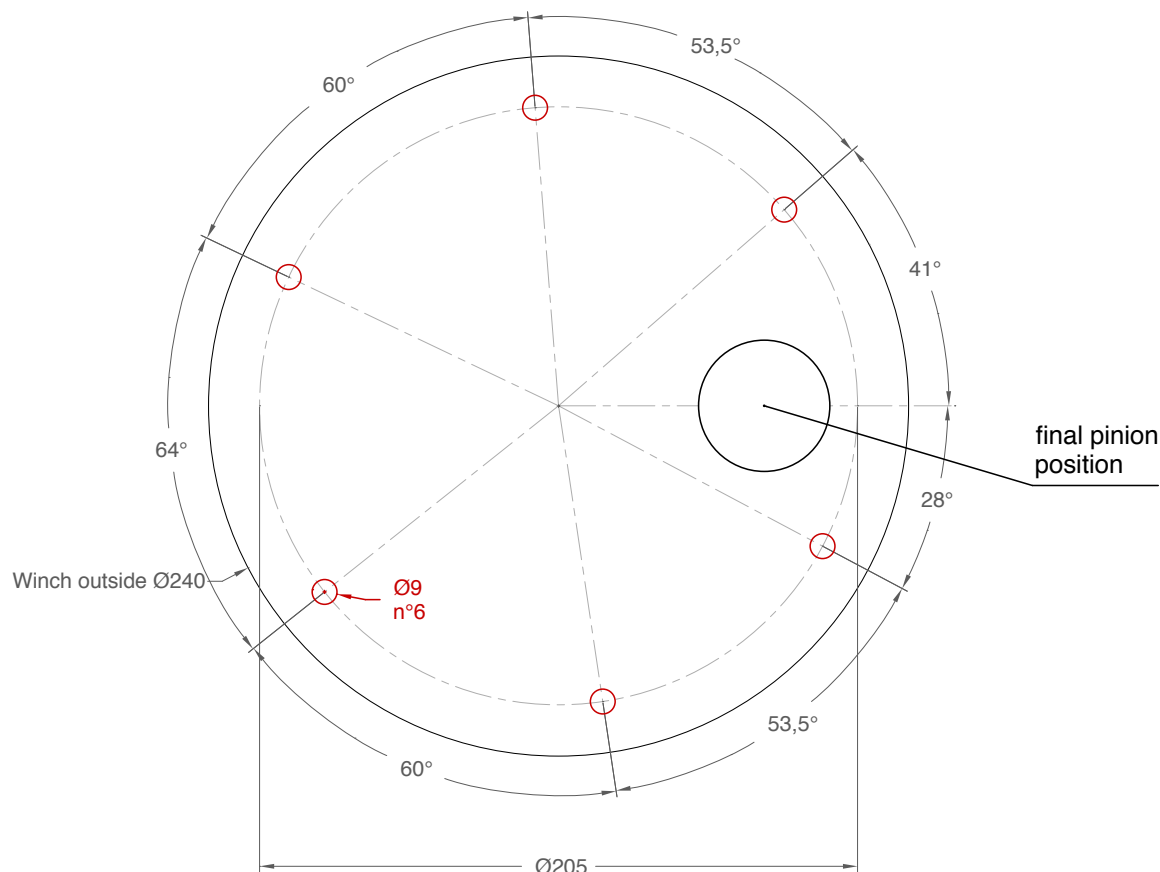

The drilling cut out template is available on the Harken® website, www.harken.com

B. Remove the winch and drill the six 8.5 mm diameter holes.

C. Bolt the base of the winch to the deck using six M8 bolts (not supplied by Harken®), correctly chosen for the thickness and type of the boat deck. Consult the yard that built the boat in case of doubt.



WARNING!

To install the winch on the deck, use only bolts in A4 stainless steel (DIN 267 part11). Bolts made of other materials may not have sufficient strength or may corrode which can result in winch pulling off deck suddenly and unexpectedly during high loads causing severe injury or death.

NOTICE

To mount winches on the deck, do not use countersunk bolts.

D. Fill the mounting holes with a suitable marine sealant.

E. Remove the excess adhesive/sealant from the holes and base drainage channels

F. Reassemble the winch following the steps in **Installation procedure** (page 5) in the reverse order, and apply the products indicated in the section on maintenance.

NOTICE

Before closing the winch, make sure the holes and drainage channels in the base of the winch are not obstructed.

Positioning the self-tailing arm

Position the self-tailing arm so that the line leaving the winch is led into the cockpit.

MaintenanceWashing

Winches must be washed frequently with fresh water, and in any case after each use. Do not allow teak cleaning products or other cleaners containing caustic solutions to come into contact with winches and especially anodised, chrome plated or plastic parts. Do not use solvents, polishes or abrasive pastes on the logos or stickers on the winches. Do not use polishes or abrasive pastes on anodised, chromed plated or plastics surfaces. Make sure that the holes and drainage channels in the base of the winch are not obstructed so that water does not collect.

Maintenance table

Winches must be visually inspected at the beginning and end of every season of sailing or racing. In addition they must be completely overhauled, cleaned and lubricated at least every 12 months. After an inspection, replace worn or damaged components. Do not replace or modify any part of the winch with a part that is not original.



**WARNING!**

Periodic maintenance must be carried out regularly. Lack of adequate maintenance shortens the life of the winch, can cause serious injury and also invalidate the winch warranty. Installation and maintenance of winches must be carried out exclusively by specialized personnel.

In the case of doubt contact Harken® Tech Service at techservice@harken.it

Disassembly procedure

Tools needed

-  One medium flat-bladed screwdriver
-  A number five hex key
- Rags

To identify the various parts refer to the exploded view at the end of this Manual.

 Torque to be applied in assembly phase

Carry out **Installation procedure** (page 5) as shown in the paragraph on winch installation and then do the following:



6. Completely unscrew the three screws n° 28



7. Remove the stripper arm housing n°21



8. Slide out the central shaft n°19



9. Unscrew the 6 hex screws n°17
($\approx 20\text{Nm}/177\text{ in-lb}$)



10. Remove the drum support n°16
Important: washer n°7 may remain inside the drum support!



11. Remove the gear n°6, pawls n°3 and the washer n°7



12. Remove the gear n°2



13. Remove the idler and pinion n°14



14. Remove roller bearings n°15



15. Remove the pawls n°11



16. Remove the gear n°10



17. Remove roller bearings n°12

If it is necessary to replace any **jaws** of the winch, proceed as follows:



I. Unscrew the 4 screws n°26
($\approx 4\text{Nm}/35\text{ in-lb}$)



II. Remove the jaws n°23

Inspect balls inside the drum and carefully check the correct position; if it is necessary to put back any balls, push balls in the race (as shown below):



Once the winch is completely disassembled, clean the parts with a degreasing that does not leave residues, proper to clean metal components; rinse plastic parts in fresh water. Once you have done this, dry the parts with cloths that do not leave residue.

Inspect gears, bearings, pins and pawls for any signs of wear or corrosion.

Carefully check the teeth of gears and ring gears to make sure there are no traces of wear.

Check the roller bearings and check there are no breaks in the bearing cages.

Replace worn or damaged components.

Carry out maintenance on components using the products listed below.

For more information on which products to use where, refer to the exploded diagram below.

Use a brush to lightly lubricate all gears, gear pins, teeth and all moving parts with grease.

Lightly lubricate the pawls and springs with oil. Do not use grease on the pawls!

Exploded view with maintenance products

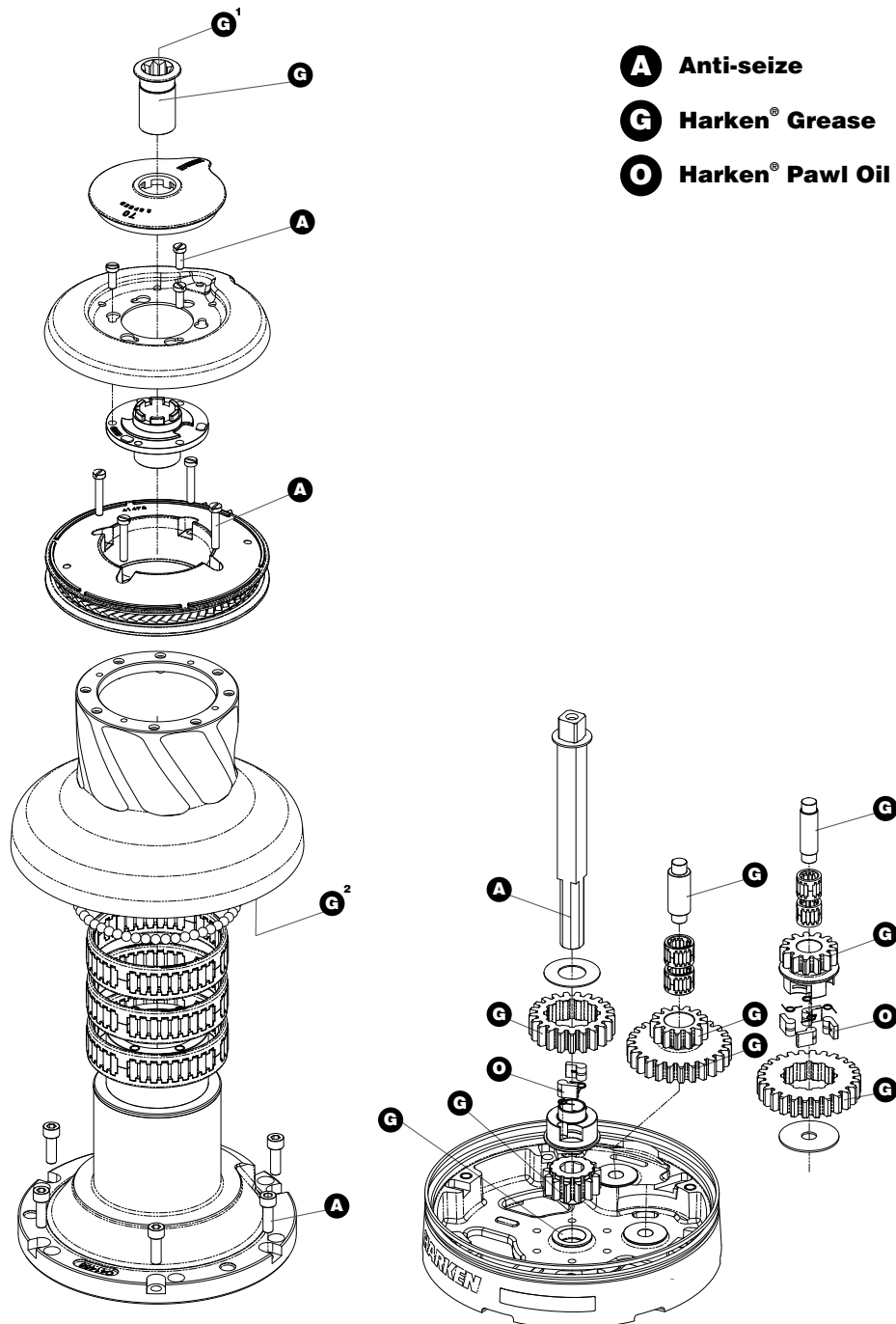

- A** Anti-seize
- G** Harken® Grease
- O** Harken® Pawl Oil

Apply Harken® grease where indicated above
 Apply Harken® grease: 1. on assy socket screw - 2. on drum gear

NOTICE

On every gear and every component that must be greased, apply Harken® grease with a brush in a proper quantity as shown below:



NOTICE

Harken® grease to apply on all teeth: do not use excessive quantity of product to void wastes. If in contact with the pawls, an excess of grease can compromise the safety of the winch.

Assembly

Make sure that the holes and drainage channels in the base of the winch are not obstructed
 Assemble the winch in the reverse order of the sequence in the section on disassembly.

To tighten bolts, use the torque indicated in the disassembly procedure.



The icon ▲ on the Stripper Arm Housing indicates the Stripper Arm final position.
 Change the Stripper Arm Housing angle to modify the Stripper Arm final position.



When positioning the stripper arm, align the peeler with it.
 If the jaws have been disassembled, insert peeler between the two jaws, taking care that the letters TOP on the peeler are facing upwards.

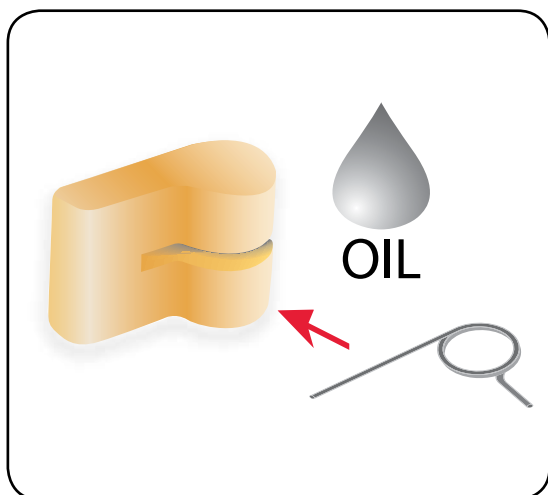

To assemble the pawls

Correctly position the spring in its housing as shown at left. Hold the spring closed and slide the pawl into its housing. Once in position, check that the pawls can be easily opened and closed with a finger.

In case of doubt concerning the assembly procedure contact Harken® Tech Service:
techservice@harken.it

Harken® limited worldwide warranty

Refer to the Harken® Limited Worldwide Warranty in the Harken® Catalogue and on the website www.harken.com

Ordering spare parts

Spare parts can be requested from Harken® as described in the Harken® Limited Worldwide Warranty, indicating the part number in the Parts List and including the serial number of the winch for which the parts are required.

The serial number of the winch is printed on a plate on the drum support of the winch.

**Manufacturer*****Harken® Italy S.p.A.***

Via Marco Biagi, 14
23570 Limido Comasco (CO) Italy
Tel: (+39) 031.3523511
Fax: (+39) 031.3535031
Email: info@harken.it
Web: www.harken.com

- **Tech Service**
Email: techservice@harken.it
- **Customer Service**
Tel: (+39) 031.3523511
Email: info@harken.it

Headquarters***Harken®, Inc.***

1251 East Wisconsin Avenue
Pewaukee, Wisconsin 53072-3755 USA
Tel: (262) 691.3335
Fax: (262) 691.3008
Email: harken@harken.com
Web: www.harken.com

- **Tech Service**
Email: technicalservice@harken.com
- **Customer Service**
Tel: (262) 691-3335
Email: customerservice@harken.com

Exploded view

Radial Winch 70.2 STA, STC, STCW

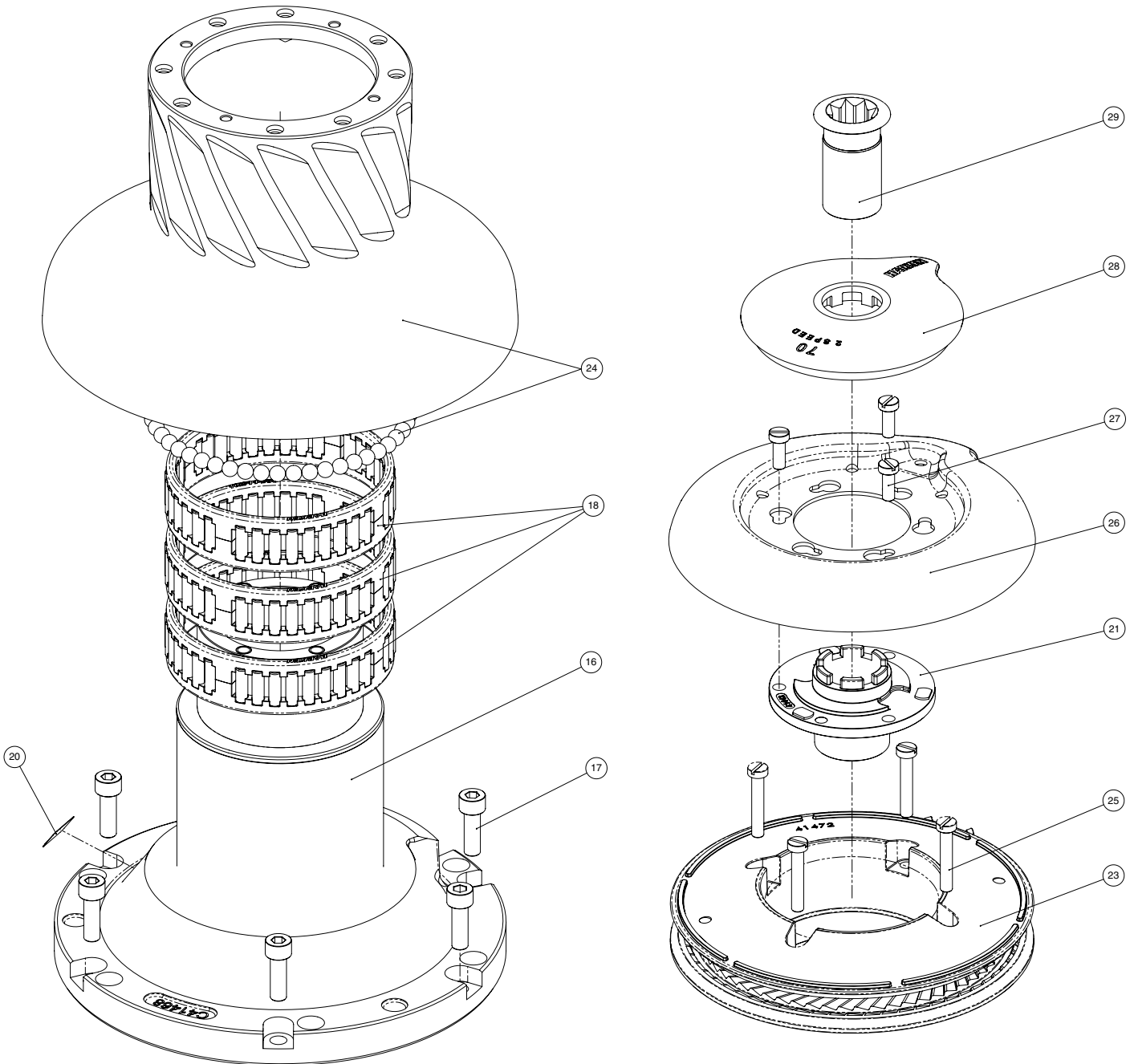

Parts List

Radial Winch 70.2 STA

A= drum in anodised aluminium

Pos.	Q.ty	Code	Description	Pos.	Q.ty	Code	Description
1	1	A94146700	Assy Base Winch 70 Base W70	19	1	A94147900	Assy Shaft Winch 70 Central shaft W70 ST
	1	S476030004	Centering bushing Ø12		1	S413880002	Washer Ø17.2xØ32x1.5
	1	S4152300A7	Bushing Ø22xØ25x9.5	20			Winch Serial Number Sticker
	2	S415580085	Bushing Ø12xØ35x9 Winch Product Sticker**	21	1	S4144300A0	Stripper Arm support W60/70
2	1	S414770004	Gear Z13 W70	22	1	S281700097	Red line
3	1	S413030004	Pawls Carrier Ø8xN2	23	1	A94147100	Assy Jaws winch 70 Lower Jaw W70 Upper Jaw W70 Peeler W60 - 70 SPRING
4	6	S000080003	Pawl Ø8*		1	S414850080	
5	6	S000380001	Pawl Spring Ø8*		4	S385970001	
6	1	S414390041	Ratchet Gear Z21xN2	24	1	A96966000	Drum spare kit Winch 70 Drum assembly Winch 70
7	1	S413120002	Washer Ø22.5xØ45x1		50	M0610280	Ball 5/16"
8	1	S278170002	Washer Ø12.5xØ48x1.5	25	4	M0601803	Screw UNI EN ISO 1207 - M6x35 - A4
9	1	S281010004	Pin for gear	26	1	S414730019	Stripper Arm W70
10	1	S414420041	Ratchet Gear Z26xN4	27	3	M0601903	Screw M6x16 UNI1207
11	1	S414410004	Pawls Carrier Gear Z13 N4	28	1	S4160400B1	Cover 2 Speed W70
12	2	A72821800	Roller Bearing 14/20/18	29	1	A94136400	Assy Socket W20-80 Socket Handle W20/80 Washer Ø7.7xØ25x5.8 Screw M8x20 UNI 6109
13	1	S416030004	Gear Pin Ø12xØ18x52,5		1	S415130085	
14	1	S414760004	Idler and Pinion Z26/Z13 W70		1	M0614303	
15	2	A74162300	Roll bearing 24x18x18				
16	1	A94146800	Assy Housing Winch 70 Housing W70				
	2	S415580085	Bushing Ø12xØ35x9 Support Bushing W70				
	1	S4130900A7	Bushing Ø22xØ25x8.5				
17	6	M0606303	Screw M8x25 UNI 5931				
18	3	A74147500	Roller Bearing Ø102xØ114x26				

*Available with service kit; see website www.harken.com

**Winch product sticker



Radial Winch 70.2 STC

C=drum in chrome bronze

Pos.	Q.ty	Code	Description	Pos.	Q.ty	Code	Description
1	1	A94146700	Assy Base Winch 70 <i>Base W70</i>	19	1	A94147900	Assy Shaft Winch 70 <i>Central shaft W70 ST</i>
	1	S476030004	<i>Centering bushing Ø12</i>		1	S413880002	<i>Washer Ø17.2xØ32x1.5</i>
	1	S4152300A7	<i>Bushing Ø22xØ25x9.5</i>	20			Winch Serial Number Sticker
	2	S415580085	<i>Bushing Ø12xØ35x9</i> <i>Winch Product Sticker**</i>	21	1	S4144300A0	Stripper Arm support W60/70
2	1	S414770004	Gear Z13 W70	22	1	S281700097	Red line
3	1	S413030004	Pawls Carrier Ø8xN2	23	1	A94147100	Assy Jaws winch 70 <i>Lower Jaw W70</i> <i>Upper Jaw W70</i> <i>Peeler W60 - 70</i> <i>SPRING</i>
4	6	S000080003	Pawl Ø8*		1	S414850080	
5	6	S000380001	Pawl Spring Ø8*		4	S385970001	
6	1	S414390041	Ratchet Gear Z21xN2	24	1	A94148800	Drum spare kit Winch 70
7	1	S413120002	Washer Ø22.5xØ45x1				Drum assembly Winch 70 C
8	1	S278170002	Washer Ø12.5xØ48x1.5		50	M0610280	Ball 5/16"
9	1	S281010004	Pin for gear	25	4	M0601803	Screw UNI EN ISO 1207 - M6x35 - A4
10	1	S414420041	Ratchet Gear Z26xN4	26	1	S414730019	Stripper Arm W70
11	1	S414410004	Pawls Carrier Gear Z13 N4	27	3	M0601903	Screw M6x16 UNI1207
12	2	A72821800	Roller Bearing 14/20/18	28	1	S4160400B1	Cover 2 Speed W70
13	1	S416030004	Gear Pin Ø12xØ18x52.5	29	1	A94136400	Assy Socket W20-80 <i>Socket Handle W20/80</i> <i>Washer Ø7.7xØ25x5.8</i> <i>Screw M8x20 UNI 6109</i>
14	1	S414760004	Idler and Pinion Z26/Z13 W70		1	S415130085	
15	2	A74162300	Roll bearing 24x18x18		1	M0614303	
16	1	A94146800	Assy Housing Winch 70 <i>Housing W70</i>				
	2	S415580085	<i>Bushing Ø12xØ35x9</i>				
			<i>Support Bushing W70</i>				
	1	S4130900A7	<i>Bushing Ø22xØ25x8.5</i>				
17	6	M0606303	Screw M8x25 UNI 5931				
18	3	A74147500	Roller Bearing Ø102xØ114x26				

*Available with service kit; see website www.harken.com

**Winch product sticker



Radial Winch 70.2 STCW

CW = chrome/white

Pos.	Q.ty	Code	Description	Pos.	Q.ty	Code	Description
1	1	A96726200W	Assy Base Winch 70 RAL9003 <i>Base W70</i>	19	1	A94147900	Assy Shaft Winch 70 <i>Central shaft W70 ST</i>
	1	S476030004	<i>Centering bushing Ø12</i>		1	S413880002	<i>Washer Ø17.2xØ32x1.5</i>
	1	S4152300A7	<i>Bushing Ø22xØ25x9.5</i>	20			Winch Serial Number Sticker
	2	S415580085	<i>Bushing Ø12xØ35x9</i>	21	1	S4144300A0	Stripper Arm Housing W60/70
	1	S6620700A5W	<i>Skirt W70 RAL9003</i> <i>Winch Product Sticker**</i>	22	-	-	-
2	1	S414770004	Gear Z13 W70	23	1	A94147100W	Assy Jaws winch 70 RAL9003 <i>Lower Jaw W70 RAL9003</i> <i>Upper Jaw W70 RAL9003</i>
3	1	S413030004	Pawls Carrier Ø8xN2		1	S414850080W	<i>Peeler W60 - 70 RAL9003</i>
4	6	S000080003	Pawl Ø8*	4	S385970001	<i>SPRING</i>	
5	6	S000380001	Pawl Spring Ø8*	24	1	A94148800	Drum spare kit Winch 70
6	1	S414390041	Ratchet Gear Z21xN2				Drum assembly Winch 70 W
7	1	S413120002	Washer Ø22.5xØ45x1		50	M0610280	Ball 5/16"
8	1	S278170002	Washer Ø12.5xØ48x1.5	25	4	M0601803	Screw UNI EN ISO 1207 - M6x35 - A4
9	1	S281010004	Pin for gear	26	1	S414730019	Stripper Arm W70
10	1	S414420041	Ratchet Gear Z26xN4	27	3	M0601903	Screw M6x16 UNI1207
11	1	S414410004	Pawls Carrier Gear Z13 N4	28	1	S4160400B1W	Cover 2 Speed W70 RAL9003
12	2	A72821800	Roller Bearing 14/20/18	29	1	A94136400	Assy Socket W20-80 <i>Socket Handle W20/80</i>
13	1	S416030004	Gear Pin Ø12xØ18x52.5		1	S415130085	<i>Washer Ø7.7xØ25x5.8</i>
14	1	S414760004	Idler and Pinion Z26/Z13 W70		1	M0614303	<i>Screw M8x20 UNI 6109</i>
15	2	A74162300	Roll bearing 24x18x18				
16	1	A94146800	Assy Housing Winch 70 <i>Housing W70</i>				
	2	S415580085	<i>Bushing Ø12xØ35x9</i>				
	1	S4130900A7	<i>Support Bushing W70</i> <i>Bushing Ø22xØ25x8.5</i>				
17	6	M0606303	Screw M8x25 UNI 5931				
18	3	A74147500	Roller Bearing Ø102xØ114x26				

*Available with service kit; see website www.harken.com

**Winch product sticker

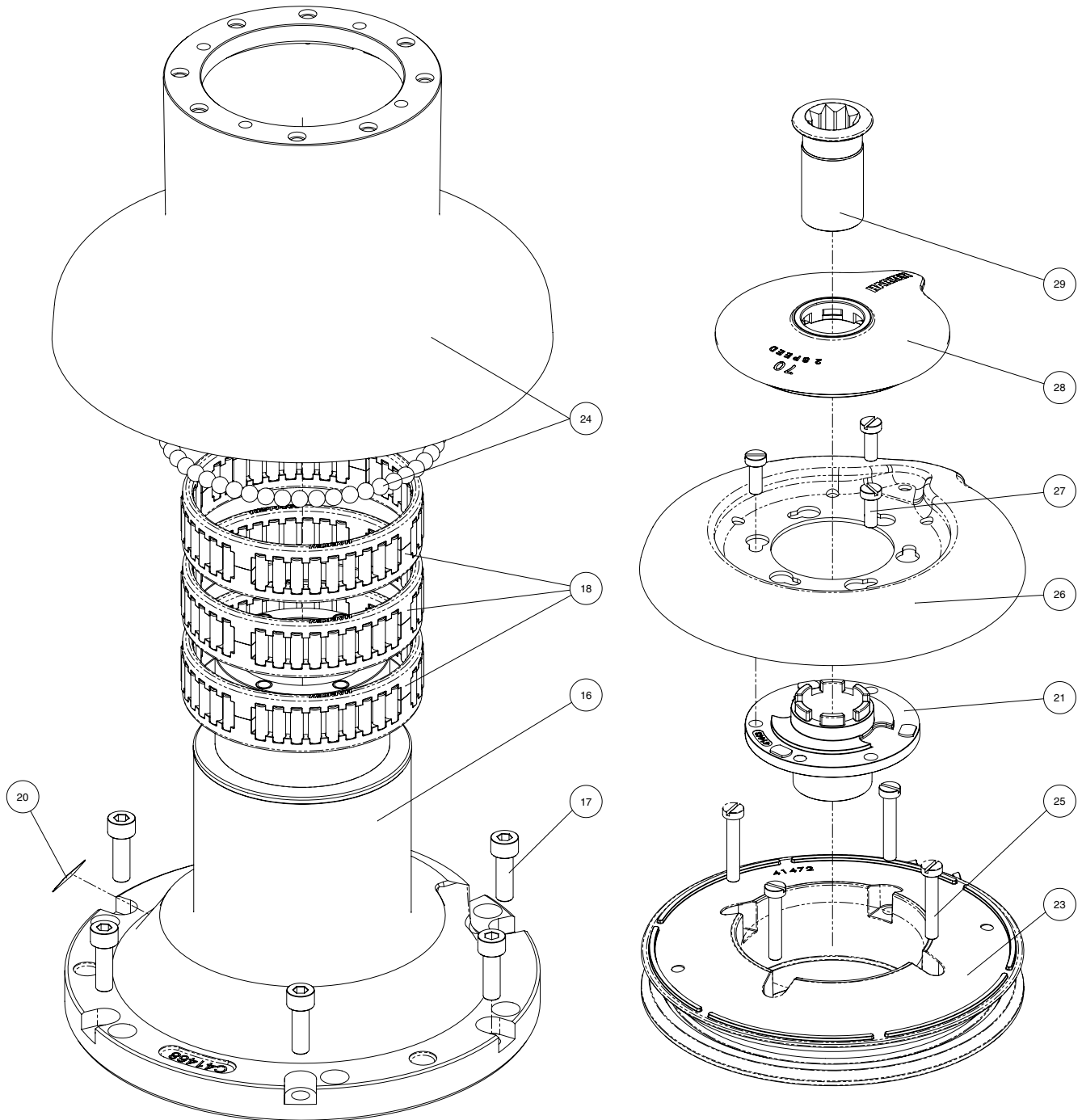

Radial Winch 70.2 STBBB, STCCC

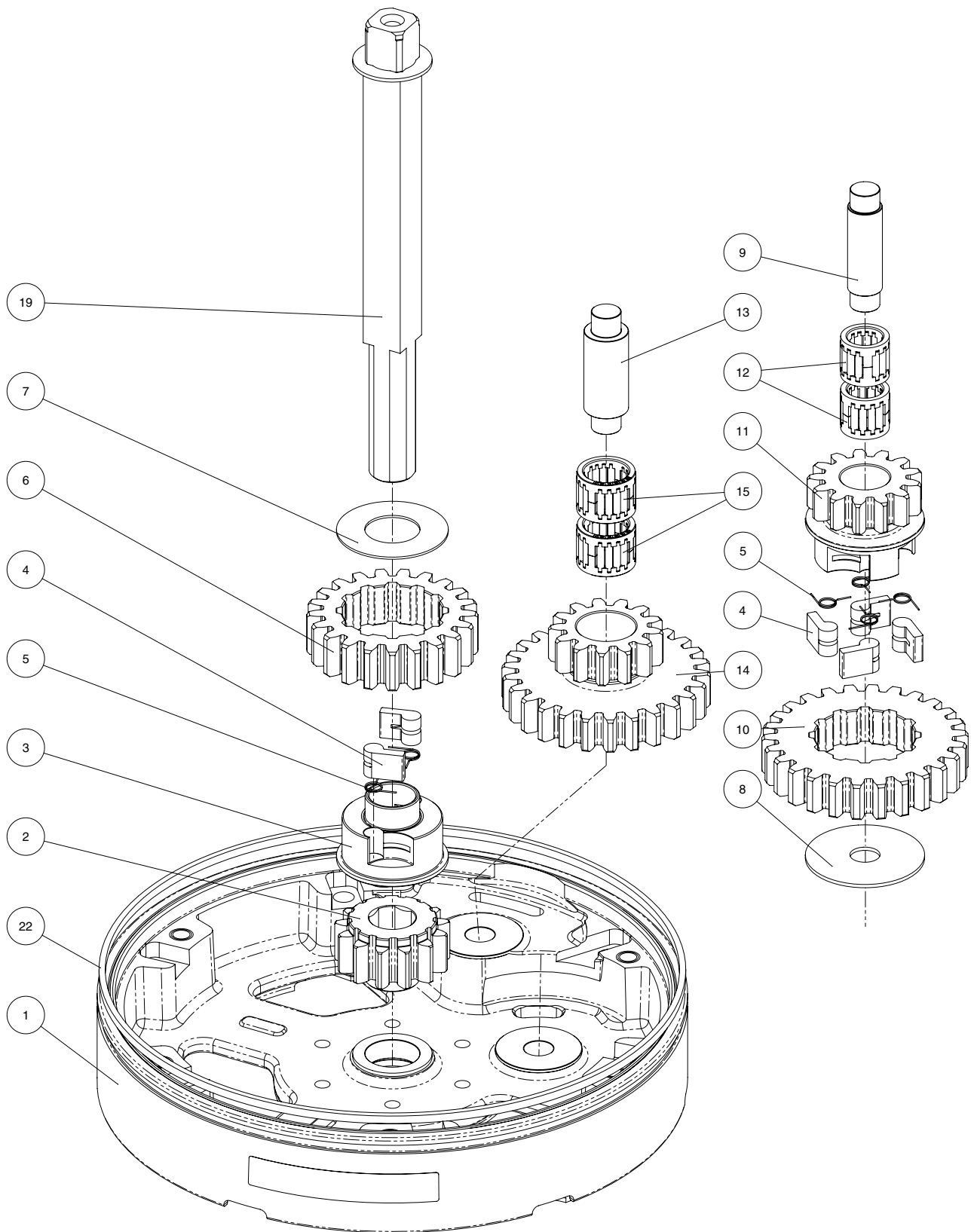
Radial Winch 70.2 STBBB, STCCC

Radial Winch 70.2 STBBB

BBB = all bronze

Pos.	Q.ty	Code	Description	Pos.	Q.ty	Code	Description
1	1	A96980000	Assy Base Winch 70 BBB <i>Base W70</i>	19	1	A94147900	Assy Shaft Winch 70 <i>Central shaft W70 ST</i>
	1	S690880043	<i>Cover for base W70 BBB</i>		1	S413880002	<i>Washer Ø17.2xØ32x1.5</i>
	1	S476030004	<i>Centering bushing Ø12</i>	20			Winch Serial Number Sticker
	1	S4152300A7	<i>Bushing Ø22xØ25x9.5</i>	21	1	S4144300A0	Stripper Arm Housing W60/70
	2	S415580085	<i>Bushing Ø12xØ35x9</i> <i>Winch Product Sticker**</i>	22	1	S281700097	Red line
2	1	S414770004	Gear Z13 W70	23	1	A96924400	Assy Jaws winch 70 ST BBB <i>Lower Jaw W70 BBB</i> <i>Upper Jaw W70</i> <i>Peeler W60 - 70</i> <i>SPRING</i>
3	1	S413030004	Pawls Carrier Ø8xN2		1	S414850080	
4	6	S000080003	Pawl Ø8*		4	S385970001	
5	6	S000380001	Pawl Spring Ø8*	24	1	A96924300	Drum spare kit Winch 70
6	1	S414390041	Ratchet Gear Z21xN2				Drum assembly Winch 70 BBB
7	1	S413120002	Washer Ø22.5xØ45x1		50	M0610280	Ball 5/16"
8	1	S278170002	Washer Ø12.5xØ48x1.5	25	4	M0601803	Screw UNI EN ISO 1207 - M6x35 - A4
9	1	S281010004	Pin for gear	26	1	S7180100F0	Stripper Arm W70 BBB
10	1	S414420041	Ratchet Gear Z26xN4	27	3	M0601903	Screw M6x16 UNI1207
11	1	S414410004	Pawls Carrier Gear Z13 N4	28	1	A76924200	Assy cover W70 BBB
12	2	A72821800	Roller Bearing 14/20/18	29	1	A94136400	Assy Socket W20-80 <i>Socket Handle W20/80</i> <i>Washer Ø7.7xØ25x5.8</i> <i>Screw M8x20 UNI 6109</i>
13	1	S416030004	Gear Pin Ø12xØ18x52.5		1	S415130085	
14	1	S414760004	Idler and Pinion Z26/Z13 W70		1	M0614303	
15	2	A74162300	Roll bearing 24x18x18				
16	1	A94146800	Assy Housing Winch 70 <i>Housing W70</i>				
	2	S415580085	<i>Bushing Ø12xØ35x9</i>				
	1	S4130900A7	<i>Support Bushing W70</i> <i>Bushing Ø22xØ25x8.5</i>				
17	6	M0606303	Screw M8x25 UNI 5931				
18	3	A74147500	Roller Bearing Ø102xØ114x26				

*Available with service kit; see website www.harken.com

**Winch product sticker



Radial Winch 70.2 STCCC

CCC = All-Chrome bronze

Pos.	Q.ty	Code	Description	Pos.	Q.ty	Code	Description
1	1	A96980100	Assy Base Winch 70 CCC <i>Base W70</i>	19	1	A94147900	Assy Shaft Winch 70 <i>Central shaft W70 ST</i>
	1	S690920043	<i>Cover for base W70 CCC</i>		1	S413880002	<i>Washer Ø17.2xØ32x1.5</i>
	1	S476030004	<i>Centering bushing Ø12</i>	20			Winch Serial Number Sticker
	1	S4152300A7	<i>Bushing Ø22xØ25x9.5</i>	21	1	S4144300A0	Stripper Arm Housing W60/70
	2	S415580085	<i>Bushing Ø12xØ35x9</i> <i>Winch Product Sticker**</i>	22	1	S281700097	Red line
2	1	S414770004	Gear Z13 W70	23	1	A96812300	Assy Jaws winch 70 CCC <i>Lower Jaw W70 CCC</i>
3	1	S413030004	Pawls Carrier Ø8xN2		1	S414850080W	<i>Upper Jaw W70 RAL9003</i>
4	6	S000080003	Pawl Ø8*		4	S385970001	<i>Peeler W60 - 70 RAL9003</i> <i>SPRING</i>
5	6	S000380001	Pawl Spring Ø8*	24	1	A94148800	Drum spare kit Winch 70
6	1	S414390041	Ratchet Gear Z21xN2				Drum assembly Winch 70 W
7	1	S413120002	Washer Ø22.5xØ45x1		50	M0610280	Ball 5/16"
8	1	S278170002	Washer Ø12.5xØ48x1.5	25	4	M0601803	Screw UNI EN ISO 1207 - M6x35 - A4
9	1	S281010004	Pin for gear	26	1	S414730019	Stripper Arm W70
10	1	S414420041	Ratchet Gear Z26xN4	27	3	M0601903	Screw M6x16 UNI1207
11	1	S414410004	Pawls Carrier Gear Z13 N4	28	1	A76811600	Assy cover W70 CCC
12	2	A72821800	Roller Bearing 14/20/18	29	1	A94136400	Assy Socket W20-80 <i>Socket Handle W20/80</i>
13	1	S416030004	Gear Pin Ø12xØ18x52.5		1	S415130085	<i>Washer Ø7.7xØ25x5.8</i>
14	1	S414760004	Idler and Pinion Z26/Z13 W70		1	M0614303	<i>Screw M8x20 UNI 6109</i>
15	2	A74162300	Roll bearing 24x18x18				
16	1	A94146800	Assy Housing Winch 70 <i>Housing W70</i>				
	2	S415580085	<i>Bushing Ø12xØ35x9</i>				
	1	S4130900A7	<i>Housing Bushing W70</i> <i>Bushing Ø22xØ25x8.5</i>				
17	6	M0606303	Screw M8x25 UNI 5931				
18	3	A74147500	Roller Bearing Ø102xØ114x26				

*Available with service kit; see website www.harken.com

**Winch product sticker

