

Installation and Maintenance Manual

MRW-I

Powered Radial Winch 70.2 ST EL/HY

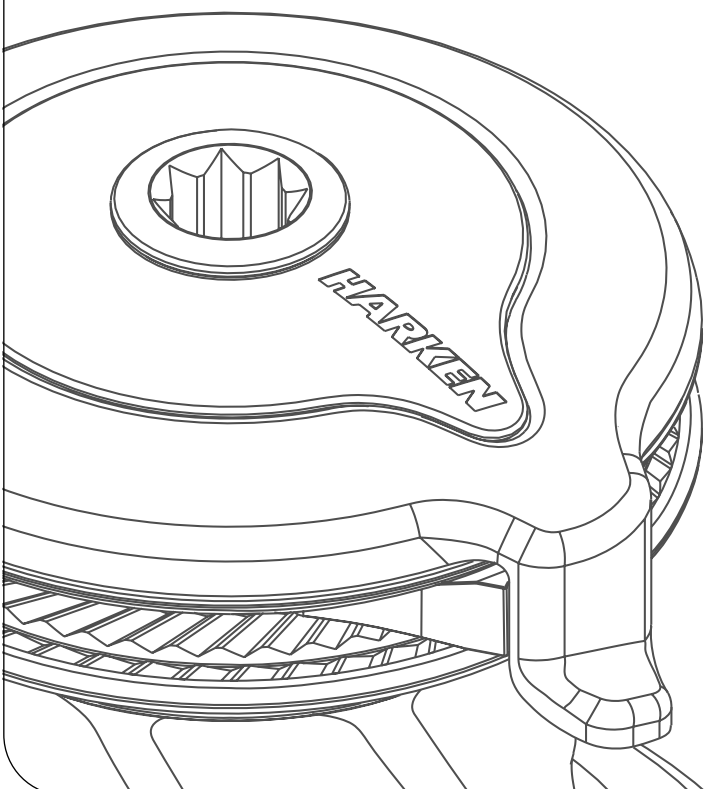

HARKEN[®]

Introduction	3
Technical characteristics	3
<i>Maximum working load</i>	3
<i>Performance data</i>	4
<i>Weight</i>	4
Outline	5
Installation	6
<i>Installation Procedure</i>	7
<i>Winch installation procedure</i>	9
<i>Positioning the self-tailing arm</i>	10
Motor installation procedure	10
<i>Electric wiring diagrams</i>	11
<i>Hydraulic connections diagram</i>	13
<i>Maintenance</i>	14
<i>Washing</i>	14
<i>Maintenance table</i>	14
<i>Disassembly procedure</i>	14
<i>Exploded view with maintenance products</i>	18
<i>Assembly</i>	19
Harken® limited worldwide warranty	20
Ordering spare parts	20
Exploded view	21
<i>Radial Winch 70.2 STA, STC, STCW EL/HY</i>	21
Parts List	23
<i>Radial Winch 70.2 STA EL/HY</i>	23
<i>Radial Winch 70.2 STC EL/HY</i>	24
<i>Radial Winch 70.2 STCW EL/HY</i>	25
Exploded view	26
<i>Radial Winch 70.2 STBBB, STCCC EL/HY</i>	26
Parts List	28
<i>Radial Winch 70.2 STBBB EL/HY</i>	28
<i>Radial Winch 70.2 STCCC EL/HY</i>	29
Exploded view and parts list	30
<i>Horizontal electric motor 12V / 24V / 48V</i>	30
<i>Vertical electric motor 12V / 24V / 48V</i>	31
<i>Hydraulic motor</i>	32

Introduction

This manual gives technical information on winch installation and maintenance, including disassembling and reassembling.

This manual is available only in English. If you do not fully understand the English language, do not carry out the operations described in this manual.

This information is DESTINED EXCLUSIVELY for specialised personnel or expert users.

Installation, disassembling and reassembling of the winch by personnel who are not experts may cause serious damage to users and those in the vicinity of the winch.

Harken accepts no responsibility for defective installation or reassembly of its winches.

Installing third-party electrification kits voids the Harken® Limited Worldwide Warranty.

The installer is responsible for complying with all applicable safety regulations:

- Any residual risks must be analyzed based on the boat on which the system is installed and must be managed exclusively by the installing contractor.
- A safety management system must be implemented on each boat, including one or more emergency buttons.

The user remains responsible for the proper inspection and maintenance of each component of the system installed aboard.

Harken assumes no responsibility for the final design or the consequences of an accident.

In case of doubt the Harken Tech Service is at your disposal at techservice@harken.it

NOTICE

To use and understand this manual, user must refer to other documents, available on web site www.harken.com and listed below:

- The Dual Function Control Box user manual, for the use of the Dual Function Control Box.
- The Dual Function Control Box installation manual, for all details, informations, wiring schemes and warnings about its installation

Technical characteristics

	Power ratio	Gear ratio
1st speed	22,20 : 1	5,70 : 1
2nd speed	72,00 : 1	18,50 : 1

The theoretical power ratio does not take friction into account.

Maximum working load



WARNING!

The maximum working load (MWL) for the 70.2 ST Radial Winch is 2700 Kg (5952 lb). Subjecting the winch to loads above the maximum working load can cause the winch to fail or pull off the deck suddenly and unexpectedly during high loads causing severe injury or death.

Performance data
Winch 70.2 ST EL (electric)

	horizontal motor					
	12V (1500W)		24V (2000W)		48V(2000W)	
	1st speed	2nd speed	1st speed	2nd speed	1st speed	2nd speed
line speed (m/min)*	16,1	5	19,4	6	19	7
max load (Kg)	870	2700	870	2700	870	2700

	vertical motor					
	12V (1500W)		24V (2000W)		48V(2000W)	
	1st speed	2nd speed	1st speed	2nd speed	1st speed	2nd speed
line speed (m/min)*	18,5	5,7	22,2	6,9	18,2	5,6
max load (Kg)	870	2700	870	2700	870	2700

*Line speed is measured with no load

	motor nominal power (W)			current absorption at winch MWL (A)		
	12V	24V	48V	12V	24V	48V
horizontal	1500	2000	2000	280	135	190
vertical	1500	2000	2000	250	125	170

Winch 70.2 ST HY (hydraulic)

	1st speed	2nd speed
line speed (m/min)*	27,6	8,5
max load (Kg)***	870	2700

* at 30 l/min oil flow (5,28 Gall/min); *** at 110 bar at 30 l/min

NOTE

The ratio of the line load - pressure is evaluated at nominal flow rate.

The performance is evaluated measuring the pressure and flow on the motor ports.

The performance data are based on oil with a viscosity of 35mm²/s [165 SUS] and temperature of 50°C [120°F].

Weight

	ST A EH	ST C/CW EH	ST A EV	ST C/CW EV	ST A H	ST C/CW H
weight (Kg)	22,1	25,9	22,8	26,6	18,8	22,6
	ST BBB EH	ST CCC EH	ST BBB EV	ST CCC EV	ST BBB H	ST CCC H
weight (Kg)	27,5	27,5	28,2	28,2	24,2	24,2

Versions:

A = drum in anodised aluminium; C = drum in chrome bronze; CW = chrome/white

BBB = all bronze; CCC = All-Chrome bronze ;

EH = horizontal electric winch; EV = vertical electric winch; H = vertical hydraulic winch

Outline

Winch 70.2 ST E/LHY

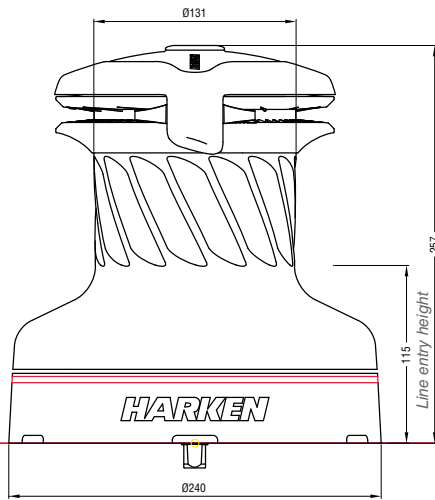

Horizontal electric motor (12V / 24V / 48V)

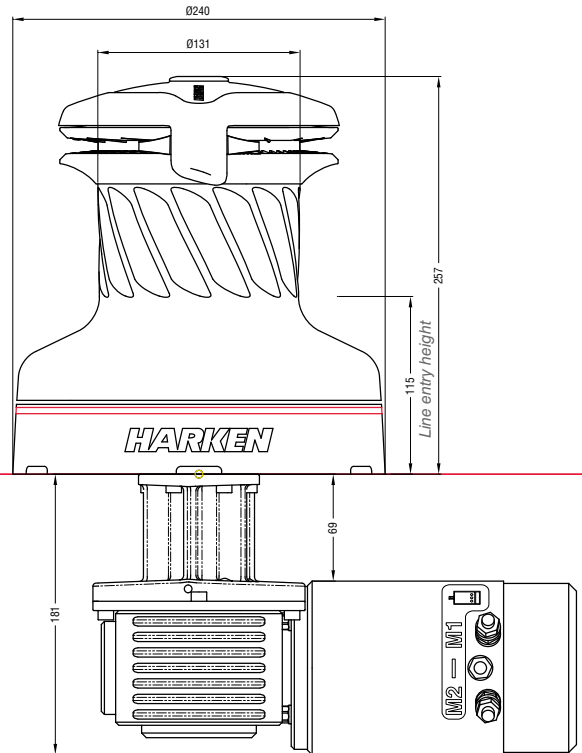

Vertical electric motor (12V / 24V / 48V)

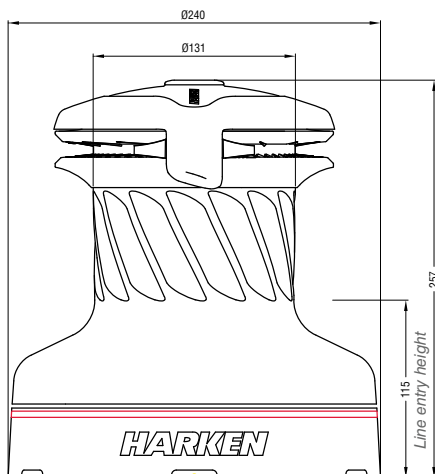

Hydraulic motor

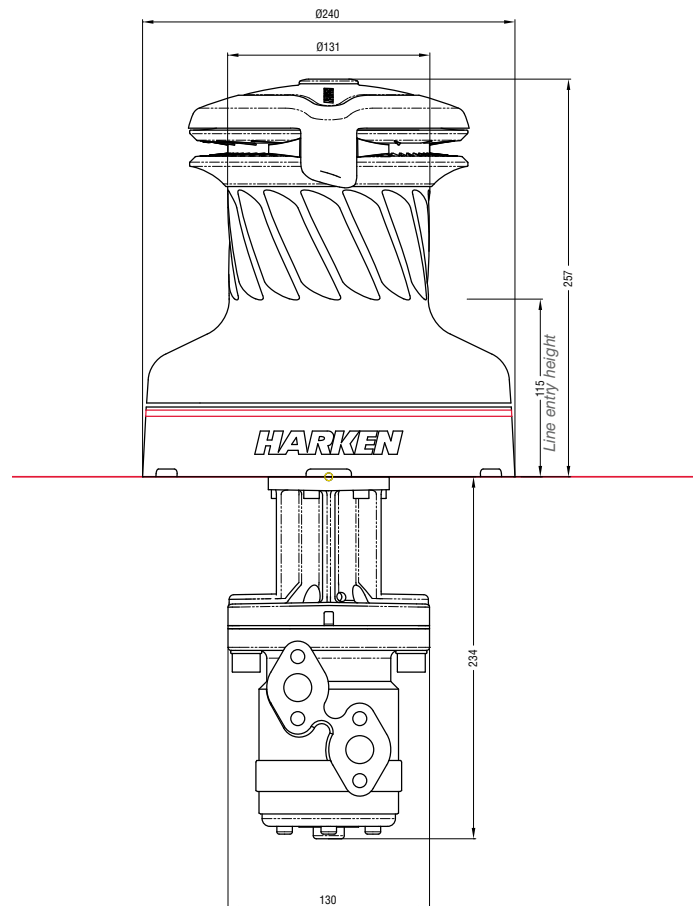

Installation

The winch must be installed on a flat area of the deck, reinforced if necessary to bear a load equal to at least twice the maximum working load of the winch.

It is the installer's responsibility to carry out all structural tests needed to ensure that the deck can bear the load.

Harken does not supply the screws needed to install the winch since these may vary depending on the deck on which it is to be installed.

It is the installer's responsibility to choose the correct screws taking account of the loads they will have to bear.

Harken assumes no responsibility for incorrect installation of its winches or for an incorrect choice of mounting screws.



DANGER!

Incorrect installation of the winch may cause severe injury or death. Consult the yard that built the boat in the case of doubt over the correct positioning of the winch.



WARNING!

Failure to use the correct number and type of mounting fasteners or failure to ensure the correct deck strength can result in the winch pulling off the deck suddenly and unexpectedly during high loads causing severe injury or death.



WARNING!

Verify the entry angle of the sheet. This must be 8° with tolerance of $\pm 2^\circ$, to avoid sheet overrides and damaging the winch or making the winch inoperable leading to loss of control of the boat which can lead to severe injury or death.

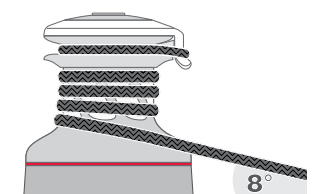

WARNING!

Mount the winch on the deck so that the drive gear is positioned where the sheet enters the winch drum. Incorrect position of drive gear can weaken winch leading to failure which can cause an accident leading to severe injury or death.

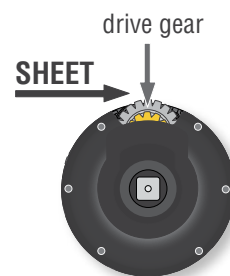

After correctly positioning the final drive gear with respect to the load, check that the motor, gearing, electrical wiring and/or hydraulic pipes can be housed below decks. To help find the optimal compromise, remember that, to make the installation of the motor easier, it can be coupled to the winch in different positions.

Once you have decided the correct mounting position for the winch on the deck and checked the space available below deck, proceed with the installation.

Installation Procedure

To install the winch, remove the drum and use Socket Head (SH) bolts.

Tools needed:  One medium flat-bladed screwdriver

To identify the various parts, refer to the exploded view at the end of this Manual.

 Torque to apply when assembling



1. Pull out the disconnect rod



2. Unscrew the central screw ($\approx 2\text{Nm}/18\text{ in-lb}$)



3. Slide off the assy socket and the cover.
Pay attention to the o-ring in the socket.



4. Unscrew the three screws
($\approx 4\text{Nm}/35\text{ in-lb}$)



5. Remove the self-tailing arm by rotating and lifting it.



6. Lift off the drum

Install the winch on the deck in the position you have chosen, keeping in mind the limits described on page 6 and using socket head (SH) bolts.

Follow steps below only to install the winch using hexagonal headed bolts



7. Completely unscrew the three screws



8. Remove the stripper arm housing



9. Slide out the central shaft



10. Unscrew the 6 hex screws
(20Nm/177 in-lb)



11. Remove the drum support

Important: washer may remain inside the drum support!

Install the winch on the deck in the position you have chosen, keeping in mind the limits described on page 6 and using hexagonal headed (HH) M8 bolts.

Winch installation procedure

Carry out Installation procedure then install the winch on the deck in the chosen position.

NOTICE

Before drilling the deck, check the space available below deck for the flange and the motor

A. Position the base of the winch on the deck and mark the position of the holes or use the drilling cut-out template at the point where you have decided to place the winch.

Below is a reduced scale diagram.

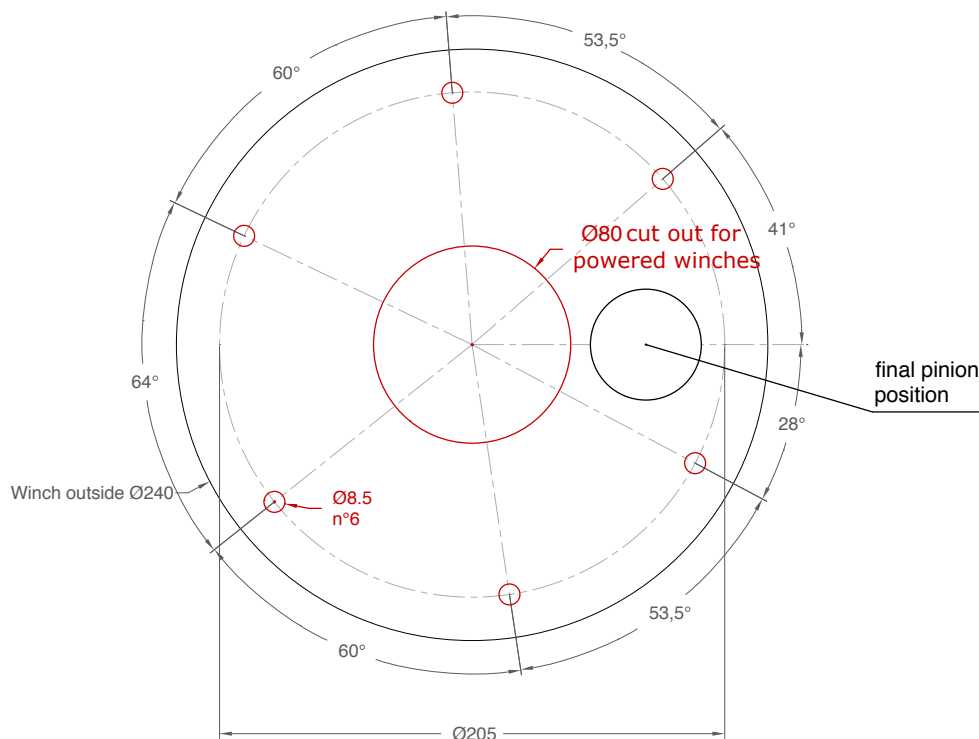

The drilling cut out template is available on the Harken website, www.harken.com

B. Remove the winch and drill the six 8.5 mm and a 80 mm diameter holes.

C. Bolt the base of the winch to the deck using six M8 bolts (not supplied by Harken) correctly chosen for the thickness and type of the boat deck. Consult the yard that built the boat in case of doubt.



WARNING!

To install the winch on the deck, use only bolts in A4 stainless steel (DIN 267 part11).

Bolts made of other materials may not have sufficient strength or may corrode which can result in winch pulling off deck suddenly and unexpectedly during high loads causing severe injury or death.

NOTICE

To mount winches on the deck, do not use countersunk bolts.

D. Fill the mounting holes with a suitable marine sealant.

E. Remove the excess adhesive/sealant from the holes and base drainage channels

F. Reassemble the winch following the steps in **Installation procedure** (page 7) in the reverse order, and apply the products indicated in the section on maintenance.

NOTICE

Before closing the winch, make sure the holes and drainage channels in the base of the winch are not obstructed.

Positioning the self-tailing arm

Position the self-tailing arm so that the line leaving the winch is led into the cockpit.

Motor installation procedure**WARNING!**

Make sure that the power is switched off before installing or carrying out maintenance on the winch.

**WARNING!**

The entire gearmotor assembly is IP54 graded: install the gearmotor under the deck, in a dry place and protected from the external environment, in a position where it is possible to check its status.

Once you have installed the winch on the deck, proceed with motor installation. The motor can be coupled to the winch in different positions. Check the space available below deck and choose the suitable position.

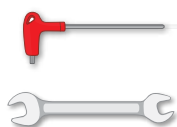
Tools needed

A number five hex key

A number six hex key (only for vertical electric motor)

A number ten hex key (only for hydraulic motor)

Two number thirteen wrenches



1. Position the flange



2. Tighten six M6 precote coated screws
(≈ 8 Nm/ 71 in-lb)



3. Position the reduction gear and motor



4. Tighten the two screws (≈ 8 Nm/ 71in-lb).
Be sure to align the flange.

NOTICE

Before positioning the flange, check to make sure that seals (the first one is above the flange and the second one is under the flange) are seated correctly.



After winch is assembled and before sailing, test the powered winch functioning: insert the lock-in winch handle in the handle socket and check that the disconnect rod must disconnect gearbox.

Electric equipment

To guarantee greater efficiency in terms of safety and long life, for every winch model is mandatory to install the Dual Function Control Box.

To fasten the Dual Function Control Box containing solenoids to bulkhead or wall, for all installation details and for all electric wiring schemes, refer to the Dual Function Control Box manual.



WARNING!

Before installing and using the device, read carefully the Dual Function Control Box manual available on web site www.harken.com

Refer to the following chart for wire size:

Total distance between winch and battery

Winch size	Current voltage	Under 16.4 ft AWG	Under 5 m mm ²	16.4 - 32.8 ft AWG	5 m - 10 m mm ²	32.8 - 49.2 ft AWG	10 m - 15 m mm ²	49.2 - 65.6 ft AGW	15m - 20 m mm ²
70.2	12V	2	32	0	50	00	70	000	95
70.2	24V	5	16	3	25	2	35	0	50
70.2	48V	8	8	6	14	4	18	3	25

Refer to the following chart for HCP model:

Winch size	Current voltage	HCP model	Ampere rating
70.2	12V	HCP1720	135A
70.2	24V	HCP1717	80A
70.2	48V	HCP1717	80A

NOTICE

To connect motor, attach cable terminals to clamps between nut and lock nut. Hold nut in contact with motor using a spanner and tighten other nut with second spanner. Take special care not to turn the central spindles. These instructions apply when assembling and disassembling. We recommend using a torque wrench so as to obtain a torque equal to and no greater than 10 Nm (88 in-lb).



NOTICE

Note that correct electrical contact sequence is:
Nut – Cable Terminal – Self-Locking Washer – Lock Nut



Hydraulic connections diagram

The hydraulic motor must be connected to a hydraulic system using two high-pressure tubes which serve for input or output according to the direction in which the motor will be run. The motor also needs a third connection with a low pressure tube for drainage, so that excess oil can return to the main tank to avoid shortening the life of the motor. This motor uses an open centre valve.

Refer to the following chart for the hydraulic system:

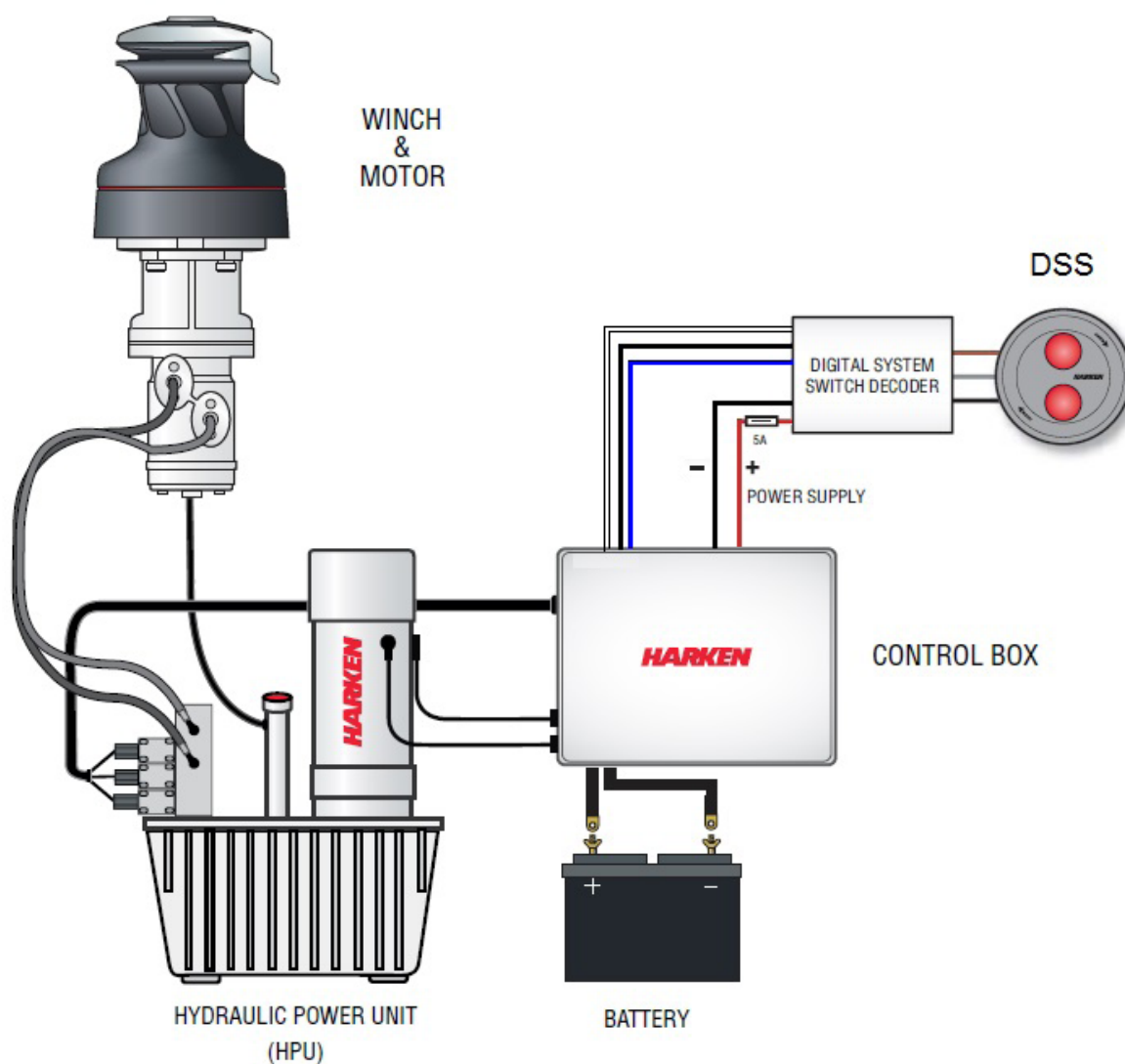

For the hydraulic motor:

Input/output pipe thread: G 1/2 – depth 15 mm

Drainage pipe thread: G 1/4 – depth 12 mm



WARNING!

Refer to the Hydraulic Power Unit and Control Box manual.



WARNING!

Refer to the Digital System Switch manual.

Maintenance

Washing

Winches must be washed frequently with fresh water, and in any case after each use.

Do not allow teak cleaning products or other cleaners containing caustic solutions to come into contact with winches and especially anodised, chrome plated or plastic parts.

Do not use solvents, polishes or abrasive pastes on the logos or stickers on the winches. Do not use polishes or abrasive pastes on anodised, chromed plated or plastics surfaces.

Make sure that the holes and drainage channels in the base of the winch are not obstructed so that water does not collect.

Maintenance table

Winches must be visually inspected at the beginning and end of every season of sailing or racing.

In addition they must be completely overhauled, cleaned and lubricated at least every 12 months.

After an inspection, replace worn or damaged components. Do not replace or modify any part of the winch with a part that is not original.



WARNING!

Periodic maintenance must be carried out regularly. Lack of adequate maintenance shortens the life of the winch, can cause serious injury and also invalidate the winch warranty. Installation and maintenance of winches must be carried out exclusively by specialized personnel.



WARNING!

Make sure that the power is switched off before installing or carrying out maintenance on the winch.

In the case of doubt contact Harken® Tech Service at techservice@harken.it

Disassembly procedure

Tools needed:



One medium flat-bladed screwdriver



A number six hex key



Brush



Rags

To identify the various parts refer to the exploded view at the end of this Manual.

 Torque to be applied in assembly phase

Carry out Installation procedure (page 7) as shown in the paragraph on winch installation and then do the following:



7. Completely unscrew the three screws



8. Remove the stripper arm housing



9. Slide out the central shaft



10. Unscrew the 6 hex screws
(20Nm/177 in-lb)



11. Remove the drum support
Important: washer may remain inside the drum support!



12. Remove the gear, pawls and the washer



13. Remove the gear



14. Remove the idler and pinion



15. Remove roller bearings



16. Remove the pawls



17. Remove the gear



18. Remove roller bearings

If it is necessary to replace any jaws of the winch, proceed as follows:



I. Unscrew the 4 screws
($\approx 4\text{Nm}/35\text{ in-lb}$)



II. Remove the jaws

Inspect balls inside the drum and carefully check the correct position; if it is necessary to put back any balls, push balls in the race (as shown below):



Once the winch is completely disassembled, clean the parts with a degreasing that does not leave residues, proper to clean metal components; rinse plastic parts in fresh water. Once you have done this, dry the parts with cloths that do not leave residue.

Inspect gears, bearings, pins and pawls for any signs of wear or corrosion.

Carefully check the teeth of gears and ring gears to make sure there are no traces of wear.

Check the roller bearings and check there are no breaks in the bearing cages.

Replace worn or damaged components.

Carry out maintenance on components using the products listed below.

For more information on which products to use where, refer to the exploded diagram below.

Use a brush to lightly lubricate all gears, gear pins, teeth and all moving parts with grease.

Lightly lubricate the pawls and springs with oil. Do not use grease on the pawls!

Exploded view with maintenance products

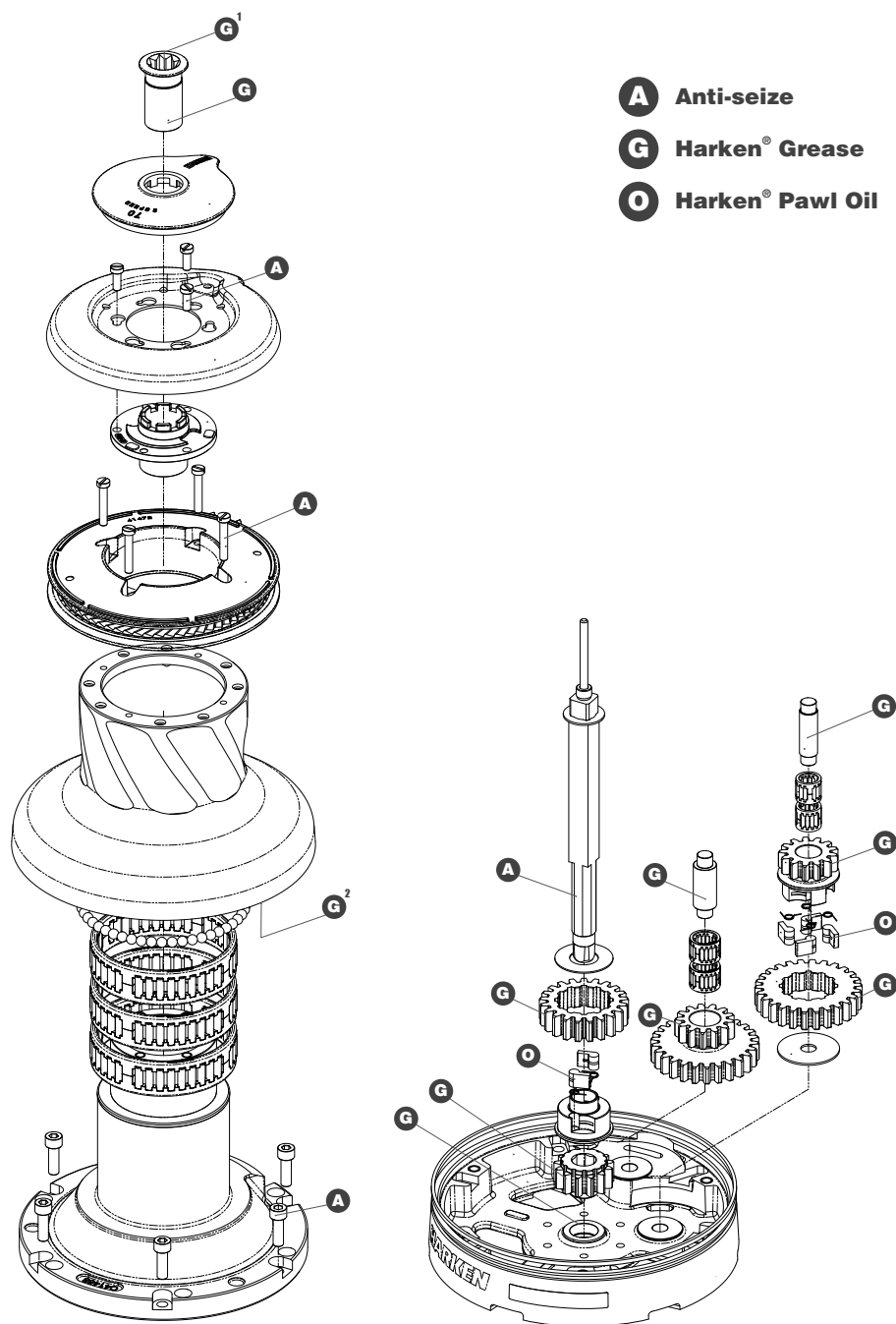

Apply Harken® grease where indicated above
 Apply Harken® grease: 1. on assy socket screw - 2. on drum gear

NOTICE

On every gear and every component that must be greased, apply Harken® grease with a brush in a proper quantity as shown below:



NOTICE

Harken® grease to apply on all teeth: do not use excessive quantity of product to void wastes. If in contact with the pawls, an excess of grease can compromise the safety of the winch.

Assembly

Make sure that the holes and drainage channels in the base of the winch are not obstructed. Assemble the winch in the reverse order of the sequence in the section on disassembly.

To tighten bolts, use the torque indicated in the disassembly procedure.



The icon ▲ on the Stripper Arm Housing indicates the Stripper Arm final position. Change the Stripper Arm Housing angle to modify the Stripper Arm final position.



When positioning the stripper arm, align the peeler with it. If the jaws have been disassembled, insert peeler between the two jaws, taking care that the letters TOP on the peeler are facing upwards.

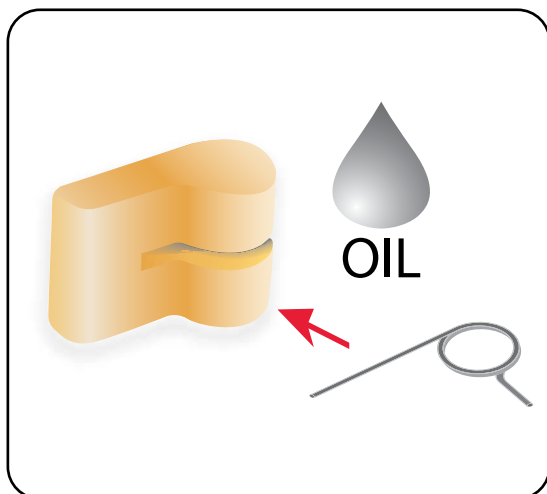

To assemble the pawls
Correctly position the spring in its housing as shown at left. Hold the spring closed and slide the pawl into its housing. Once in position, check that the pawls can be easily opened and closed with a finger.

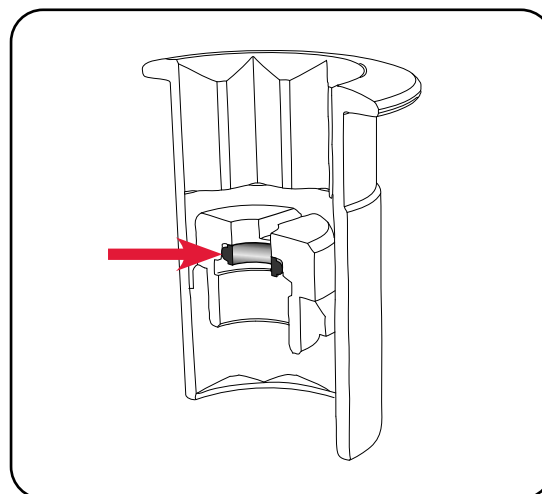

NOTICE
Before screw the central screw, check the correct position of the o-ring in the assy socket and apply Harken® grease.

In case of doubt concerning the assembly procedure contact Harken® Tech Service: techservice@harken.it

Harken® limited worldwide warranty

Refer to the Harken® Limited Worldwide Warranty in the Harken® Catalogue and on the website www.harken.com

Ordering spare parts

Spare parts can be requested from Harken® as described in the Harken® Limited Worldwide Warranty, indicating the part number in the Parts List and including the serial number of the winch for which the parts are required.

The serial number of the winch is printed on a plate on the drum support of the winch.



Manufacturer

Harken® Italy S.p.A.

Via Marco Biagi, 14
22070 Limido Comasco (CO) Italy
Tel: (+39) 031.3523511
Fax: (+39) 031.3520031
Email: info@harken.it
Web: www.harken.com

● **Tech Service**
Email: techservice@harken.it

● **Customer Service**
Tel: (+39) 031.3523511
Email: info@harken.it

Headquarters

Harken®, Inc.

1251 East Wisconsin Avenue
Pewaukee, Wisconsin 53072-3755 USA
Tel: (262) 691.3320
Fax: (262) 691.3008
Email: harken@harken.com
Web: www.harken.com

● **Tech Service**
Email: technicalservice@harken.com

● **Customer Service**
Tel: (262) 691-3320
Email: customerservice@harken.com

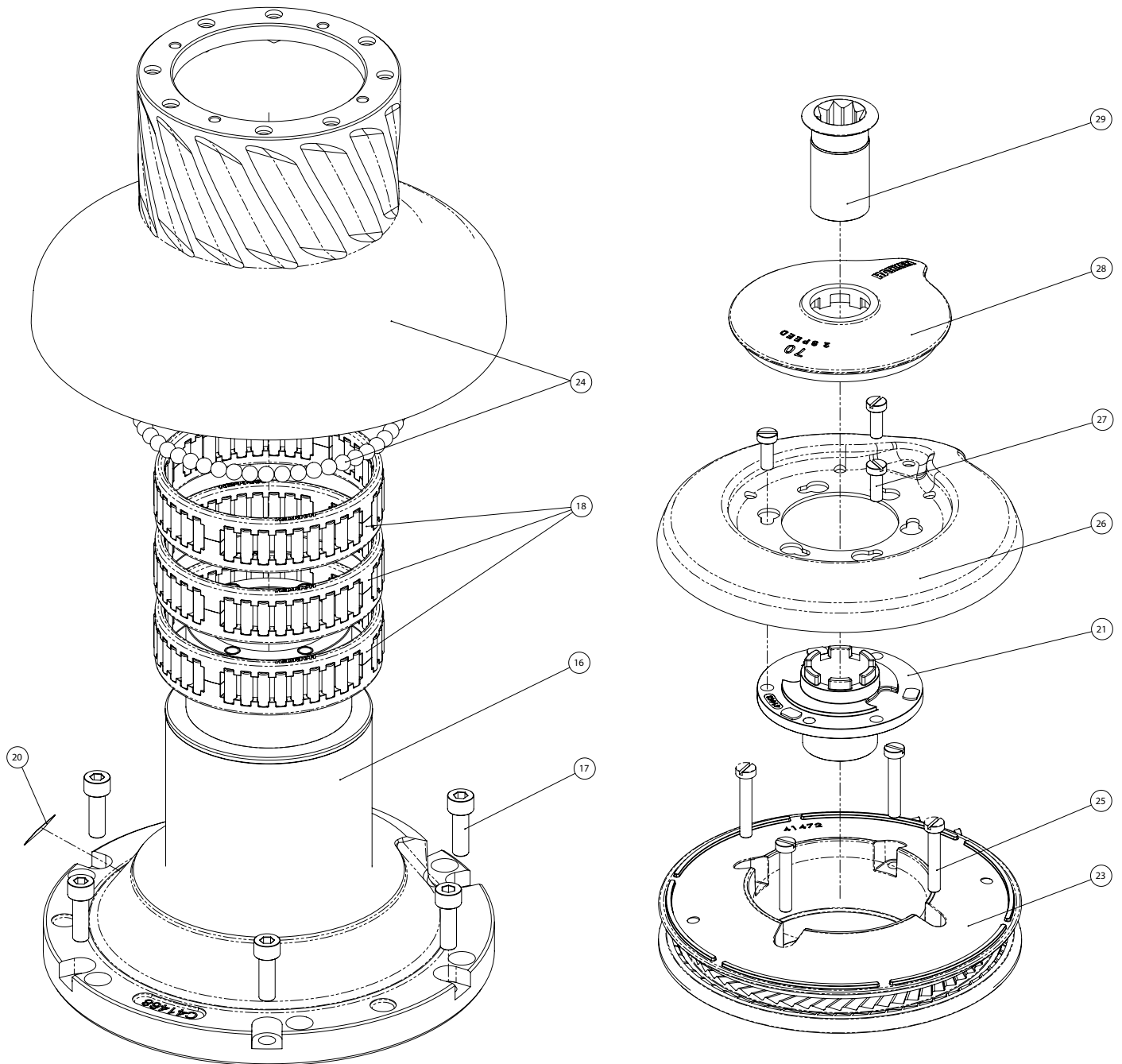
Exploded view*Radial Winch 70.2 STA, STC, STCW EL/HY*

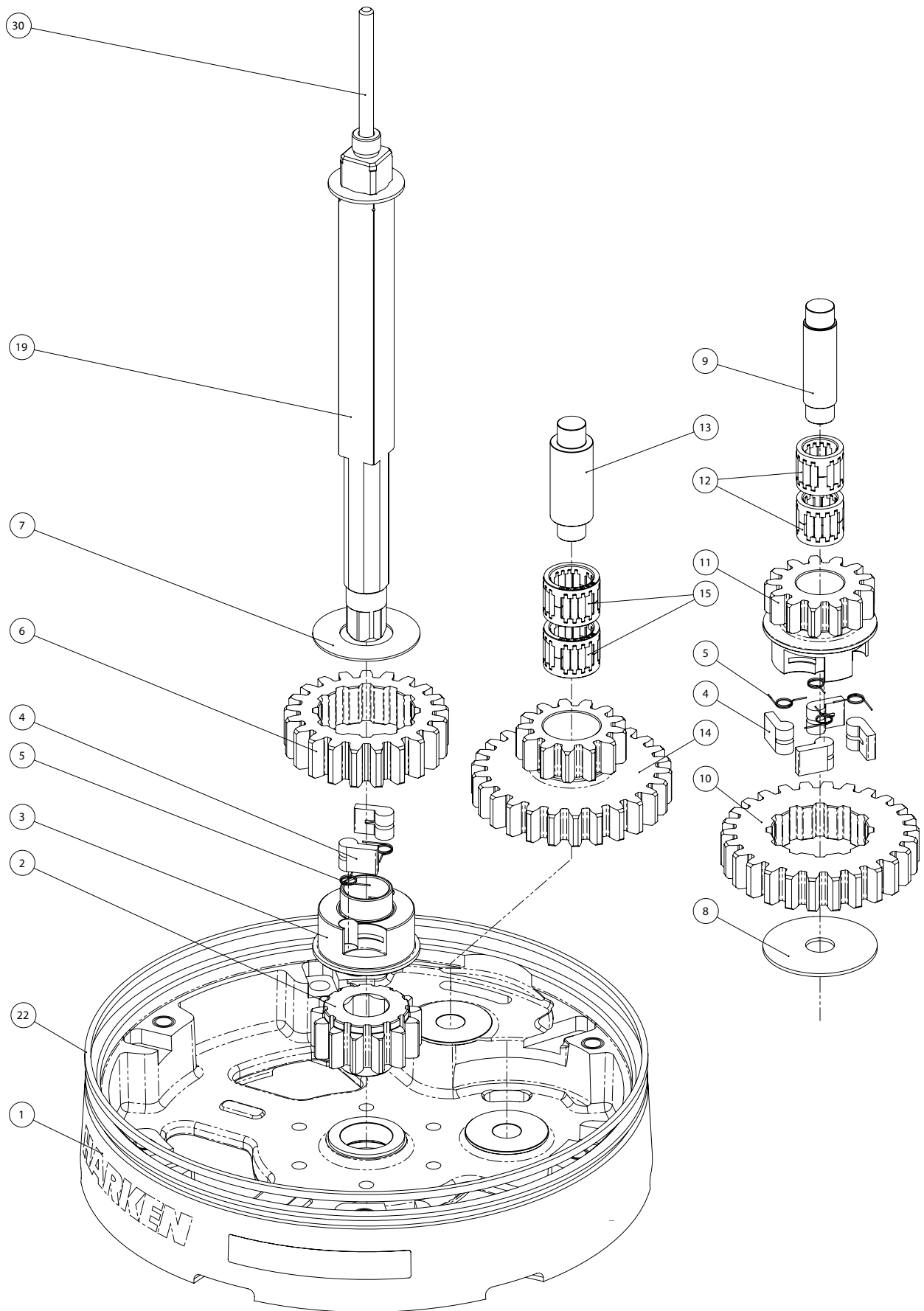
Radial Winch 70.2 STA, STC, STCW EL/HY

Parts List

Radial Winch 70.2 STA EL/HY

A = drum in anodised aluminium

Pos.	Q.ty	Code	Description	Pos.	Q.ty	Code	Description
1	1	A94190000	Assy Base Winch 70 EL/HY <i>Base W70</i>	19	1	A96753500	Assy Shaft Winch 70 EL/HY <i>Central Shaft Pred. W70</i>
	1	S476030004	<i>Centering bushing Ø12</i>		1	S413880002	<i>Washer Ø17.2xØ32x1.5</i>
	1	S4130900A7	<i>Bushing Ø22xØ25x8.5</i>	20			Winch Serial Number Sticker
	2	S415580085	<i>Bushing Ø12xØ35x9</i> <i>Winch Product Sticker**</i>	21	1	S4144300A0	Stripper Arm Housing W60/70
2	1	S414770004	Gear Z13 W70	22	1	S281700097	Red line
3	1	S413030004	Pawls Carrier Ø8xN2	23	1	A94147100	Assy Jaws winch 70 <i>Lower Jaw W70</i> <i>Upper Jaw W70</i> <i>Peeler W60 - 70</i> <i>SPRING</i>
4	6	S000080003	Pawl Ø8*		1	S414850080	
5	6	S000380001	Pawl Spring Ø8*		4	S385970001	
6	1	S414390041	Ratchet Gear Z21xN2	24	1	A96966000	Drum spare kit Winch 70 Drum assembly Winch 70
7	1	S413120002	Washer Ø22.5xØ45x1		50	M0610280	Ball 5/16"
8	1	S278170002	Washer Ø12.5xØ48x1.5	25	4	M0601803	Screw UNI EN ISO 1207- M6x35 - A4
9	1	S281010004	Pin for gear	26	1	S414730019	Stripper Arm W70
10	1	S414420041	Ratchet Gear Z26xN4	27	3	M0601903	Screw M6x16 UNI1207
11	1	S414410004	Pawls Carrier Gear Z13 N4	28	1	S4160400B1	Cover 2 Speed W70
12	2	A72821800	Roller Bearing Ø14xØ20x18	29	1	A94149300	Assy Socket W35-80 EL/HY <i>Socket Handle W20/80</i> <i>Washer Ø25xØ15x4</i> <i>Nut Screw for Disconnect Rod</i> <i>O ring RC 2025 series</i>
13	1	S416030004	Gear Pin Ø12xØ18x52,5		1	S414940085	
14	1	S414760004	Idler and Pinion Z26/Z13 W70		1	S414930003	
15	2	A74162300	Roll bearing Ø24xØ18x18		1	M0679797	
16	1	A94146800	Assy Housing Winch 70 <i>Housing W70</i> <i>Support Bushing W70</i> <i>Bushing Ø12xØ35x9</i> <i>Bushing Ø22xØ25x8.5</i>	30	1	S415090002	Disconnect Rod W70
	2	S415580085					
	1	S4130900A7					
17	6	M0606303	Screw M8x25 UNI 5931				
18	3	A74147500	Roller Bearing Ø102xØ114x26				

*Available with service kit; see website www.harken.com

**Winch product sticker



Radial Winch 70.2 STC EL/HY

C = drum in chrome bronze

Pos.	Q.ty	Code	Description	Pos.	Q.ty	Code	Description
1	1	A94190000	Assy Base Winch 70 EL/HY Base W70	19	1	A96753500	Assy Shaft Winch 70 EL/HY Central Shaft Pred. W70
	1	S476030004	Centering bushing Ø12		1	S413880002	Washer Ø17.2xØ32x1.5
	1	S4130900A7	Bushing Ø22xØ25x8.5	20			Winch Serial Number Sticker
	2	S415580085	Bushing Ø12xØ35x9 Winch Product Sticker**	21	1	S4144300A0	Stripper Arm Housing W60/70
2	1	S414770004	Gear Z13 W70	22	1	S281700097	Red line
3	1	S413030004	Pawls Carrier Ø8xN2	23	1	A94147100	Assy Jaws winch 70 Lower Jaw W70 Upper Jaw W70 Peeler W60 - 70 SPRING
4	6	S000080003	Pawl Ø8*		1	S414850080	
5	6	S000380001	Pawl Spring Ø8*		4	S385970001	
6	1	S414390041	Ratchet Gear Z21xN2	24	1	A94148800	Drum spare kit Winch 70 Drum assembly Winch 70 C
7	1	S413120002	Washer Ø22.5xØ45x1		50	M0610280	Ball 5/16"
8	1	S278170002	Washer Ø12.5xØ48x1.5	25	4	M0601803	Screw UNI EN ISO 1207 - M6x35 - A4
9	1	S281010004	Pin for gear	26	1	S414730019	Stripper Arm W70
10	1	S414420041	Ratchet Gear Z26xN4	27	3	M0601903	Screw M6x16 UNI1207
11	1	S414410004	Pawls Carrier Gear Z13 N4	28	1	S4160400B1	Cover 2 Speed W70
12	2	A72821800	Roller Bearing Ø14xØ20x18	29	1	A94149300	Assy Socket W35-80 EL/HY Socket Handle W20/80 Washer Ø25xØ15x4 Nut Screw for Disconnect Rod O ring RC 2025 series
13	1	S416030004	Gear Pin Ø12xØ18x52,5		1	S414940085	
14	1	S414760004	Idler and Pinion Z26/Z13 W70		1	S414930003	
15	2	A74162300	Roll bearing Ø24xØ18x18		1	M0679797	
16	1	A94146800	Assy Housing Winch 70 Housing W70 Support Bushing W70 Bushing Ø12xØ35x9 Bushing Ø22xØ25x8.5	30	1	S415090002	Disconnect Rod W70
	2	S415580085					
	1	S4130900A7					
17	6	M0606303	Screw M8x25 UNI 5931				
18	3	A74147500	Roller Bearing Ø102xØ114x26				

*Available with service kit; see website www.harken.com

**Winch product sticker



Radial Winch 70.2 STCW EL/HY

CW = chrome/white

Pos.	Q.ty	Code	Description	Pos.	Q.ty	Code	Description
1	1	A96726300W	Assy Base Winch 70 EL/HY RAL9003 <i>Base W70</i>	19	1	A96753500	Assy Shaft Winch 70 EL/HY <i>Central Shaft Pred. W70</i>
	1	S6620700A5W	<i>Skirt W70 RAL9003</i>		1	S413880002	<i>Washer Ø17.2xØ32x1.5</i>
	1	S476030004	<i>Centering bushing Ø12</i>	20			Winch Serial Number Sticker
	1	S4130900A7	<i>Bushing Ø22xØ25x8.5</i>	21	1	S4144300A0	Stripper Arm Housing W60/70
	2	S415580085	<i>Bushing Ø12xØ35x9</i> <i>Winch Product Sticker**</i>	22	-	-	-
2	1	S414770004	Gear Z13 W70	23	1	A94147100W	Assy Jaws winch 70 RAL9003 <i>Lower Jaw W70 RAL9003</i> <i>Upper Jaw W70 RAL9003</i> <i>Peeler W60 - 70 RAL9003</i> <i>SPRING</i>
3	1	S413030004	Pawls Carrier Ø8xN2		1	S414850080W	
4	6	S000080003	Pawl Ø8*		4	S385970001	
5	6	S000380001	Pawl Spring Ø8*	24	1	A94148800	Drum spare kit Winch 70
6	1	S414390041	Ratchet Gear Z21xN2				Drum assembly Winch 70
7	1	S413120002	Washer Ø22.5xØ45x1		50	M0610280	Ball 5/16"
8	1	S278170002	Washer Ø12.5xØ48x1.5	25	4	M0601803	Screw UNI EN ISO 1207- M6x35 - A4
9	1	S281010004	Pin for gear	26	1	S414730019	Stripper Arm W70
10	1	S414420041	Ratchet Gear Z26xN4	27	3	M0601903	Screw M6x16 UNI1207
11	1	S414410004	Pawls Carrier Gear Z13 N4	28	1	S4160400B1W	Cover 2 Speed W70 RAL9003
12	2	A72821800	Roller Bearing Ø14xØ20x18	29	1	A94149300	Assy Socket W35-80 EL/HY <i>Socket Handle W20/80</i> <i>Washer Ø25xØ15x4</i> <i>Nut Screw for Disconnect Rod</i> <i>O ring RC 2025 series</i>
13	1	S416030004	Gear Pin Ø12xØ18x52,5		1	S414940085	
14	1	S414760004	Idler and Pinion Z26/Z13 W70		1	S414930003	
15	2	A74162300	Roll bearing Ø24xØ18x18		1	M0679797	
16	1	A94146800	Assy Housing Winch 70 <i>Housing W70</i> <i>Support Bushing W70</i>	30	1	S415090002	Disconnect Rod W70
	2	S415580085	<i>Bushing Ø12xØ35x9</i>				
	1	S4130900A7	<i>Bushing Ø22xØ25x8.5</i>				
17	6	M0606303	Screw M8x25 UNI 5931				
18	3	A74147500	Roller Bearing Ø102xØ114x26				

*Available with service kit; see website www.harken.com

**Winch product sticker

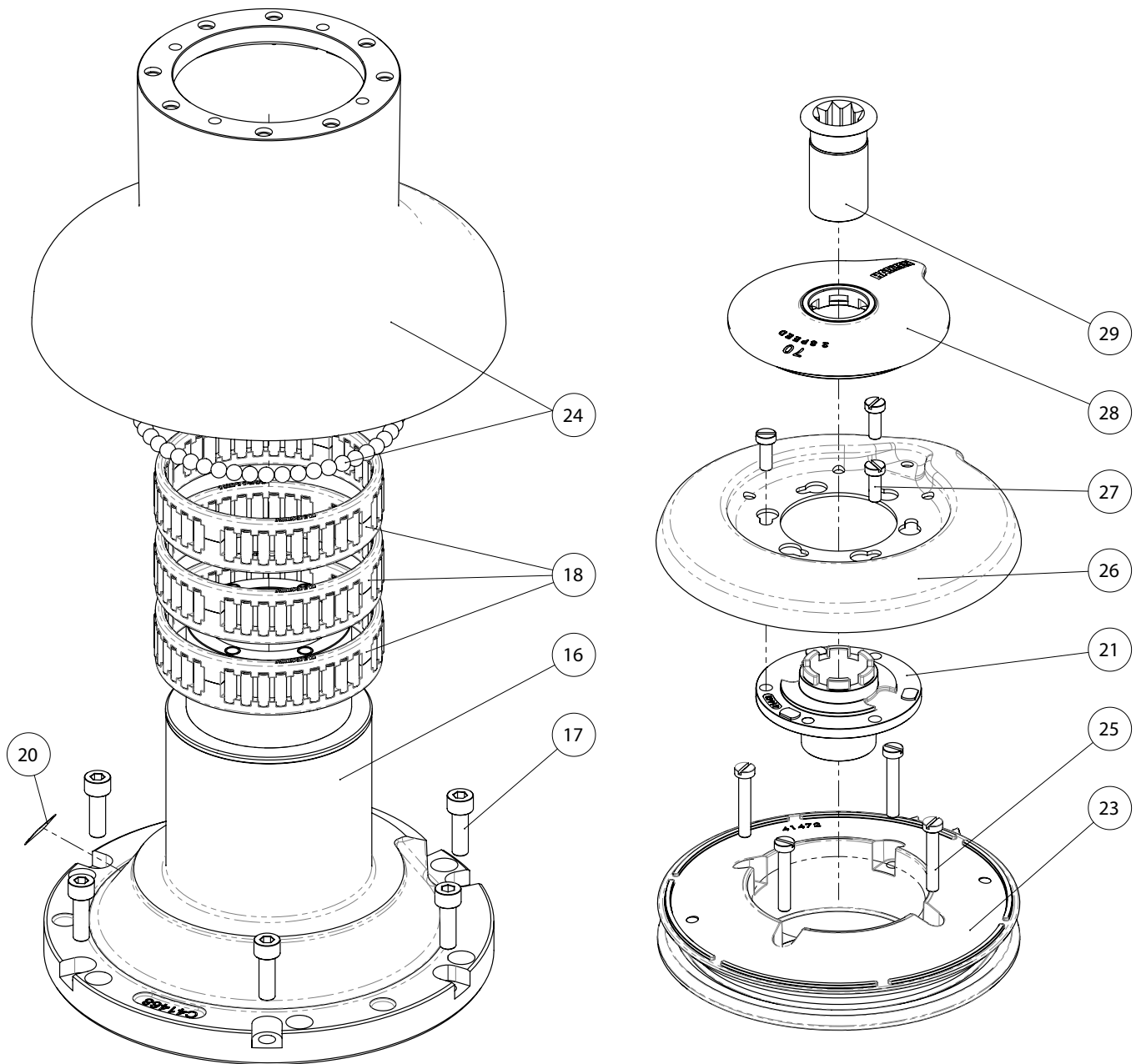

Radial Winch 70.2 STBBB, STCCC EL/HY

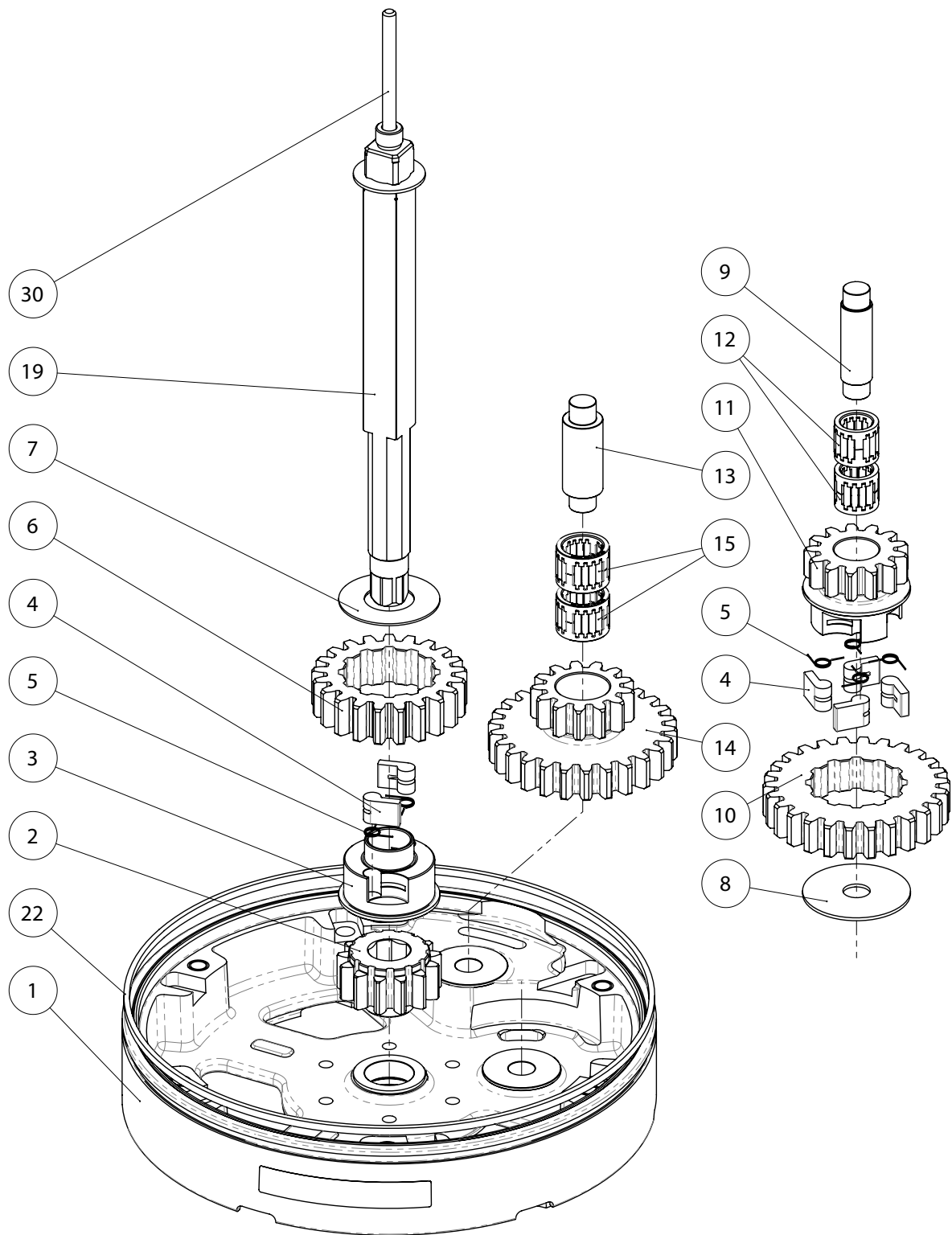
Radial Winch 70.2 STBBB, STCCC EL/HY

Radial Winch 70.2 STBBB EL/HY

BBB = all bronze

Pos.	Q.ty	Code	Description	Pos.	Q.ty	Code	Description
1	1	A96908800	Assy Base Winch 70 B EL/HY <i>Base W70</i>	19	1	A96753500	Assy Shaft Winch 70 EL/HY <i>Central Shaft Pred. W70</i>
	1	S690880043	<i>Cover for base W70 BBB</i>		1	S413880002	<i>Washer Ø17.2xØ32x1.5</i>
	1	S476030004	<i>Centering bushing Ø12</i>	20			Winch Serial Number Sticker
	1	S4130900A7	<i>Bushing Ø22xØ25x8.5</i>	21	1	S4144300A0	Stripper Arm Housing W60/70
	2	S415580085	<i>Bushing Ø12xØ35x9</i> <i>Winch Product Sticker**</i>	22	1	S281700097	Red line
2	1	S414770004	Gear Z13 W70	23	1	A96924400	Assy Jaws winch 70 ST BBB <i>Lower Jaw W70 BBB</i> <i>Upper Jaw W70</i> <i>Peeler W60 - 70</i> <i>SPRING</i>
3	1	S413030004	Pawls Carrier Ø8xN2		1	S414850080	
4	6	S000080003	Pawl Ø8*		4	S385970001	
5	6	S000380001	Pawl Spring Ø8*	24	1	A96924300	Drum spare kit Winch 70
6	1	S414390041	Ratchet Gear Z21xN2				Drum assembly Winch 70 BBB
7	1	S413120002	Washer Ø22.5xØ45x1		50	M0610280	Ball 5/16"
8	1	S278170002	Washer Ø12.5xØ48x1.5	25	4	M0601803	Screw UNI EN ISO 1207- M6x35 - A4
9	1	S281010004	Pin for gear	26	1	S692450047	Stripper Arm W70 BBB
10	1	S414420041	Ratchet Gear Z26xN4	27	3	M0601903	Screw M6x16 UNI1207
11	1	S414410004	Pawls Carrier Gear Z13 N4	28	1	A76924200	Assy cover W70 BBB
12	2	A72821800	Roller Bearing Ø14xØ20x18	29	1	A94149300	Assy Socket W35-80 EL/HY <i>Socket Handle W20/80</i> <i>Washer Ø25xØ15x4</i> <i>Nut Screw for Disconnect Rod</i> <i>O ring RC 2025 series</i>
13	1	S416030004	Gear Pin Ø12xØ18x52,5		1	S414940085	
14	1	S414760004	Idler and Pinion Z26/Z13 W70		1	S414930003	
15	2	A74162300	Roll bearing Ø24xØ18x18		1	M0679797	
16	1	A94146800	Assy Housing Winch 70 <i>Housing W70</i> <i>Support Bushing W70</i>	30	1	S415090002	Disconnect Rod W70
	2	S415580085	<i>Bushing Ø12xØ35x9</i>				
	1	S4130900A7	<i>Bushing Ø22xØ25x8.5</i>				
17	6	M0606303	Screw M8x25 UNI 5931				
18	3	A74147500	Roller Bearing Ø102xØ114x26				

*Available with service kit; see website www.harken.com

**Winch product sticker



Radial Winch 70.2 STCCC EL/HY

CCC = All-Chrome bronze

Pos.	Q.ty	Code	Description	Pos.	Q.ty	Code	Description
1	1	A96909200	Assy Base Winch 70 C EL/HY Base W70	19	1	A96753500	Assy Shaft Winch 70 EL/HY Central Shaft Pred. W70
	1	S690920043	Cover for base W70 CCC		1	S413880002	Washer Ø17.2xØ32x1.5
	1	S476030004	Centering bushing Ø12	20			Winch Serial Number Sticker
	1	S4130900A7	Bushing Ø22xØ25x8.5	21	1	S4144300A0	Stripper Arm Housing W60/70
	2	S415580085	Bushing Ø12xØ35x9 Winch Product Sticker**	22	1	S281700097	Red line
2	1	S414770004	Gear Z13 W70	23	1	A96812300	Assy Jaws winch 70 CCC Lower Jaw W70 CCC Upper Jaw W70 RAL9003 Peeler W60 - 70 RAL9003 SPRING
3	1	S413030004	Pawls Carrier Ø8xN2		1	S414850080W	
4	6	S000080003	Pawl Ø8*		4	S385970001	
5	6	S000380001	Pawl Spring Ø8*	24	1	A94148800	Drum spare kit Winch 70
6	1	S414390041	Ratchet Gear Z21xN2				Drum assembly Winch 70 W
7	1	S413120002	Washer Ø22.5xØ45x1		50	M0610280	Ball 5/16"
8	1	S278170002	Washer Ø12.5xØ48x1.5	25	4	M0601803	Screw UNI EN ISO 1207- M6x35 - A4
9	1	S281010004	Pin for gear	26	1	S414730019	Stripper Arm W70
10	1	S414420041	Ratchet Gear Z26xN4	27	3	M0601903	Screw M6x16 UNI1207
11	1	S414410004	Pawls Carrier Gear Z13 N4	28	1	A76811600	Assy cover W70 CCC
12	2	A72821800	Roller Bearing Ø14xØ20x18	29	1	A94149300	Assy Socket W35-80 EL/HY Socket Handle W20/80 Washer Ø25xØ15x4 Nut Screw for Disconnect Rod O ring RC 2025 series
13	1	S416030004	Gear Pin Ø12xØ18x52,5		1	S414940085	
14	1	S414760004	Idler and Pinion Z26/Z13 W70		1	S414930003	
15	2	A74162300	Roll bearing Ø24xØ18x18		1	M0679797	
16	1	A94146800	Assy Housing Winch 70 Housing W70 Support Bushing W70	30	1	S415090002	Disconnect Rod W70
	2	S415580085	Bushing Ø12xØ35x9				
	1	S4130900A7	Bushing Ø22xØ25x8.5				
17	6	M0606303	Screw M8x25 UNI 5931				
18	3	A74147500	Roller Bearing Ø102xØ114x26				

*Available with service kit; see website www.harken.com

**Winch product sticker



Horizontal electric motor 12V / 24V / 48V

TOP VIEW

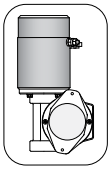

* Motor installed in right-hand configuration.

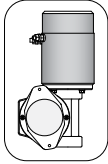

** Motor installed in left-hand configuration.

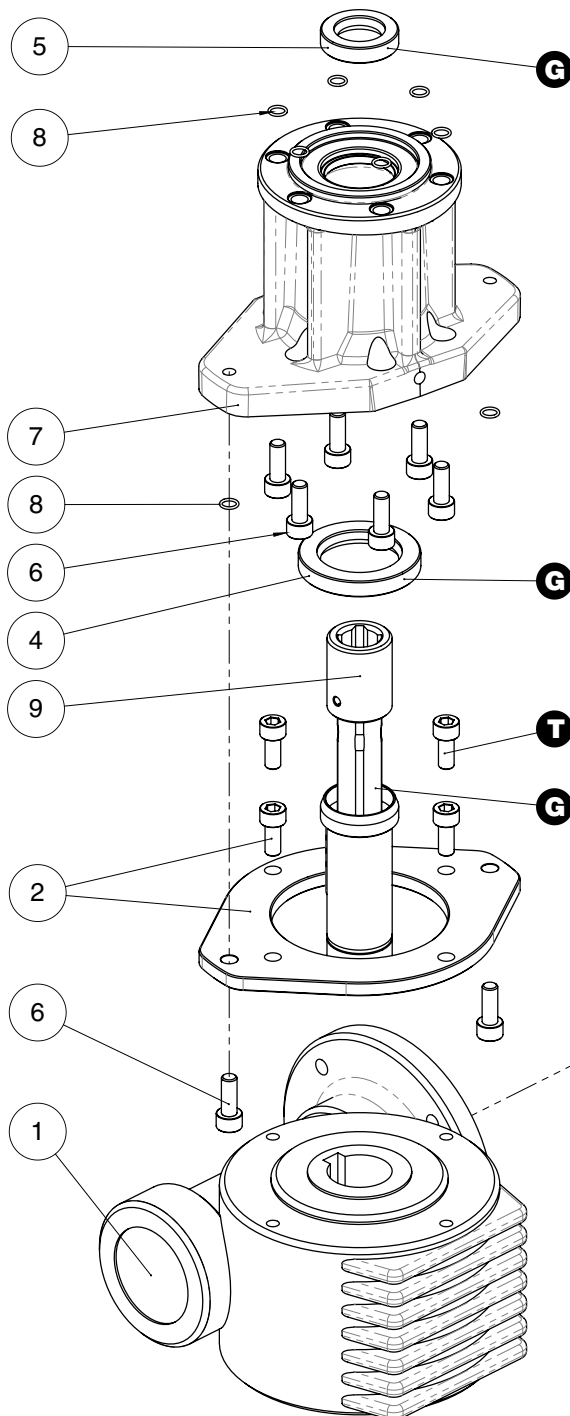

Pos.	Q.ty	Code	Description
1	1	A93127900	KIT Gear Reduction 1/24
	1	A94194900	KIT LM Gear Reduction 1/24
2	1	A94149200	KIT Assy Electric Motor Flange
	1	A94149200L	KIT Assy Electric Motor Flange Left
	4	M0606803	Electric Motor Flange Screw M6x14 UNI 5931
3	1	A96010700	KIT EL Motor 12V 1,5kW
	1	A96010600	KIT EL Motor 24V 2kW
	1	A97707300	KIT EL Motor 48V 2KW
			Electric Motor Polarity motor sticker Screw stud M6x26 Washer Ø6 Nut M6 UNI5588 Key DIN 6885 5x5x15
4	1	M0612097	Sealer Ø30xØ47x7
5	1	M6007297	Lip seal Ø17xØ30x7
6	8	S415360003	Screw M6x16 UNI EN ISO 5931:2003 precote coating
7	1	S496650053	Horizontal Motorgear Flange
8	8	M6015697	O-Ring Seal ORM 0055-10 (Ø5,5 x Ø1)
9	1	A96589000	Performa KIT EL HO Motor Clutch
			Shaft Motorgear HO Performa HO Gear Motor Shaft Hub GearMotor
	1	M0601402	Dowel UNI EN ISO 8752:2000- Ø4x24
	1	M6020097	O-ring 19.1x1.6
	1	S418620001	Disconnect spring
	1	S414050080	Flange GearMotor Shaft HO Key 8x5x40 UNI 7511

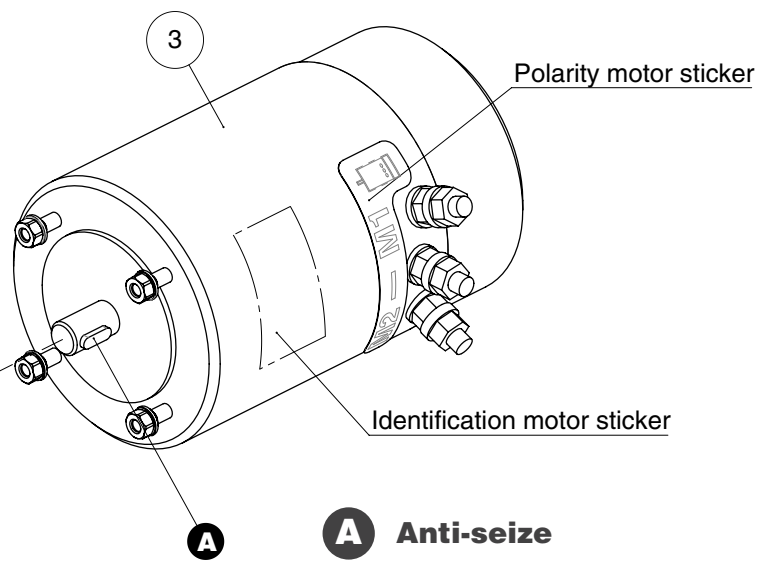

- A** Anti-seize
- G** Harken® Grease
- T** Axial Threadlocker

Vertical electric motor 12V / 24V / 48V

Pos.	Q.ty	Code	Description	Pos.	Q.ty	Code	Description
1	1	A94150500	KIT EL VT Motor Flange		1	S415040080	Bushing
	1		Vertical Motorgear Flange		1	S329360080	Washer
	1		Lip seal 17x30x7		1	M0666603	Screw M6x16 UNI 5933
	6		Seal Ø5,5 x Ø 1	3	1	G601070E	Electric motor 1.5 kW 12V
	6	S415360003	Screw M6x16 UNI EN ISO 5931:2003			G601060E	Electric motor 2kW 24V
	4	M0606303	Screw M8x25 UNI 5931			G603390E	Electric motor 2kW 48V
	4	M0602903	NUT M8 - UNI 5588 - A4	4	1	M6014206	Key DIN 6885 5x5x15
	4	M0603103	WASHER 8.4 U1751 DIN127 A4	5	1	S717830052	Adaptation flange PAM90 B14 PAM71
2	1	A94193700	KIT EL VT Motor Clutch	6	4	M0666603	Screw M6x16 UNI 5933
	1		Connecting Coupling ø31.5	7	4	M7745103	Socket head screw UNI 5931 M8x14 A4
	1		Spring pin 5x40 DIN1481	8	1	S480730063	Sticker ISKRA motor
	1	S326490001	Spring	9	1	A93293700	KIT VT Gearbox (AS16F20.96)
	1	S415030004	Toothed coupling		1		Vertical WormBox 20.96 B5 B5 P71/63
					1		Sticker for gearbox

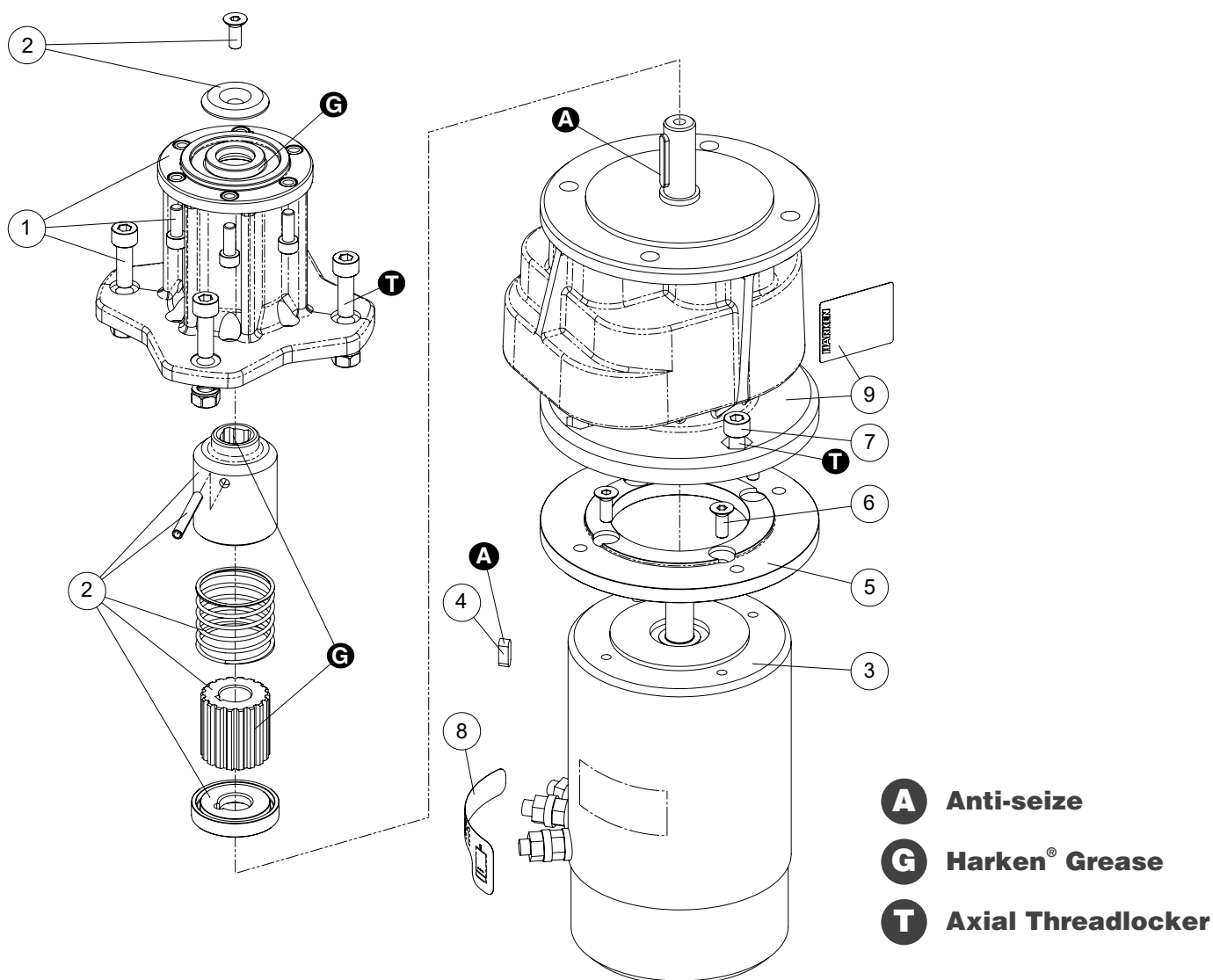

Hydraulic motor

Pos.	Q.ty	Code	Description	Pos.	Q.ty	Code	Description
1	1	G30848000Y	Hydraulic motor W70	4	1	A94149100	KIT HY Motor Flange W46-70
2	1	S415000080	Hydraulic Motor Spacer				<i>Hydraulic Motorgear Flange</i>
3	1	A94193200	KIT Clutch HY Motor W46-70	6	6	S415360003	<i>Screw M6x16 UNI EN ISO 5931:2003 precote coating</i>
			<i>Toothed coupling</i>	6	6	M6015697	<i>O-Ring Seal ORM 0055-10 (Ø5,5 x Ø1)</i>
	1	M0620401	<i>Connecting Coupling Ø31.5</i>	1	1	M6007297	<i>Lip seal Ø17xØ30x7</i>
	1	S415010080	<i>Spring pin 5x40 DIN1481</i>	2	2	M0621503	<i>Washer D.13 U1751 DIN127</i>
	1	S326490001	<i>Bushing</i>	2	2	M0667103	<i>Screw M12x35 UNI5931</i>
	1	S329360082	<i>Spring</i>				
	1	M0635303	<i>Washer</i>				
	1		<i>Screw M8x16 UNI6109</i>				

