

Installation and Maintenance Manual

MRW-F

Radial Winch 70.3 ST

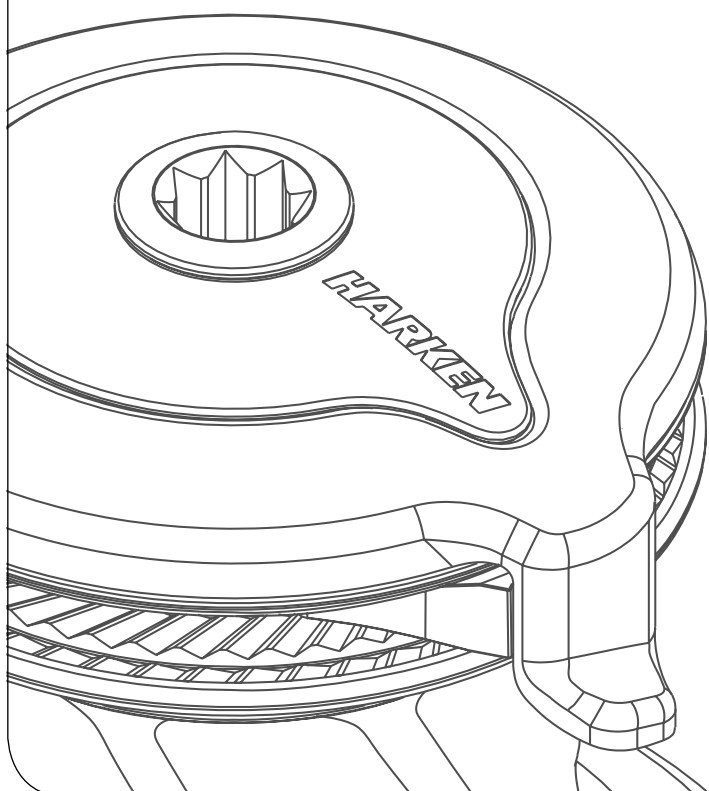

HARKEN[®]

Introduction	3
Technical characteristics	3
<i>Weights</i>	3
<i>Maximum working load</i>	3
Outline	3
Installation	4
<i>Installation procedure</i>	4
<i>Positioning the self-tailing arm</i>	7
Maintenance	8
<i>Washing</i>	8
<i>Maintenance table</i>	8
<i>Disassembly procedure</i>	8
<i>Exploded view with maintenance products</i>	12
<i>Assembly</i>	13
Harken® limited worldwide warranty	14
Ordering spare parts	14
Exploded view	15
<i>Radial Winch 60.3 STA, STC, STCW</i>	15
Parts List	17
<i>Radial Winch 60.3 STA</i>	17
<i>Radial Winch 60.3 STC</i>	18
<i>Radial Winch 60.3 STCW</i>	19
Exploded view	20
<i>Radial Winch 60.3 STBBB, STCCC</i>	20
Parts List	22
<i>Radial Winch 60.3 STBBB</i>	22
<i>Radial Winch 60.3 STCCC</i>	23

Introduction

This manual gives technical information on winch installation and maintenance, including disassembling and reassembling.

This information is DESTINED EXCLUSIVELY for specialised personnel or expert users. Installation, disassembling and reassembling of the winch by personnel who are not experts may cause serious damage to users and those in the vicinity of the winch.

Harken® accepts no responsibility for defective installation or reassembly of its winches.

In case of doubt the Harken® Tech Service is at your disposal at techservice@harken.it

This Manual is available only in English. If you do not fully understand the English language, do not carry out the operations described in this Manual.

Technical characteristics

	Power ratio	Gear ratio
1st speed	9,00 : 1	2,30 : 1
2nd speed	22,20 : 1	5,70 : 1
3rd speed	72,00 : 1	18,50 : 1

The theoretical power ratio does not take friction into account.

Weights

	ST A version	ST C/CW versions	ST BBB/CCC versions
Weight (Kg)	12,8	16,6	18,2

Versions: A = drum in anodised aluminium; C = drum in chrome bronze; CW = chrome/white; BBB = all bronze; CCC = All-Chrome bronze

Maximum working load



WARNING!

The maximum working load (MWL) for the 70.3 ST Radial Winch is 2700 Kg (5952 lb). Subjecting the winch to loads above the maximum working load can cause the winch to fail or pull off the deck suddenly and unexpectedly during high loads causing severe injury or death.

Outline

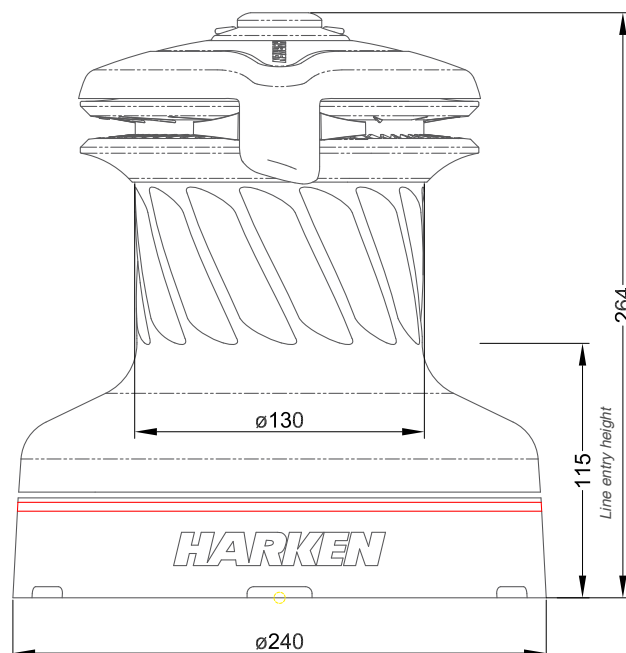

Installation

The winch must be installed on a flat area of the deck, reinforced if necessary to bear a load equal to at least twice the maximum working load of the winch.

It is the installer's responsibility to carry out all structural tests needed to ensure that the deck can bear the load.

Harken® does not supply the screws needed to install the winch since these may vary depending on the deck on which it is to be installed.

It is the installer's responsibility to choose the correct screws taking account of the loads they will have to bear.

Harken® assumes no responsibility for incorrect installation of its winches or for an incorrect choice of mounting screws.



DANGER!

Incorrect installation of the winch may cause severe injury or death. Consult the yard that built the boat in the case of doubt over the correct positioning of the winch.



WARNING!

Failure to use the correct number and type of mounting fasteners or failure to ensure the correct deck strength can result in the winch pulling off the deck suddenly and unexpectedly during high loads causing severe injury or death.



WARNING!

Verify the entry angle of the sheet. This must be 8° with tolerance of $\pm 2^\circ$, to avoid sheet overrides and damaging the winch or making the winch inoperable leading to loss of control of the boat which can lead to severe injury or death.

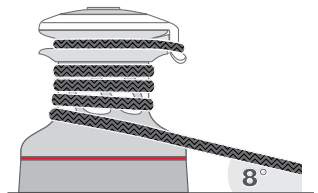

WARNING!

Mount the winch on the deck so that the drive gear is positioned where the sheet enters the winch drum. Incorrect position of drive gear can weaken winch leading to failure which can cause an accident leading to severe injury or death.

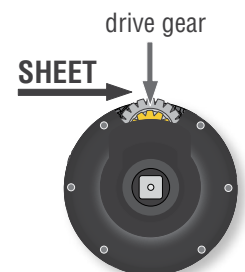

Once you have chosen the correct mounting position for the winch on the deck proceed with installation.

Installation procedure

To install the winch you must remove the drum and use Socket Head (SH) bolts.

Tools needed  One medium flat-bladed screwdriver

To identify the various parts, refer to the exploded view at the end of this Manual.

🔧 Torque to apply when assembling



1. Unscrew the central screw (🔧2Nm/18 in-lb)



2. Slide off the assy socket n°30 and the cover n°29



3. Unscrew the three screws n°28
(🔧4Nm/35 in-lb)



4. Remove the self-tailing arm n°27 by rotating and lifting it.



5. Lift off the drum n°24

Install the winch on the deck in the position you have chosen, keeping in mind the limits described on page 4 and using socket head (SH) bolts.

Follow steps below only to install the winch using hexagonal headed bolts



6. Remove the stripper arm housing n°21



7. Slide out the assy clutch n°38



8. Slide out the central shaft n°19



9. Unscrew the 6 hex screws n°17
($\approx 20\text{Nm}/177\text{ in-lb}$)



10. Remove the drum support n°16

Install the winch on the deck in the position you have chosen, keeping in mind the limits described on page 4 and using hexagonal headed (HH) M8 bolts.

Carry out Installation procedure then install the winch on the deck in the chosen position

A. Position the base of the winch on the deck and mark the position of the holes or use the drilling cut-out template at the point where you have decided to place the winch.

Below is a reduced scale diagram.

The drilling cut out template is available on the Harken® website, www.harken.com

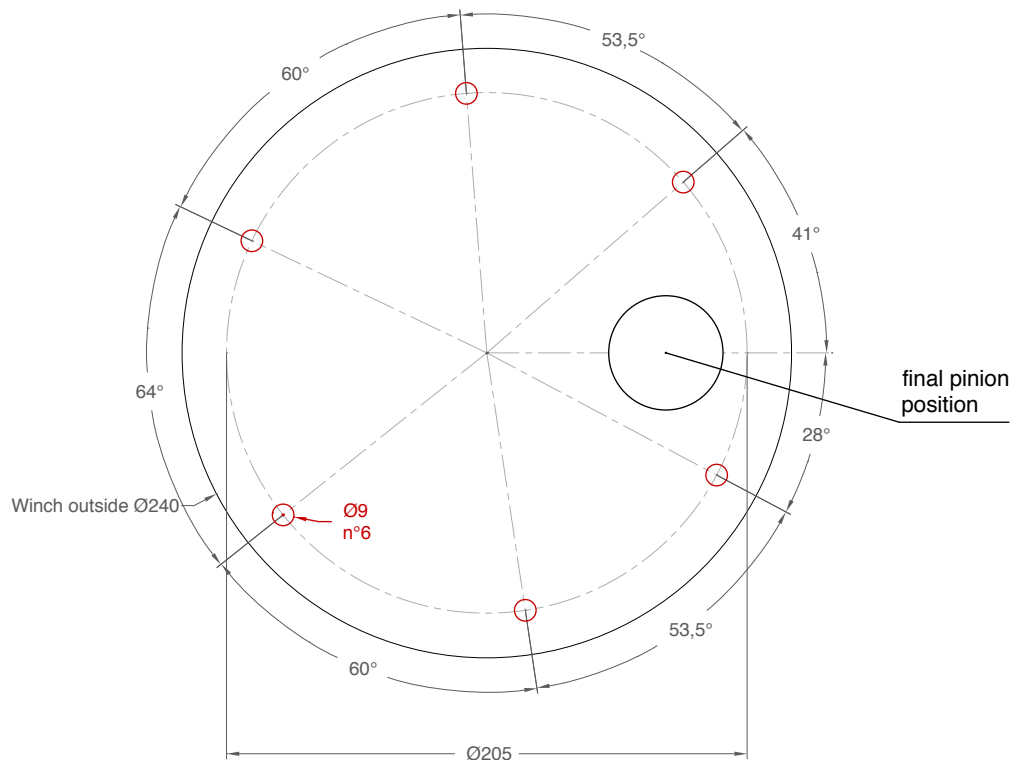

B. Remove the winch and drill the six 9 mm diameter holes.

C. Bolt the base of the winch to the deck using six M8 bolts (not supplied by Harken®), correctly chosen for the thickness and type of the boat deck. Consult the yard that built the boat in case of doubt.



WARNING!

To install the winch on the deck, use only bolts in A4 stainless steel (DIN 267 part11). Bolts made of other materials may not have sufficient strength or may corrode which can result in winch pulling off deck suddenly and unexpectedly during high loads causing severe injury or death.

NOTICE

To mount winches on the deck, do not use countersunk bolts.

D. Fill the mounting holes with a suitable marine sealant.

E. Remove the excess adhesive/sealant from the holes and base drainage channels

F. Reassemble the winch following the steps in Installation procedure (page 4) in the reverse order, and apply the products indicated in the section on maintenance.

NOTICE

Before closing the winch, make sure the holes and drainage channels in the base of the winch are not obstructed.

Positioning the self-tailing arm

Position the self-tailing arm so that the line leaving the winch is led into the cockpit.

Maintenance

Washing

Winches must be washed frequently with fresh water, and in any case after each use.

Do not allow teak cleaning products or other cleaners containing caustic solutions to come into contact with winches and especially anodised, chrome plated or plastic parts.

Do not use solvents, polishes or abrasive pastes on the logos or stickers on the winches. Do not use polishes or abrasive pastes on anodised, chromed plated or plastics surfaces.

Make sure that the holes and drainage channels in the base of the winch are not obstructed so that water does not collect.

Maintenance table

Winches must be visually inspected at the beginning and end of every season of sailing or racing.

In addition they must be completely overhauled, cleaned and lubricated at least every 12 months.

After an inspection, replace worn or damaged components. Do not replace or modify any part of the winch with a part that is not original.



WARNING!

Periodic maintenance must be carried out regularly. Lack of adequate maintenance shortens the life of the winch, can cause serious injury and also invalidate the winch warranty. Installation and maintenance of winches must be carried out exclusively by specialized personnel.

In the case of doubt contact Harken® Tech Service at techservice@harken.it

Disassembly procedure

Tools needed:

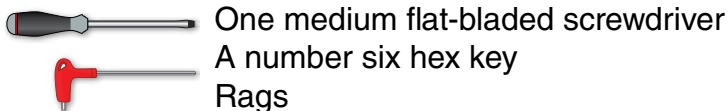

To identify the various parts refer to the exploded view at the end of this Manual.

 Torque to be applied in assembly phase

Carry out **Installation procedure** (page 4) as shown in the paragraph on winch installation and then do the following:



6. Remove the stripper arm housing n°21



7. Slide out the assy clutch n°38



8. Slide out the central shaft n°19



9. Unscrew the 6 hex screws n°17
($\approx 20\text{Nm}/177\text{ in-lb}$)



10. Slide out the drum support n°16



11. Remove the gear n°34, pawls carrier n°33, the bearings n°35 and 37 and the pin n°36
Important: washer n°7 may remain inside the drum support!



12. Remove the gear n°6, pawls carrier n°3 and the washer n°7



13. Remove the idler and pinion n°14



14. Remove the pawl carrier n°11



15. Remove gear n°10



16. Remove the gear n°2



17. Remove the roller bearing n°12



18. Remove roller bearings n°15

If it is necessary to replace any jaws of the winch, proceed as follows:



I. Unscrew the 4 screws n°26
($\approx 4\text{Nm}/35\text{ in-lb}$)



II. Remove the jaws n°23

Inspect balls inside the drum and carefully check the correct position; if it is necessary to put back any balls, push balls in the race (as shown below):



Once the winch is completely disassembled, clean the parts with a degreasing that does not leave residues, proper to clean metal components; rinse plastic parts in fresh water. Once you have done this, dry the parts with cloths that do not leave residue.

Inspect gears, bearings, pins and pawls for any signs of wear or corrosion.

Carefully check the teeth of gears and ring gears to make sure there are no traces of wear.

Check the roller bearings and check there are no breaks in the bearing cages.

Replace worn or damaged components.

Carry out maintenance on components using the products listed below.

For more information on which products to use where, refer to the exploded diagram below.

Use a brush to lightly lubricate all gears, gear pins, teeth and all moving parts with grease.

Lightly lubricate the pawls and springs with oil. Do not use grease on the pawls!

Exploded view with maintenance products

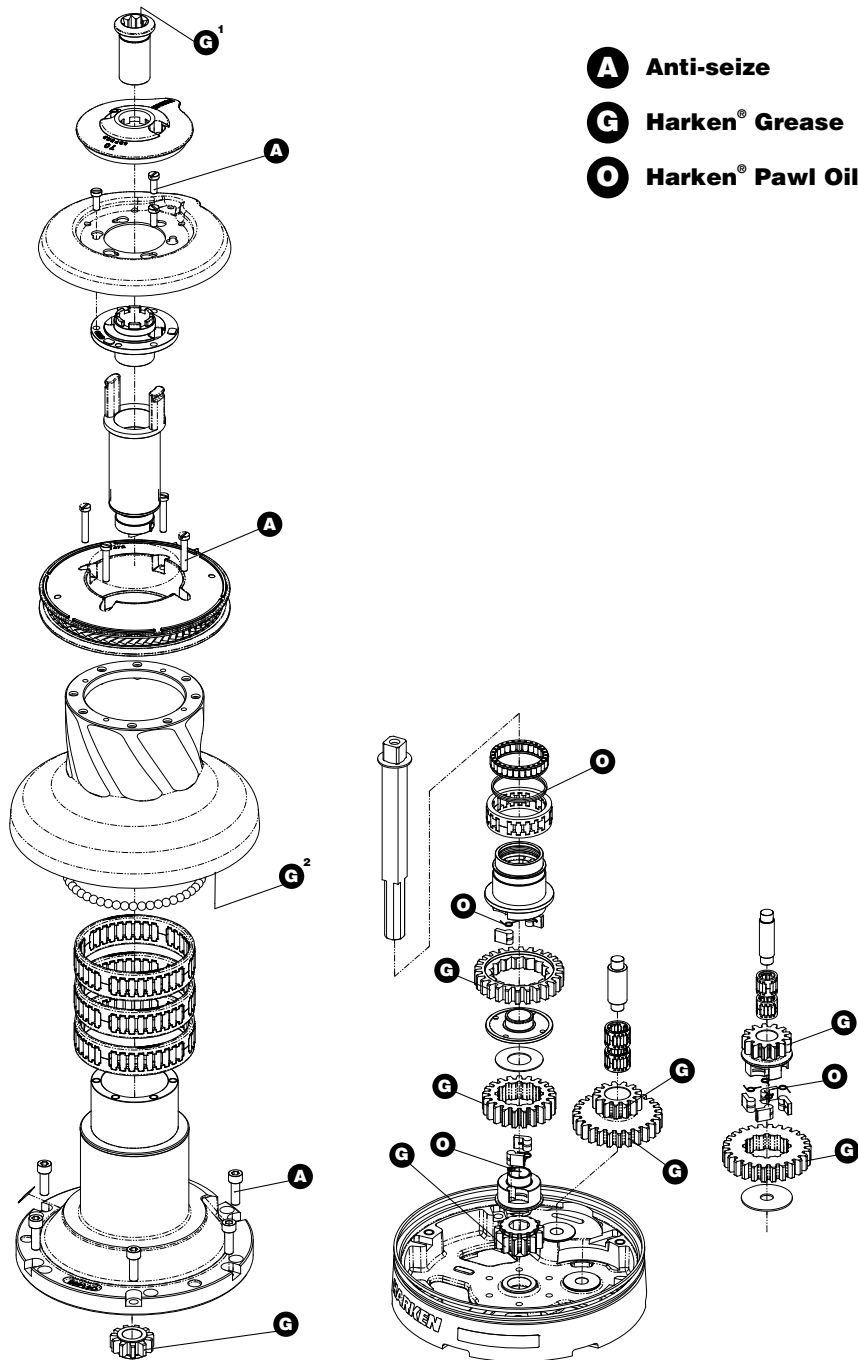

Apply Harken® grease where indicated above
 Apply Harken® grease: 1. on assy socket screw - 2. on drum gear

NOTICE

On every gear and every component that must be greased, apply Harken® grease with a brush in a proper quantity as shown below:



NOTICE

Harken® grease to apply on all teeth: do not use excessive quantity of product to void wastes. If in contact with the pawls, an excess of grease can compromise the safety of the winch.

Assembly

Make sure that the holes and drainage channels in the base of the winch are not obstructed. Assemble the winch in the reverse order of the sequence in the section on disassembly.

To tighten bolts, use the torque indicated in the disassembly procedure.



The icon ▲ on the Stripper Arm Housing indicates the Stripper Arm final position. Change the Stripper Arm Housing angle to modify the Stripper Arm final position.



When positioning the stripper arm, align the peeler with it. If the jaws have been disassembled, insert peeler between the two jaws, taking care that the letters TOP on the peeler are facing upwards.

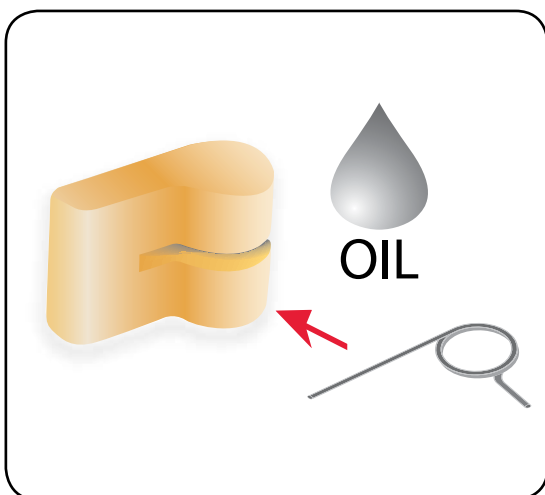

To assemble the pawls
Correctly position the spring in its housing as shown at left. Hold the spring closed and slide the pawl into its housing. Once in position, check that the pawls can be easily opened and closed with a finger.



To assemble the clutch pin
Mount the spring with the pin pointing upwards so that it is wound in an anti-clockwise direction starting from the pin.

In case of doubt concerning the assembly procedure contact Harken® Tech Service: techservice@harken.it

Harken® limited worldwide warranty

Refer to the Harken® Limited Worldwide Warranty in the Harken® Catalogue and on the website www.harken.com

Ordering spare parts

Spare parts can be requested from Harken® as described in the Harken® Limited Worldwide Warranty, indicating the part number in the Parts List and including the serial number of the winch for which the parts are required.

The serial number of the winch is printed on a plate on the drum support of the winch.

**Manufacturer*****Harken® Italy S.p.A.***

Via Marco Biagi, 14
22070 Limido Comasco (CO) Italy
Tel: (+39) 031.3523511
Fax: (+39) 031.3520031
Email: info@harken.it
Web: www.harken.com

- **Tech Service**
Email: techservice@harken.it
- **Customer Service**
Tel: (+39) 031.3523511
Email: info@harken.it

Headquarters***Harken®, Inc.***

1251 East Wisconsin Avenue
Pewaukee, Wisconsin 53072-3755 USA
Tel: (262) 691.3320
Fax: (262) 691.3008
Email: harken@harken.com
Web: www.harken.com

- **Tech Service**
Email: technicalservice@harken.com
- **Customer Service**
Tel: (262) 691-3320
Email: customerservice@harken.com

Exploded view

Radial Winch 70.3 STA, STC, STCW

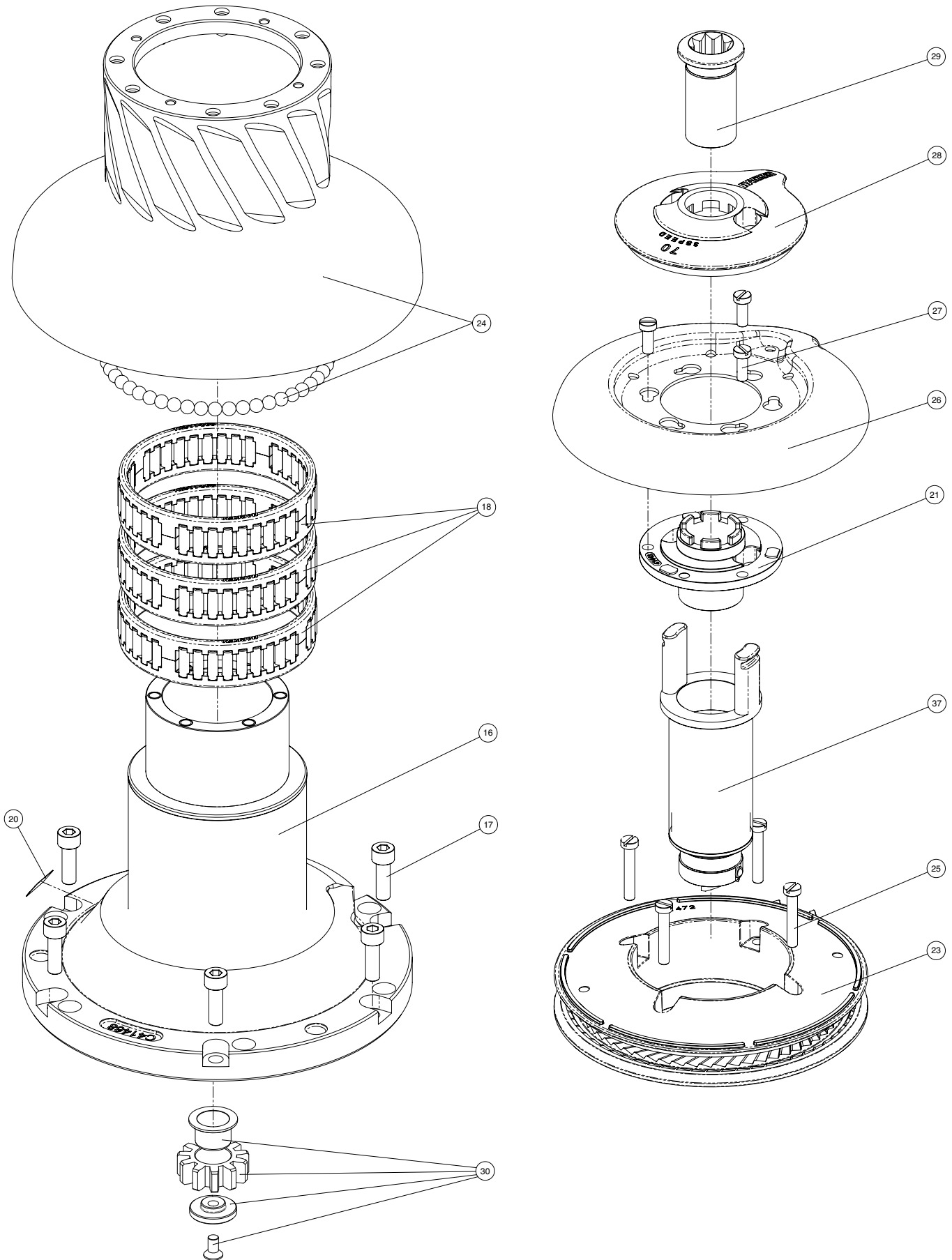

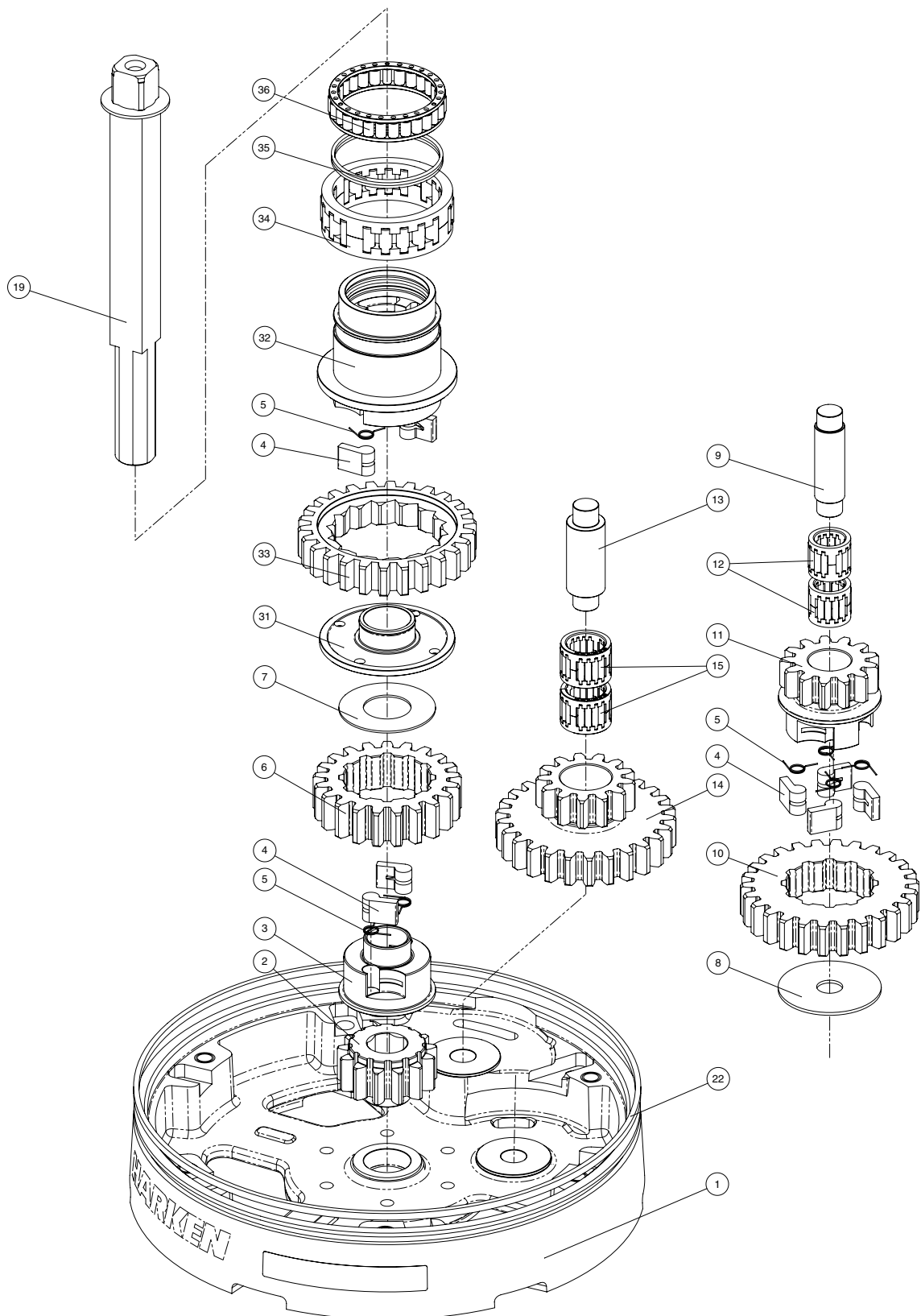
Radial Winch 70.3 STA, STC, STCW

Parts List

Radial Winch 70.3 STA

A= drum in anodised aluminium

Pos.	Q.ty	Code	Description	Pos.	Q.ty	Code	Description
1	1	A94146700	Assy Base Winch 70 Base W70	23	1	A94147100	Assy Jaws winch 70 Lower Jaw W70
	1	S476030004	Centering bushing Ø12				Upper Jaw W70
	1	S4152300A7	Bushing Ø22xØ25x9.5	1	1	S414850080	Peeler W60 - 70
	2	S415580085	Bushing Ø12xØ35x9 Winch Product Sticker**	4	4	S385970001	SPRING
2	1	S414770004	Gear Z13 W70	24	1	A96966000	Drum spare kit Winch 70 Drum assembly Winch 70
3	1	S413030004	Pawls Carrier Ø8xN2		50	M0610280	Ball 5/16"
4	8	S000090004	Pawl Ø8*	25	4	M0601803	Screw UNI EN ISO 1207 - M6x35 - A4
5	8	S000380001	Pawl Spring Ø8*	26	1	S414730019	Stripper Arm W70
6	1	S414390041	Ratchet Gear Z21xN2	27	3	M0601903	Screw M6x16 UNI1207
7	1	S413120002	Washer Ø22.5xØ45x1	28	1	S4155500B1	Cover 3 speed W70
8	1	S278170002	Washer Ø12.5xØ48x1.5	29	1	A94154700	Assy Socket 3speed Socket Handle 3 speed
9	1	S281010004	Pin for gear		1	S415130085	Washer Ø7.7xØ25x5.8
10	1	S414420041	Ratchet Gear Z26xN4		1	M0614303	Screw M8x20 UNI 6109
11	1	S414410004	Pawls Carrier Gear Z13 N4	30	1	A94145300	Assy Gear 3rd speed
12	2	A72821800	Roller Bearing 14/20/18		1	S414530004	Idler Gear 3 speed
13	1	S416030004	Gear Pin Ø12xØ18x52.5		1	S414550081	Bushing Ø22xØ25x15.5
14	1	S414760004	Idler and Pinion Z26/Z13 W70		1	S414540080	Washer 3 speed
15	2	A74162300	Roll bearing 24x18x18		1	M0604003	Screw M6x12 UNI 5933
16	1	A94190900	Assy Housing Winch 70.3 Housing W70	31	1	S414580081	Shim Bushing 3 speed
	2	S415580085	Bushing Ø12xØ35x9	32	1	S415400004	Pawls Carrier 3 speed
	1	S415410081	Bushing 3 speed	33	1	S280870041	Gear 1V
17	6	M0606303	Screw M8x25 UNI 5931	34	1	A73129200	ROLLER BEARING 50-62-20
18	3	A74147500	Roller Bearing Ø102xØ114x26	35	1	S377510001	Clutch Spring
19	1	A94147900	Assy Shaft Winch 70 Central shaft W70 ST	36	1	A73422600	Bearing 45x55x12
	1	S413880002	Washer Ø17.2xØ32x1.5	37	1	A94153700	Assy Clutch 3rd speed W70 Assy Command tube W70
20			Winch Serial Number Sticker		1	S415420004	Dog Clutch 3 speed
21	1	S4155700A0	Stripper arm support		2	M6009463	Spring loaded ball plunger Ø6
22	1	S281700097	Red line				

*Available with service kit; see website www.harken.com

**Winch product sticker



Radial Winch 70.3 STC

C=drum in chrome bronze

Pos.	Q.ty	Code	Description	Pos.	Q.ty	Code	Description
1	1	A94146700	Assy Base Winch 70 Base W70	23	1	A94147100	Assy Jaws winch 70 Lower Jaw W70 Upper Jaw W70
	1	S476030004	Centering bushing Ø12		1	S414850080	Peeler W60 - 70
	1	S4152300A7	Bushing Ø22xØ25x9.5		4	S385970001	SPRING
	2	S415580085	Bushing Ø12xØ35x9 Winch Product Sticker**	24	1	A94148800	Drum spare kit Winch 70
2	1	S414770004	Gear Z13 W70				Drum assembly Winch 70 C
3	1	S413030004	Pawls Carrier Ø8xN2		50	M0610280	Ball 5/16"
4	8	S000090004	Pawl Ø8*	25	4	M0601803	Screw UNI EN ISO 1207 - M6x35 - A4
5	8	S000380001	Pawl Spring Ø8*	26	1	S414730019	Stripper Arm W70
6	1	S414390041	Ratchet Gear Z21xN2	27	3	M0601903	Screw M6x16 UNI1207
7	1	S413120002	Washer Ø22.5xØ45x1	28	1	S4155500B1	Cover 3 speed W70
8	1	S278170002	Washer Ø12.5xØ48x1.5	29	1	A94154700	Assy Socket 3speed Socket Handle 3 speed
9	1	S281010004	Pin for gear		1	S415130085	Washer Ø7.7xØ25x5.8
10	1	S414420041	Ratchet Gear Z26xN4		1	M0614303	Screw M8x20 UNI 6109
11	1	S414410004	Pawls Carrier Gear Z13 N4	30	1	A94145300	Assy Gear 3rd speed
12	2	A72821800	Roller Bearing 14/20/18		1	S414530004	Idler Gear 3 speed
13	1	S416030004	Gear Pin Ø12xØ18x52,5		1	S414550081	Bushing Ø22xØ25x15.5
14	1	S414760004	Idler and Pinion Z26/Z13 W70		1	S414540080	Washer 3 speed
15	2	A74162300	Roll bearing 24x18x18		1	M0604003	Screw M6x12 UNI 5933
16	1	A94190900	Assy Housing Winch 70.3 Housing W70	31	1	S414580081	Shim Bushing 3 speed
	2	S415580085	Bushing Ø12xØ35x9	32	1	S415400004	Pawls Carrier 3 speed
	1	S415410081	Bushing 3 speed	33	1	S280870041	Gear 1V
17	6	M0606303	Screw M8x25 UNI 5931	34	1	A73129200	ROLLER BEARING 50-62-20
18	3	A74147500	Roller Bearing Ø102xØ114x26	35	1	S377510001	Clutch Spring
19	1	A94147900	Assy Shaft Winch 70 Central shaft W70 ST	36	1	A73422600	Bearing 45x55x12
	1	S413880002	Washer Ø17.2xØ32x1.5	37	1	A94153700	Assy Clutch 3rd speed W70 Assy Command tube W70
20			Winch Serial Number Sticker		1	S415420004	Dog Clutch 3 speed
21	1	S4155700A0	Stripper arm support		2	M6009463	Spring loaded ball plunger Ø6
22	1	S281700097	Red line				

*Available with service kit; see website www.harken.com

**Winch product sticker



Radial Winch 70.3 STCW

CW = chrome/white

Pos.	Q.ty	Code	Description	Pos.	Q.ty	Code	Description
1	1	A96726200W	Assy Base Winch 70 RAL9003 <i>Base W70</i>	23	1	A94147100W	Assy Jaws winch 70 <i>Lower Jaw W70 RAL9003</i> <i>Upper Jaw W70 RAL9003</i>
	1	S476030004	<i>Centering bushing Ø12</i>		1	S414850080W	Peeler W60 - 70 RAL9003
	1	S4152300A7	<i>Bushing Ø22xØ25x9.5</i>				
	2	S415580085	<i>Bushing Ø12xØ35x9</i>				
	1	S6620700A5W	<i>Skirt W70 RAL9003</i> <i>Winch Product Sticker**</i>	4	S385970001	SPRING	
2	1	S414770004	Gear Z13 W70	24	1	A94148800	Drum spare kit Winch 70
3	1	S413030004	Pawls Carrier Ø8xN2				Drum assembly Winch 70
4	8	S000090004	Pawl Ø8*		50	M0610280	Ball 5/16"
5	8	S000380001	Pawl Spring Ø8*	25	4	M0601803	Screw UNI EN ISO 1207 - M6x35 - A4
6	1	S414390041	Ratchet Gear Z21xN2	26	1	S414730019	Stripper Arm W70
7	1	S413120002	Washer Ø22.5xØ45x1	27	3	M0601903	Screw M6x16 UNI1207
8	1	S278170002	Washer 12.5x48x1.5	28	1	S4155500B1W	Cover 3 Speed W70 RAL9003
9	1	S281010004	Pin for gear	29	1	A94154700	Assy Socket 3speed <i>Socket Handle 3 speed</i>
10	1	S414420041	Ratchet Gear Z26xN4	1	S415130085	<i>Washer Ø7.7xØ25x5.8</i>	
11	1	S414410004	Pawls Carrier Gear Z13 N4	1	M0614303	<i>Screw M8x20 UNI 6109</i>	
12	2	A72821800	Roller Bearing 14/20/18	30	1	A94145300	Assy Gear 3rd speed
13	1	S416030004	Gear Pin Ø12xØ18x52.5		1	S414530004	<i>Idler Gear 3 speed</i>
14	1	S414760004	Idler and Pinion Z26/Z13 W70		1	S414550081	<i>Bushing Ø22xØ25x15.5</i>
15	2	A74162300	Roll bearing 24x18x18		1	S414540080	<i>Washer 3 speed</i>
16	1	A94190900	Assy Housing Winch 70.3 <i>Housing W70</i>		1	M0604003	<i>Screw M6x12 UNI 5933</i>
	2	S415580085	<i>Bushing Ø12xØ35x9</i>	31	1	S414580081	Shim Bushing 3 speed
	1	S415410081	<i>Bushing 3 speed</i>	32	1	S415400004	Pawls Carrier 3 speed
17	6	M0606303	Screw M8x25 UNI 5931	33	1	S280870041	Gear 1V
18	3	A74147500	Roller Bearing Ø102xØ114x26	34	1	A73129200	ROLLER BEARING 50-62-20
19	1	A94147900	Assy Shaft Winch 70 <i>Central shaft W70 ST</i>	35	1	S377510001	Clutch Spring
	1	S413880002	<i>Washer Ø17.2xØ32x1.5</i>	36	1	A73422600	Bearing 45x55x12
20			Winch Serial Number Sticker	37	1	A94153700	Assy Clutch 3rd speed W70 <i>Assy Command tube W70</i>
21	1	S4155700A0	Stripper arm support	1	S415420004	<i>Dog Clutch 3 speed</i>	
	-	-	-	2	M6009463	<i>Spring loaded ball plunger Ø6</i>	
22	-	-	-				

*Available with service kit; see website www.harken.com

**Winch product sticker



Radial Winch 70.3 STBBB, STCCC

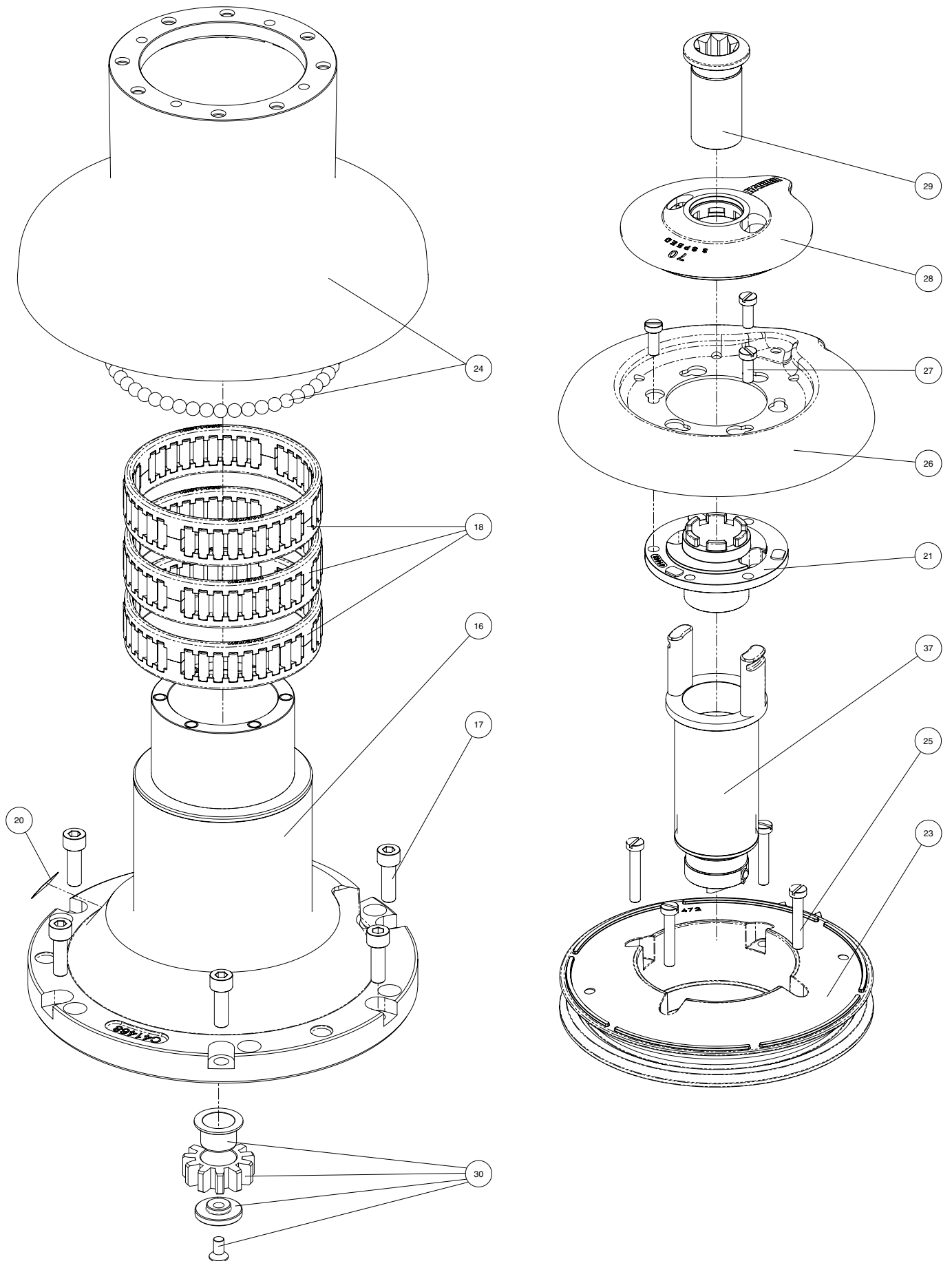

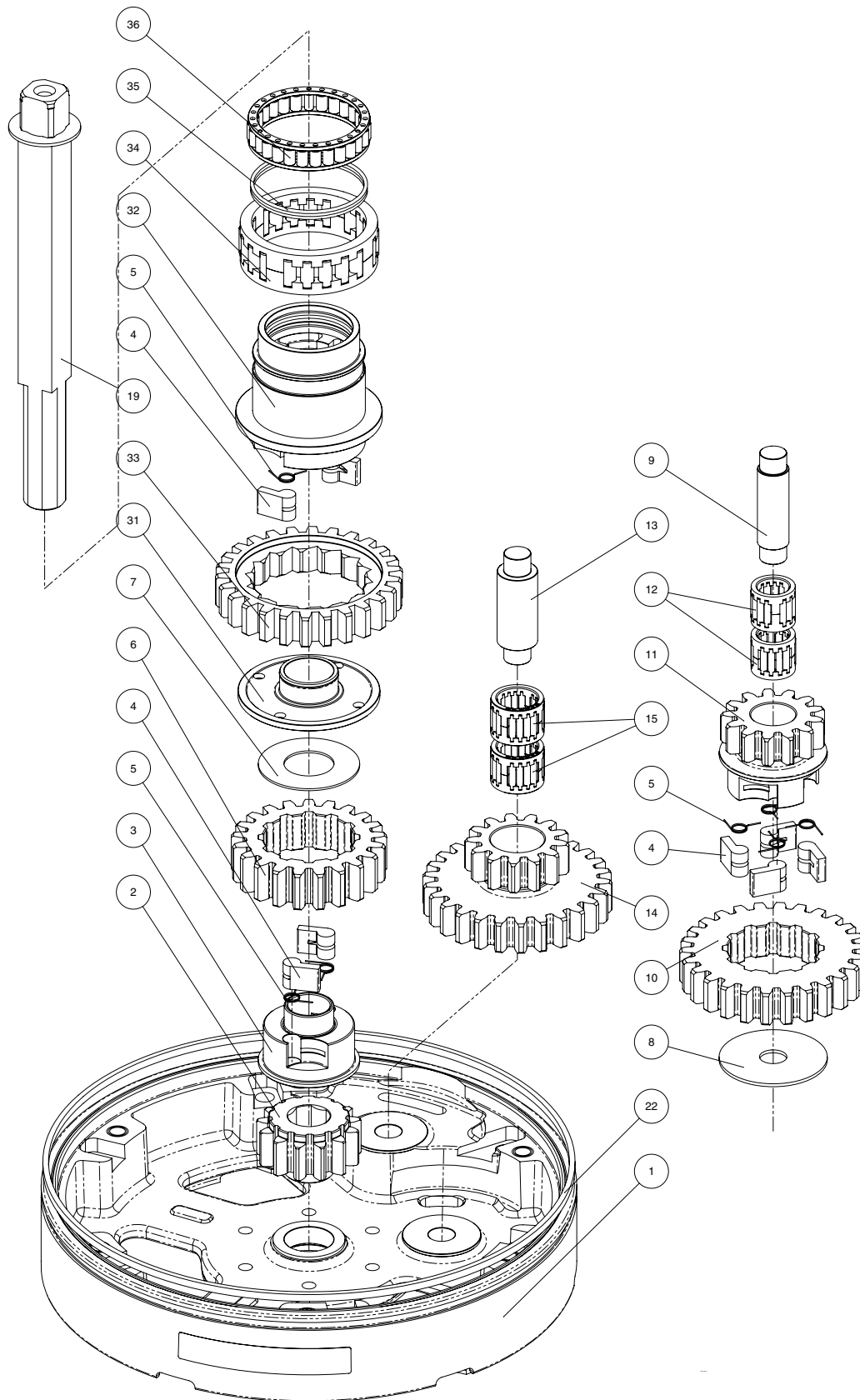
Radial Winch 70.3 STBBB, STCCC

Radial Winch 70.3 STBBB

BBB = all bronze

Pos.	Q.ty	Code	Description	Pos.	Q.ty	Code	Description
1	1	A96980000	Assy Base Winch 70 BBB Base W70	23	1	A96924400	Assy Jaws winch 70 ST BBB Lower Jaw W70 BBB
	1	S690880043	Cover for base W70 BBB				Upper Jaw W70
	1	S476030004	Centering bushing Ø12		1	S414850080	Peeler W60 - 70
	1	S4152300A7	Bushing Ø22xØ25x9.5		4	S385970001	SPRING
	2	S415580085	Bushing Ø12xØ35x9 Winch Product Sticker**	24	1	A96924300	Drum spare kit Winch 70
2	1	S414770004	Gear Z13 W70				Drum assembly Winch 70 BBB
3	1	S413030004	Pawls Carrier Ø8xN2		50	M0610280	Ball 5/16"
4	8	S000090004	Pawl Ø8*	25	4	M0601803	Screw UNI EN ISO 1207 - M6x35 - A4
5	8	S000380001	Pawl Spring Ø8*	26	1	S7180100F0	Stripper Arm W70 BBB
6	1	S414390041	Ratchet Gear Z21xN2	27	3	M0601903	Screw M6x16 UNI1207
7	1	S413120002	Washer Ø22.5xØ45x1	28	1	A76924700	Cover W70.3 Assembly BBB
8	1	S278170002	Washer Ø12.5xØ48x1.5	29	1	A94154700	Assy Socket 3speed Socket Handle 3 speed
9	1	S281010004	Pin for gear		1	S415130085	Washer Ø7.7xØ25x5.8
10	1	S414420041	Ratchet Gear Z26xN4		1	M0614303	Screw M8x20 UNI 6109
11	1	S414410004	Pawls Carrier Gear Z13 N4	30	1	A94145300	Assy Gear 3rd speed
12	2	A72821800	Roller Bearing 14/20/18		1	S414530004	Idler Gear 3 speed
13	1	S416030004	Gear Pin Ø12xØ18x52,5		1	S414550081	Bushing Ø22xØ25x15.5
14	1	S414760004	Idler and Pinion Z26/Z13 W70		1	S414540080	Washer 3 speed
15	2	A74162300	Roll bearing 24x18x18		1	M0604003	Screw M6x12 UNI 5933
16	1	A94190900	Assy Housing Winch 70.3 Housing W70	31	1	S414580081	Shim Bushing 3 speed
	2	S415580085	Bushing Ø12xØ35x9	32	1	S415400004	Pawls Carrier 3 speed
	1	S415410081	Bushing 3 speed	33	1	S280870041	Gear 1V
17	6	M0606303	Screw M8x25 UNI 5931	34	1	A73129200	ROLLER BEARING 50-62-20
18	3	A74147500	Roller Bearing Ø102xØ114x26	35	1	S377510001	Clutch Spring
19	1	A94147900	Assy Shaft Winch 70 Central shaft W70 ST	36	1	A73422600	Bearing 45x55x12
	1	S413880002	Washer Ø17.2xØ32x1.5	37	1	A94153700	Assy Clutch 3rd speed W70 Assy Command tube W70
20			Winch Serial Number Sticker		1	S415420004	Dog Clutch 3 speed
21	1	S4155700A0	Stripper arm support		2	M6009463	Spring loaded ball plunger Ø6
22	1	S281700097	Red line				

*Available with service kit; see website www.harken.com

**Winch product sticker



Radial Winch 70.3 STCCC

CCC = All-Chrome bronze

Pos.	Q.ty	Code	Description	Pos.	Q.ty	Code	Description
1	1	A96980100	Assy Base Winch 70 CCC Base W70	23	1	A96812300	Assy Jaws winch 70 Lower Jaw W70 CCC
	1	S690920043	Cover for base W70 CCC				Upper Jaw W70 RAL9003
	1	S476030004	Centering bushing Ø12	1	4	S414850080W	Peeler W60 - 70 RAL9003
	1	S4152300A7	Bushing Ø22xØ25x9.5	4		S385970001	SPRING
	2	S415580085	Bushing Ø12xØ35x9 Winch Product Sticker**	24	1	A94148800	Drum spare kit Winch 70
2	1	S414770004	Gear Z13 W70				Drum assembly Winch 70
3	1	S413030004	Pawls Carrier Ø8xN2	50		M0610280	Ball 5/16"
4	8	S000090004	Pawl Ø8*	25	4	M0601803	Screw UNI EN ISO 1207 - M6x35 - A4
5	8	S000380001	Pawl Spring Ø8*	26	1	S414730019	Stripper Arm W70
6	1	S414390041	Ratchet Gear Z21xN2	27	3	M0601903	Screw M6x16 UNI1207
7	1	S413120002	Washer Ø22.5xØ45x1	28	1	A76924600	Assy cover W70.3CCC
8	1	S278170002	Washer Ø12.5xØ48x1.5	29	1	A94154700	Assy Socket 3speed Socket Handle 3 speed
9	1	S281010004	Pin for gear				Washer Ø7.7xØ25x5.8
10	1	S414420041	Ratchet Gear Z26xN4	1	1	S415130085	Screw M8x20 UNI 6109
11	1	S414410004	Pawls Carrier Gear Z13 N4	1	1	M0614303	
12	2	A72821800	Roller Bearing 14/20/18	30	1	A94145300	Assy Gear 3rd speed
13	1	S416030004	Gear Pin Ø12xØ18x52,5	1	1	S414530004	Idler Gear 3 speed
14	1	S414760004	Idler and Pinion Z26/Z13 W70	1	1	S414550081	Bushing Ø22xØ25x15.5
15	2	A74162300	Roll bearing 24x18x18	1	1	S414540080	Washer 3 speed
16	1	A94190900	Assy Housing Winch 70.3 Housing W70	1	1	M0604003	Screw M6x12 UNI 5933
	2	S415580085	Bushing Ø12xØ35x9	31	1	S414580081	Shim Bushing 3 speed
	1	S415410081	Bushing 3 speed	32	1	S415400004	Pawls Carrier 3 speed
17	6	M0606303	Screw M8x25 UNI 5931	33	1	S280870041	Gear 1V
18	3	A74147500	Roller Bearing Ø102xØ114x26	34	1	A73129200	ROLLER BEARING 50-62-20
19	1	A94147900	Assy Shaft Winch 70 Central shaft W70 ST	35	1	S377510001	Clutch Spring
	1	S413880002	Washer Ø17.2xØ32x1.5	36	1	A73422600	Bearing 45x55x12
20			Winch Serial Number Sticker	37	1	A94153700	Assy Clutch 3rd speed W70 Assy Command tube W70
21	1	S4155700A0	Stripper arm Housing	1	1	S415420004	Dog Clutch 3 speed
22	1	S281700097	Red line	2	2	M6009463	Spring loaded ball plunger Ø6

*Available with service kit; see website www.harken.com

**Winch product sticker

