

Installation and Maintenance Manual

MRW-01

Powered Radial Winch 70.3 ST E/HY

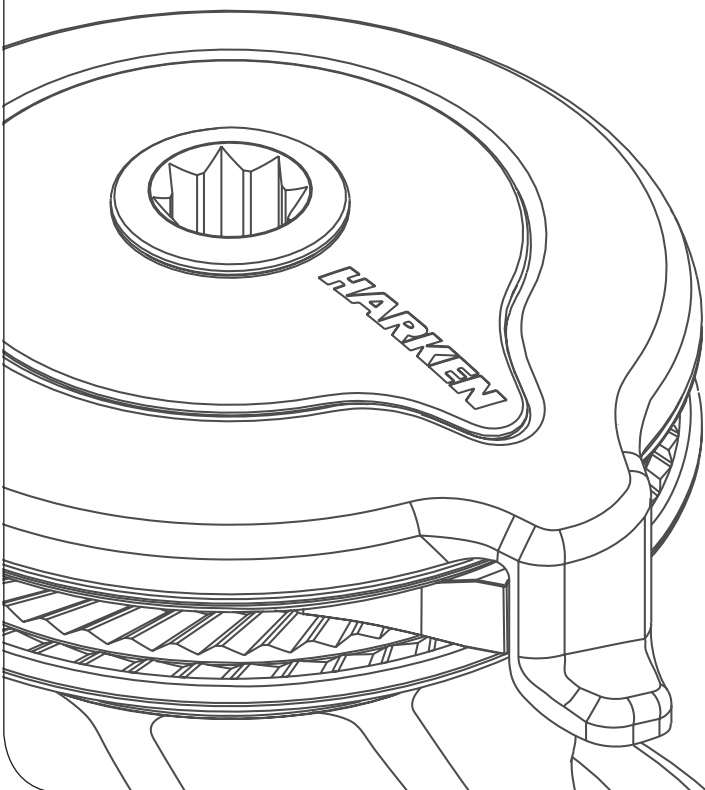

HARKEN[®]

Introduction	3
Technical characteristics	3
<i>Performance data</i>	3
<i>Weight</i>	4
<i>Maximum working load</i>	4
Outline	5
Installation	6
<i>Installation procedure</i>	7
<i>Winch installation procedure</i>	10
<i>Positioning the self-tailing arm</i>	11
Motor installation procedure	11
<i>Electric wiring diagrams</i>	12
<i>Hydraulic connections diagram</i>	15
Maintenance	16
<i>Washing</i>	16
<i>Maintenance table</i>	16
<i>Disassembly procedure</i>	16
<i>Exploded view with maintenance products</i>	20
<i>Assembly</i>	21
Harken® limited worldwide warranty	22
Ordering spare parts	22
Exploded view	23
Parts List	25
<i>Radial Winch 70.3 STA</i>	25
<i>Radial Winch 70.3 STC</i>	26
<i>Radial Winch 70.3 STCW</i>	27
<i>Horizontal electric motor</i>	28
<i>Vertical electric motor</i>	29
<i>Hydraulic motor</i>	30

Introduction

This manual gives technical information on winch installation and maintenance, including disassembling and reassembling.

This information is DESTINED EXCLUSIVELY for specialised personnel or expert users.

Installation, disassembling and reassembling of the winch by personnel who are not experts may cause serious damage to users and those in the vicinity of the winch.

Harken® accepts no responsibility for defective installation or reassembly of its winches.

In case of doubt the Harken® Tech Service is at your disposal at techservice@harken.it

This Manual is available only in English. If you do not fully understand the English language, do not carry out the operations described in this Manual.

Technical characteristics

	Power ratio	Gear ratio
1st speed	9,00 : 1	2,30 : 1
2nd speed	22,20 : 1	5,70 : 1
3rd speed	72,00 : 1	18,50 : 1

The theoretical power ratio does not take friction into account.

Performance data

Winch 70.3 ST E (electric)

	horizontal motor					
	12 V (1500 W)			24 V (2000 W)		
	1st speed	2nd speed	3rd speed	1st speed	2nd speed	3rd speed
line speed (m/min)**	40,0	16,1	5	48,1	19,4	6
max load (Kg)	350	870	2700	350	870	2700

***Line speed is measured with no load*

	vertical motor					
	12 V (1500 W)			24 V (2000 W)		
	1st speed	2nd speed	3rd speed	1st speed	2nd speed	3rd speed
line speed (m/min)**	45,8	18,5	5,7	55,1	22,2	6,9
max load (Kg)	350	870	2700	350	870	2700

***Line speed is measured with no load*

		motor nominal power (W)		current absorption at winch MWL (A)	
		12 V	24 V	12 V	24 V
winch 70.3 ST E	horizontal	1500	2000	275	150
	vertical			265	140

Winch 70.3 ST HY (hydraulic)

	1st speed	2nd speed	3rd speed
line speed (m/min)*	68,4	27,6	8,5
max load (Kg)**	350	870	2700

* at 20 L/min oil flow (5,28 Gal/min)

** at 165 bar at 20 l/min

NOTE

The ratio the line load - pressure are evaluated at flow 20 l/min, at different flow the line load - pressure ratio change and it's minimum at motor stall. The pressure on the graph it's the pressure drop between in and out motor ports. The performance are evaluated measuring the pressure and flow on the motor ports. Performance data based on oli with a viscosity of 35mm²/s [165 SUS] and temperature of 50° [120° F]

Weight

	ST A EH	ST C EH	ST A EV	ST C EV	ST A H	ST C H
weight (Kg)	23,6	27,4	24,3	28,1	20,3	24,1

Versions:

A = drum in anodised aluminium

C = drum in chromed bronze

EH = horizontal electric winch

EV = vertical electric winch

H = vertical hydraulic winch

Maximum working load



WARNING!

The maximum working load (MWL) for the 70.3 ST Radial Winch is 2700 Kg (5952 lb) Subjecting the winch to loads above the maximum working load can cause the winch to fail or pull off the deck suddenly and unexpectedly during high loads causing severe injury or death.

Outline

Winch 70.3 ST E/HY

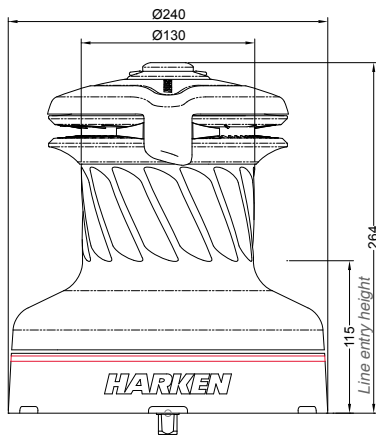

Horizontal electric motor (12 V / 24 V)

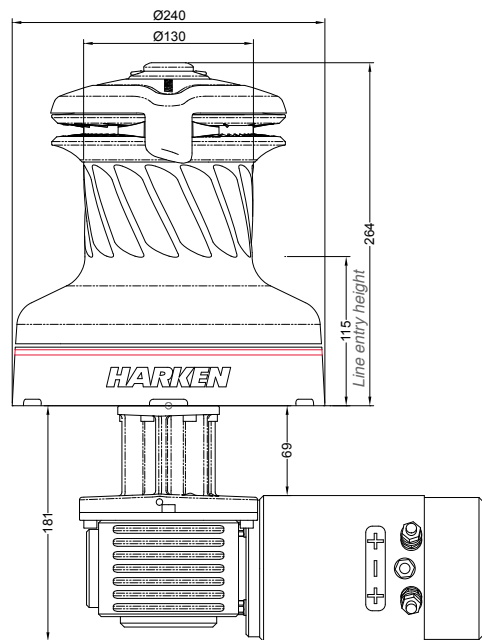

Vertical electric motor (12 V / 24 V)

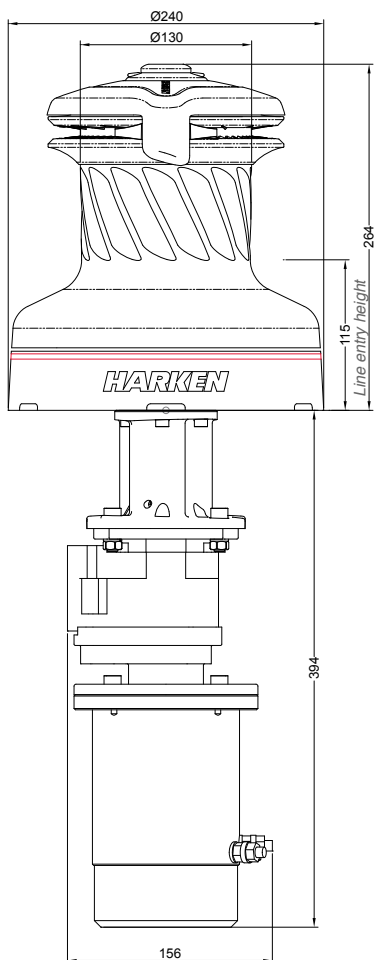

Hydraulic motor

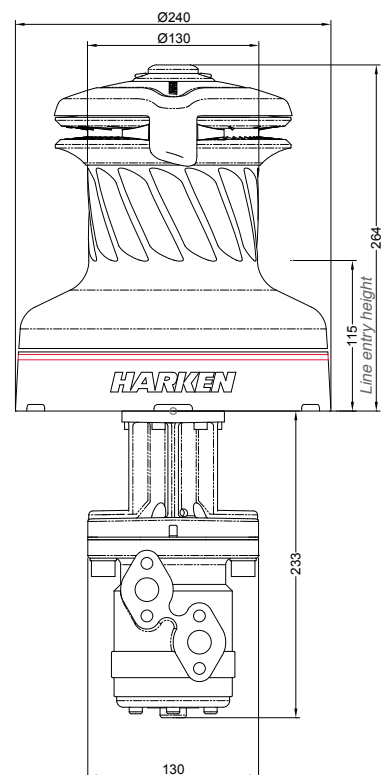

Installation

The winch must be installed on a flat area of the deck, reinforced if necessary to bear a load equal to at least twice the maximum working load of the winch.

It is the installer's responsibility to carry out all structural tests needed to ensure that the deck can bear the load.

Harken® does not supply the screws needed to install the winch since these may vary depending on the deck on which it is to be installed.

It is the installer's responsibility to choose the correct screws taking account of the loads they will have to bear.

Harken® assumes no responsibility for incorrect installation of its winches or for an incorrect choice of mounting screws.



DANGER!

Incorrect installation of the winch may cause severe injury or death. Consult the yard that built the boat in the case of doubt over the correct positioning of the winch.



WARNING!

Failure to use the correct number and type of mounting fasteners or failure to ensure the correct deck strength can result in the winch pulling off the deck suddenly and unexpectedly during high loads causing severe injury or death.



WARNING!

Verify the entry angle of the sheet. This must be 8° with tolerance of $\pm 2^\circ$, to avoid sheet overrides and damaging the winch or making the winch inoperable leading to loss of control of the boat which can lead to severe injury or death.

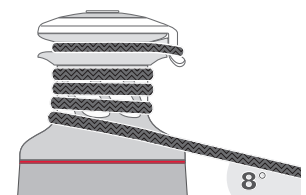

WARNING!

Mount the winch on the deck so that the drive gear is positioned where the sheet enters the winch drum. Incorrect position of drive gear can weaken winch leading to failure which can cause an accident leading to severe injury or death.

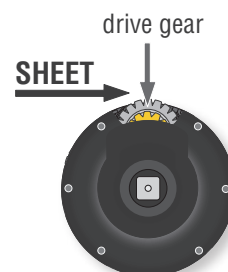

Once you have chosen the correct mounting position for the winch on the deck proceed with installation.

After correctly positioning the final drive gear with respect to the load, check that the motor, gearing, electrical wiring and/or hydraulic pipes can be housed below decks. To help find the optimal compromise, remember that, to make the installation of the motor easier, it can be coupled to the winch in any one of four different positions that differ by 60° from each other.

Once you have decided the correct mounting position for the winch on the deck and checked the space available below deck, proceed with the installation.

Installation procedure

To install the winch you must remove the drum and use Socket Head (SH) bolts.

Tools needed  One medium flat-bladed screwdriver

To identify the various parts, refer to the exploded view at the end of this Manual.

 Torque to apply when assembling



1. Pull out the disconnect rod n°39



2. Unscrew the central screw ($\approx 2\text{Nm}/18\text{ in-lb}$)



3. Slide off the assy socket n°30 and the cover n°29



4. Unscrew the three screws n°28 ($\approx 4\text{Nm}/35\text{ in-lb}$)

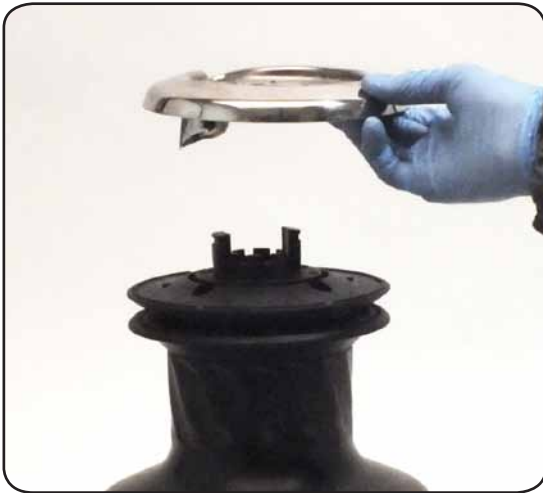

5. Remove the self-tailing arm n°27 by rotating and lifting it.



6. Lift off the drum n°24

Install the winch on the deck in the position you have chosen, keeping in mind the limits described on page 4 and using socket head (SH) bolts.

Follow steps below only to install the winch using hexagonal headed bolts



7. Remove the stripper arm housing n°21



8. Slide out the assy clutch n°38



9. Slide out the central shaft n°19



10. Unscrew the 6 hex screws n°17
($\approx 20\text{Nm}/177\text{ in-lb}$)



11. Remove the drum support n°16

Install the winch on the deck in the position you have chosen, keeping in mind the limits described on page 4 and using hexagonal headed M8 bolts.

Winch installation procedure

Carry out Installation procedure then install the winch on the deck in the chosen position

A. Position the base of the winch on the deck and mark the position of the holes or use the drilling cut-out template at the point where you have decided to place the winch.

Below is a reduced scale diagram.

The drilling cut out template is available on the Harken® website, www.harken.com

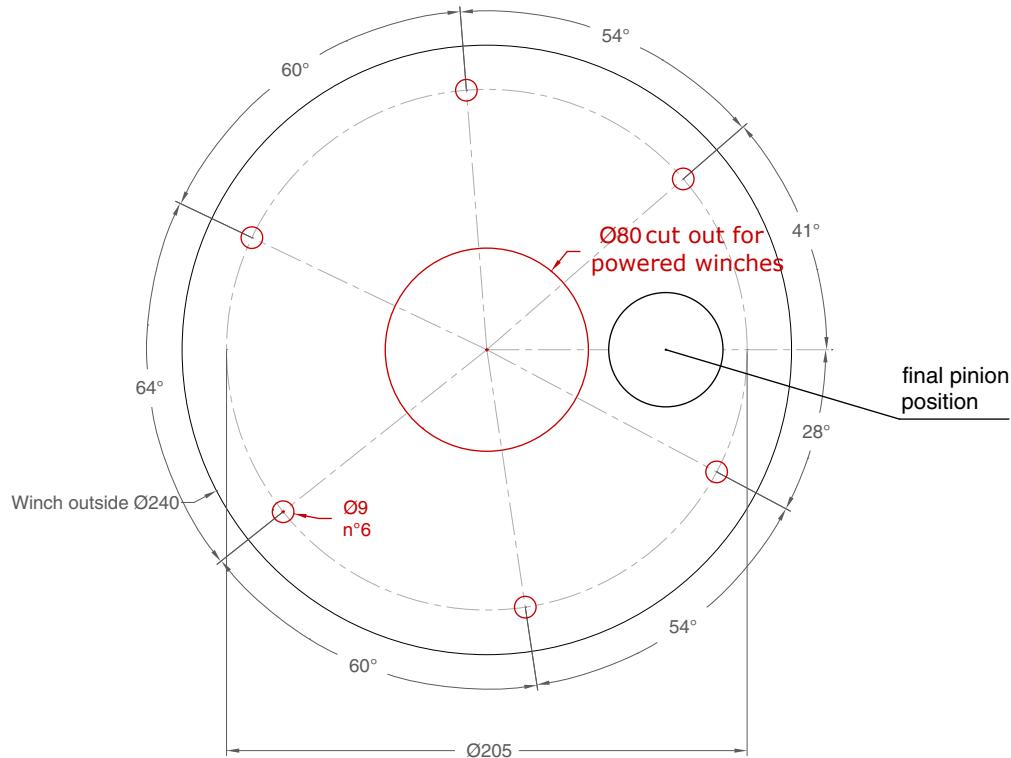

B. Remove the winch and drill the six 9 mm and a 80 mm diameter holes.

C. Bolt the base of the winch to the deck using six M8 Socket Head (SH) bolts or six hexagonal headed M8 bolts (neither is supplied by Harken®), correctly chosen for the thickness and type of the boat deck. Consult the yard that built the boat in case of doubt.



WARNING!

To install the winch on the deck, use only bolts in A4 stainless steel (DIN 267 part 11). Bolts made of other materials may not have sufficient strength or may corrode which can result in winch pulling off deck suddenly and unexpectedly during high loads causing severe injury or death.

NOTICE

To mount winches on the deck, do not use countersunk bolts.

D. Fill the mounting holes with a suitable marine sealant.

E. Remove the excess adhesive/sealant from the holes and base drainage channels

F. Reassemble the winch following the steps in Installation procedure (page 7) in the reverse order, and apply the products indicated in the section on maintenance.

NOTICE

Before closing the winch, make sure the holes and drainage channels in the base of the winch are not obstructed.





Positioning the self-tailing arm

Position the self-tailing arm so that the line leaving the winch is led into the cockpit.

Motor installation procedure

Once you have installed the winch on the deck, proceed with motor installation. The motor can be coupled to the winch in different positions. Check the space available below deck and choose the suitable position.

Tools needed

-  A number five hex key
-  A number six hex key (only for vertical electric motor)
-  A number ten hex key (only for hydraulic motor)
-  Two number thirteen wrenches



1. Position the flange (see Page 12)



2. Tighten the six screws (⚙️ 8 Nm/ 71 in-lb)



3. Position the reduction gear and motor



4. Tighten the two screws (⚙️ 8 Nm/ 71 in-lb).
Be sure to align the flange.

NOTICE

Before positioning the flange, check to make sure that seals (the first one is above the flange and the second one is under the flange) are seated correctly.



After winch is assembled and before sailing, test the powered winch functioning: insert the lock-in winch handle in the handle socket and check that the disconnect rod must disconnect gearbox.

Electric wiring diagrams

To guarantee greater efficiency in terms of safety and long life, for certain winch models it is obligatory to install the WLC200R Load Controller.



WARNING!

Consult the table below to check for which winch models it is obligatory to install the WLC200R and for which it is recommended.

WINCH RADIAL	Horizontal motor		Vertical motor	
	12 V	24 V	12 V	24 V
70.3	recommended	obligatory	obligatory	obligatory

For more information, refer to the WLC200R Manual.

Refer to the following diagrams for the electric wiring:

Horizontal 12 V / 24 V motor installed without WLC200R

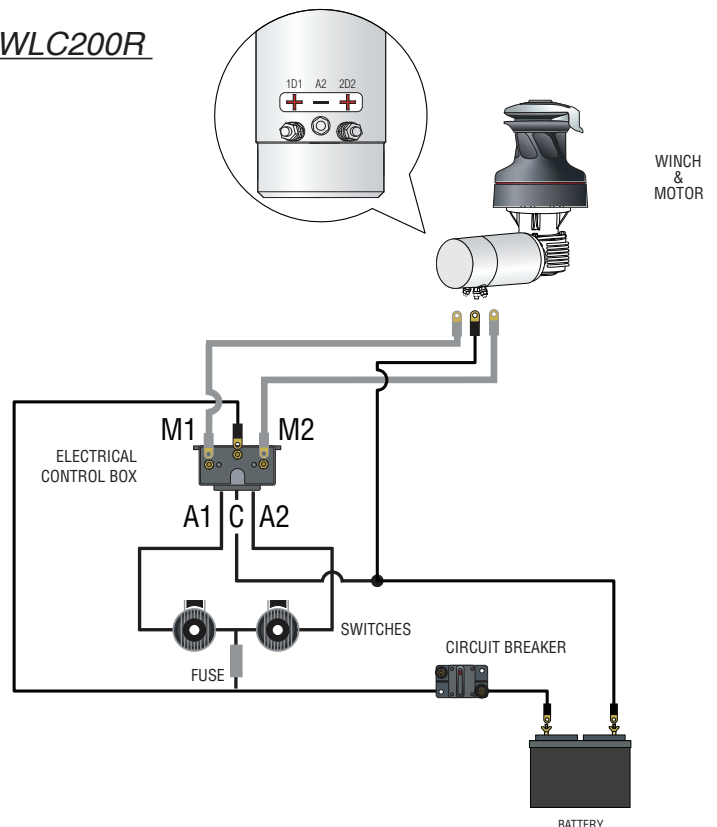

Horizontal 12 V / 24 V motor in right-hand configuration installed with WLC200R

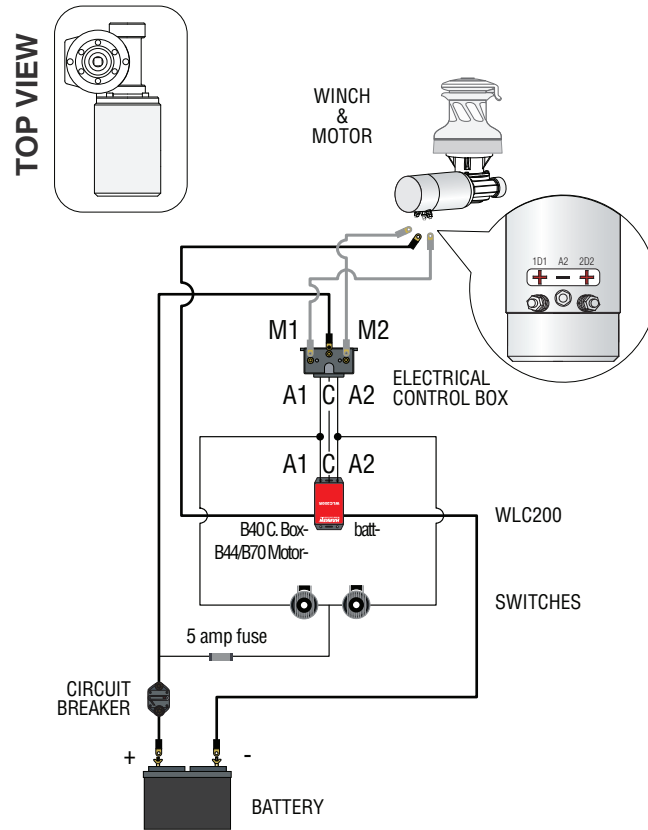

Horizontal 12/24V motor in left-hand configuration and vertical 12/24V motor installed with WLC200R

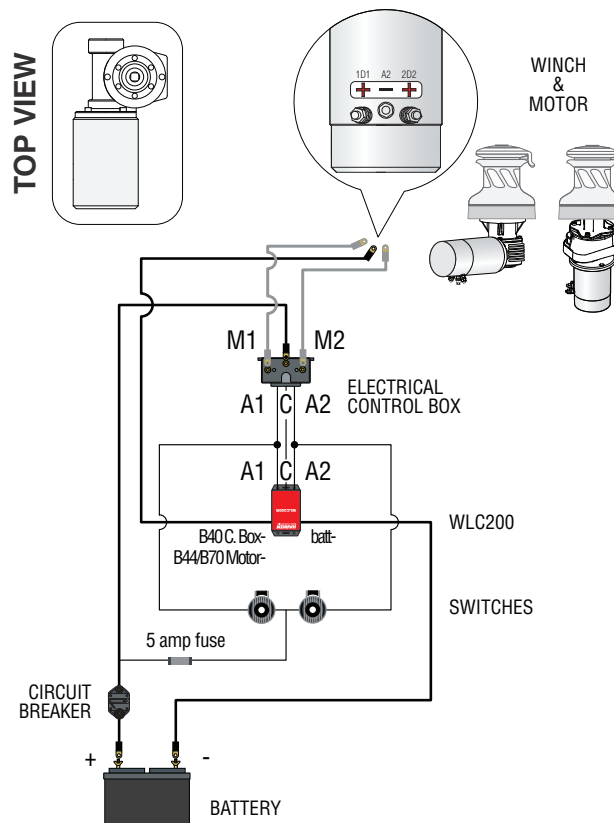

Fasten electric control box containing solenoids to bulkhead or wall. Install remote circuit breaker between power supply and electric control box. Locate push-buttons on deck in a convenient spot for easy winch operation.

Refer to the following chart for wire size:

Total distance between winch and battery

Winch size	Current voltage	Under 16.4 ft AWG	Under 5 m mm ²	16.4 - 32.8 ft AWG	5 m - 10 m mm ²	32.8 - 49.2 ft AWG	10 m - 15 m mm ²	49.2 - 65.6 ft AGW	15m - 20 m mm ²
70.3	12 V	2	32	0	50	00	70	000	95
70.3	24 V	5	16	3	25	2	35	0	50

NOTICE

To connect motor, attach cable terminals to clamps between nut and lock nut. Hold nut in contact with motor using a spanner and tighten other nut with second spanner. Take special care not to turn the central spindles. Be careful not to turn central spindles. These instructions apply when assembling and disassembling. We recommend using a torque wrench so as to obtain a torque equal to and no greater than 10 Nm (88 in-lb).



NOTICE

Note that correct electrical contact sequence is:
Nut – Cable Terminal – Self-Locking Washer – Lock Nut



Hydraulic connections diagram

The hydraulic motor must be connected to a hydraulic system using two high-pressure tubes which serve for input or output according to the direction in which the motor will be run. The motor also needs a third connection with a low pressure tube for drainage, so that excess oil can return to the main tank to avoid shortening the life of the motor. This motor uses an open centre valve.

Refer to the following chart for the hydraulic system:

For the hydraulic motor:

Input/output pipe thread: G 1/2 – depth 15 mm

Drainage pipe thread: G 1/4 – depth 12 mm

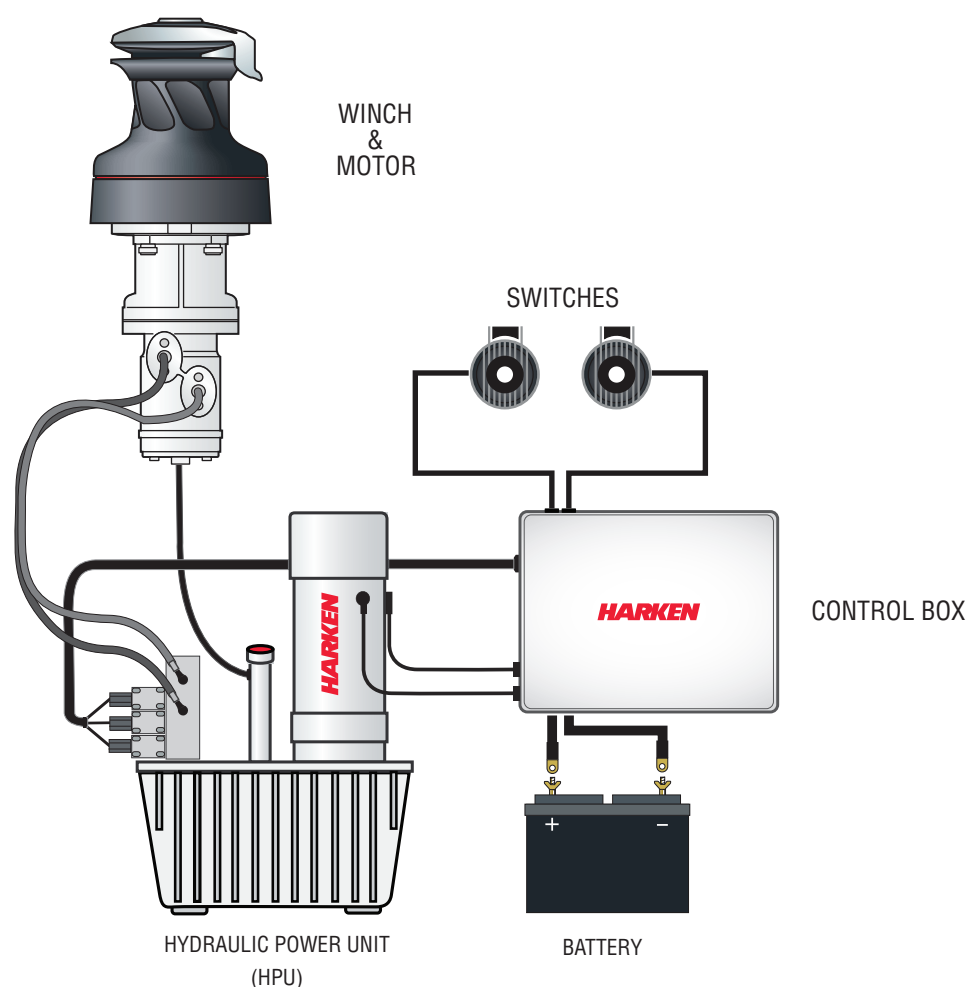

Maintenance

Washing

Winches must be washed frequently with fresh water, and in any case after each use.

Do not allow teak cleaning products or other cleaners containing caustic solutions to come into contact with winches and especially anodised, chrome plated or plastic parts.

Do not use solvents, polishes or abrasive pastes on the logos or stickers on the winches. Do not use polishes or abrasive pastes on anodised, chromed plated or plastics surfaces.

Make sure that the holes and drainage channels in the base of the winch are not obstructed so that water does not collect.

Maintenance table

Winches must be visually inspected at the beginning and end of every season of sailing or racing. In addition they must be completely overhauled, cleaned and lubricated at least every 12 months. After an inspection, replace worn or damaged components. Do not replace or modify any part of the winch with a part that is not original.



WARNING!

Periodic maintenance must be carried out regularly. Lack of adequate maintenance shortens the life of the winch, can cause serious injury and also invalidate the winch warranty. Installation and maintenance of winches must be carried out exclusively by specialized personnel.

In the case of doubt contact Harken® Tech Service at techservice@harken.it

Disassembly procedure

Tools needed:



One medium flat-bladed screwdriver



A number six hex key



Brush



Rags

To identify the various parts refer to the exploded view at the end of this Manual.

 Torque to be applied in assembly phase

Carry out **Installation procedure** (page 7) as shown in the paragraph on winch installation and then do the following:



7. Remove the stripper arm housing n°21



8. Slide out the assy clutch n°38

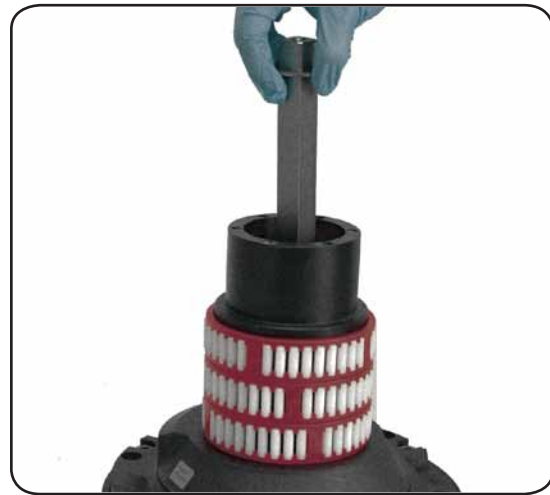

9. Slide out the central shaft n°19



10. Unscrew the 6 hex screws n°17
($\approx 20\text{Nm}/177\text{ in-lb}$)



11. Slide out the drum support n°16



12. Remove the gear n°34, pawls carrier n°33, the bearings n°35 and 37 and the pin n°36

Important: washer n°7 may remain inside the drum support!



13. Remove the gear n°6, pawls carrier n°3 and the washer n°7



14. Remove the idler and pinion n°14



15. Remove the pawl carrier n°11



16. Remove gear n°10



17. Remove the gear n°2



18. Remove the roller bearing n°12



18. Remove roller bearings n°15

If it is necessary to replace any jaws of the winch, proceed as follows:



I. Unscrew the 4 screws n°28
($\approx 4\text{Nm}/35\text{ in-lb}$)



II. Remove the jaws n°23

Inspect balls inside the drum and carefully check the correct position; if it is necessary to put back any balls, push balls in the race (as shown below):



Once the winch is completely disassembled, clean the parts: use a basin of diesel oil to soak metal components and rinse plastic parts in fresh water. Once you have done this, dry the parts with cloths that do not leave residue.

Inspect gears, bearings, pins and pawls for any signs of wear or corrosion.

Carefully check the teeth of gears and ring gears to make sure there are no traces of wear.

Check the roller bearings and check there are no breaks in the bearing cages.

Replace worn or damaged components.

Carry out maintenance on components using the products listed below.

For more information on which products to use where, refer to the exploded diagram below.

Use a brush to lightly lubricate all gears, gear pins, teeth and all moving parts with grease.

Lightly lubricate the pawls and springs with oil. Do not use grease on the pawls!

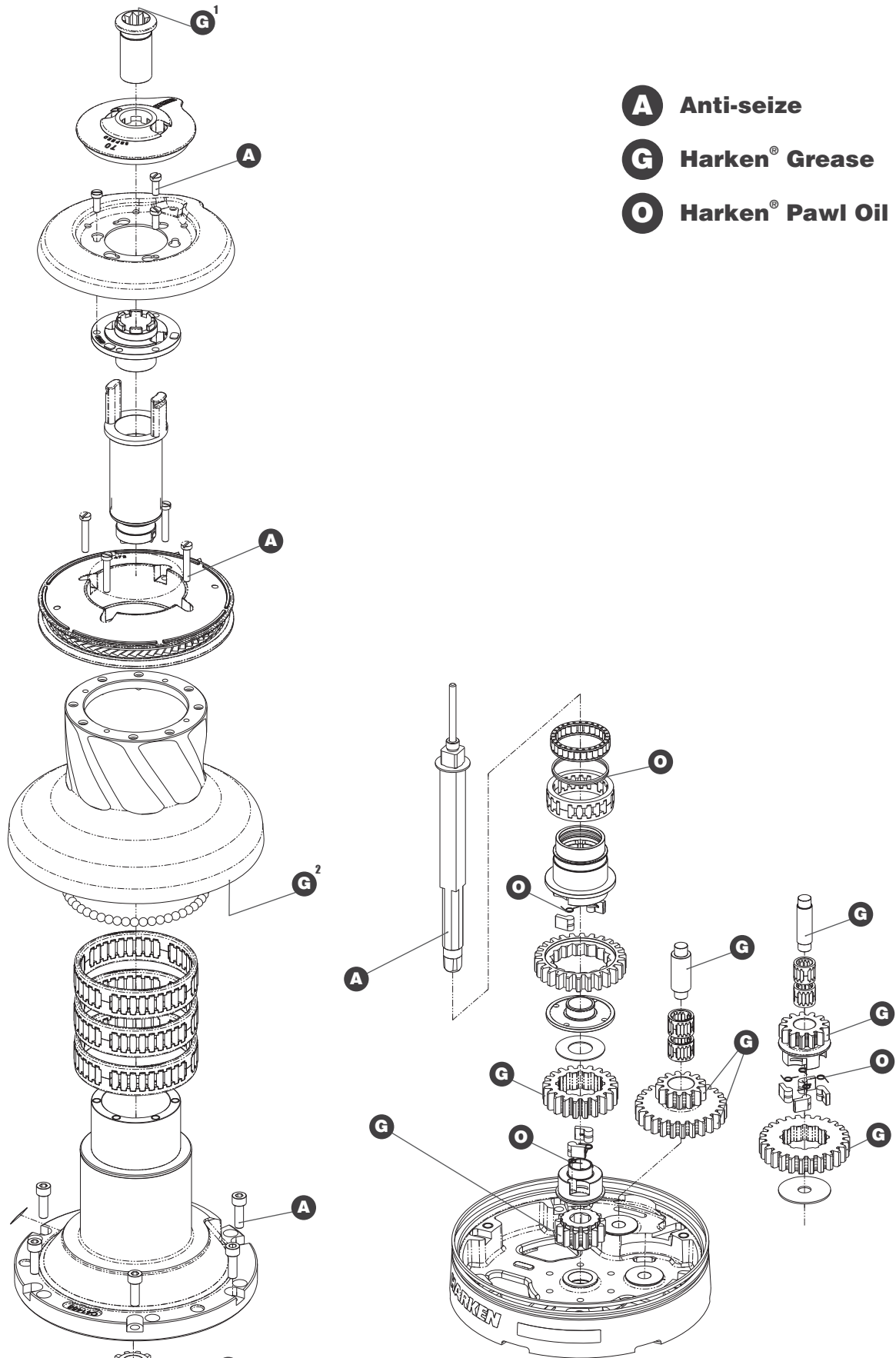
Exploded view with maintenance products

1. Apply Harken® grease on assy socket screw - 2. Apply Harken® grease on drum gear

Assembly

Make sure that the holes and drainage channels in the base of the winch are not obstructed. Assemble the winch in the reverse order of the sequence in the section on disassembly.

To tighten bolts, use the torque indicated in the disassembly procedure.



The icon ▲ on the Stripper Arm Housing indicates the Stripper Arm final position. Change the Stripper Arm Housing angle to modify the Stripper Arm final position.

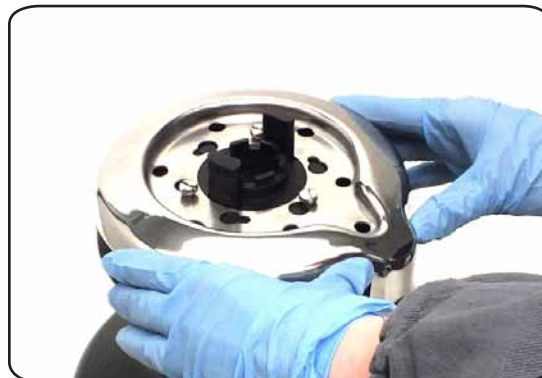

When positioning the stripper arm, align the peeler with it. If the jaws have been disassembled, insert peeler between the two jaws, taking care that the letters TOP on the peeler are facing upwards.

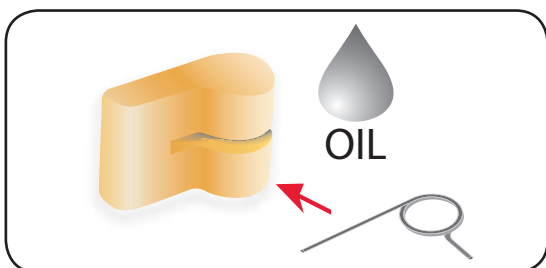

To assemble the pawls

Correctly position the spring in its housing as shown at left. Hold the spring closed and slide the pawl into its housing. Once in position, check that the pawls can be easily opened and closed with a finger.

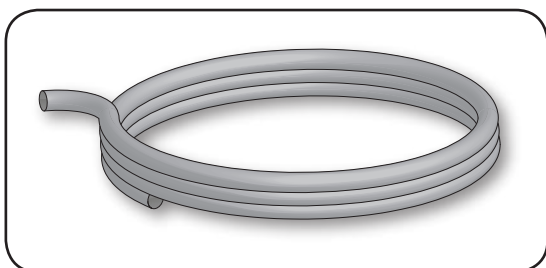

To assemble the clutch pin

Mount the spring with the pin pointing upwards so that it is wound in an anti-clockwise direction starting from the pin.

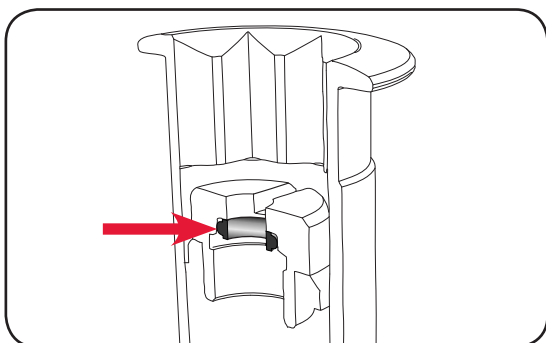

NOTICE

Before screw the central screw, check the correct position of the o-ring in the assy socket.

In case of doubt concerning the assembly procedure contact Harken® Tech Service: techservice@harken.it

Harken® limited worldwide warranty

Refer to the Harken® Limited Worldwide Warranty in the Harken® Catalogue and on the website www.harken.com

Ordering spare parts

Spare parts can be requested from Harken® as described in the Harken® Limited Worldwide Warranty, indicating the part number in the Parts List and including the serial number of the winch for which the parts are required.

The serial number of the winch is printed on a plate on the drum support of the winch.

**Manufacturer*****Harken® Italy S.p.A.***

Via Marco Biagi, 14
22070 Limido Comasco (CO) Italy
Tel: (+39) 031.3523511
Fax: (+39) 031.3520031
Email: info@harken.it
Web: www.harken.com

- **Tech Service**
Email: techservice@harken.it
- **Customer Service**
Tel: (+39) 031.3523511
Email: info@harken.it

Headquarters***Harken®, Inc.***

1251 East Wisconsin Avenue
Pewaukee, Wisconsin 53072-3755 USA
Tel: (262) 691.3320
Fax: (262) 691.3008
Email: harken@harken.com
Web: www.harken.com

- **Tech Service**
Email: technicalservice@harken.com
- **Customer Service**
Tel: (262) 691-3320
Email: customerservice@harken.com

Exploded view

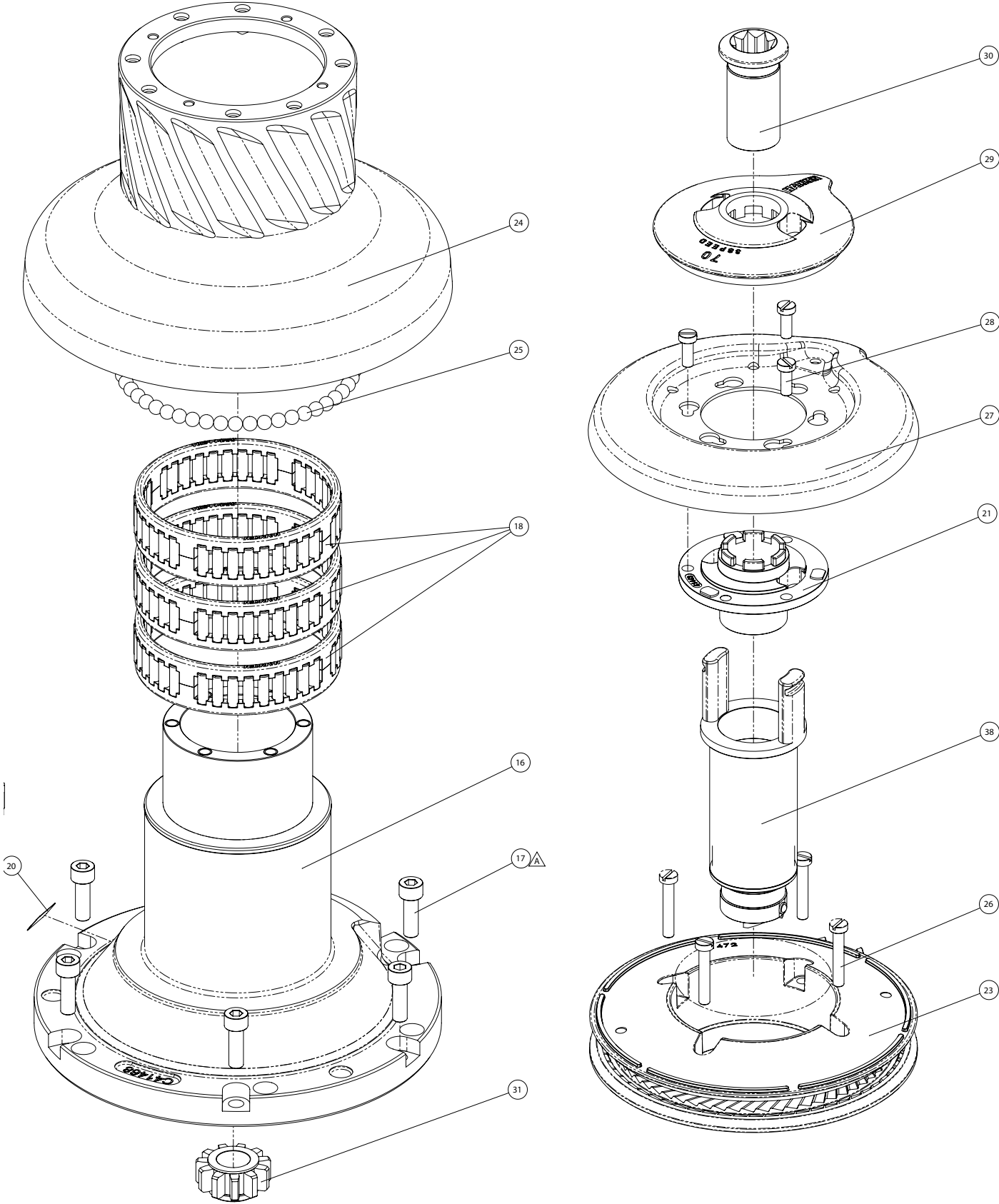

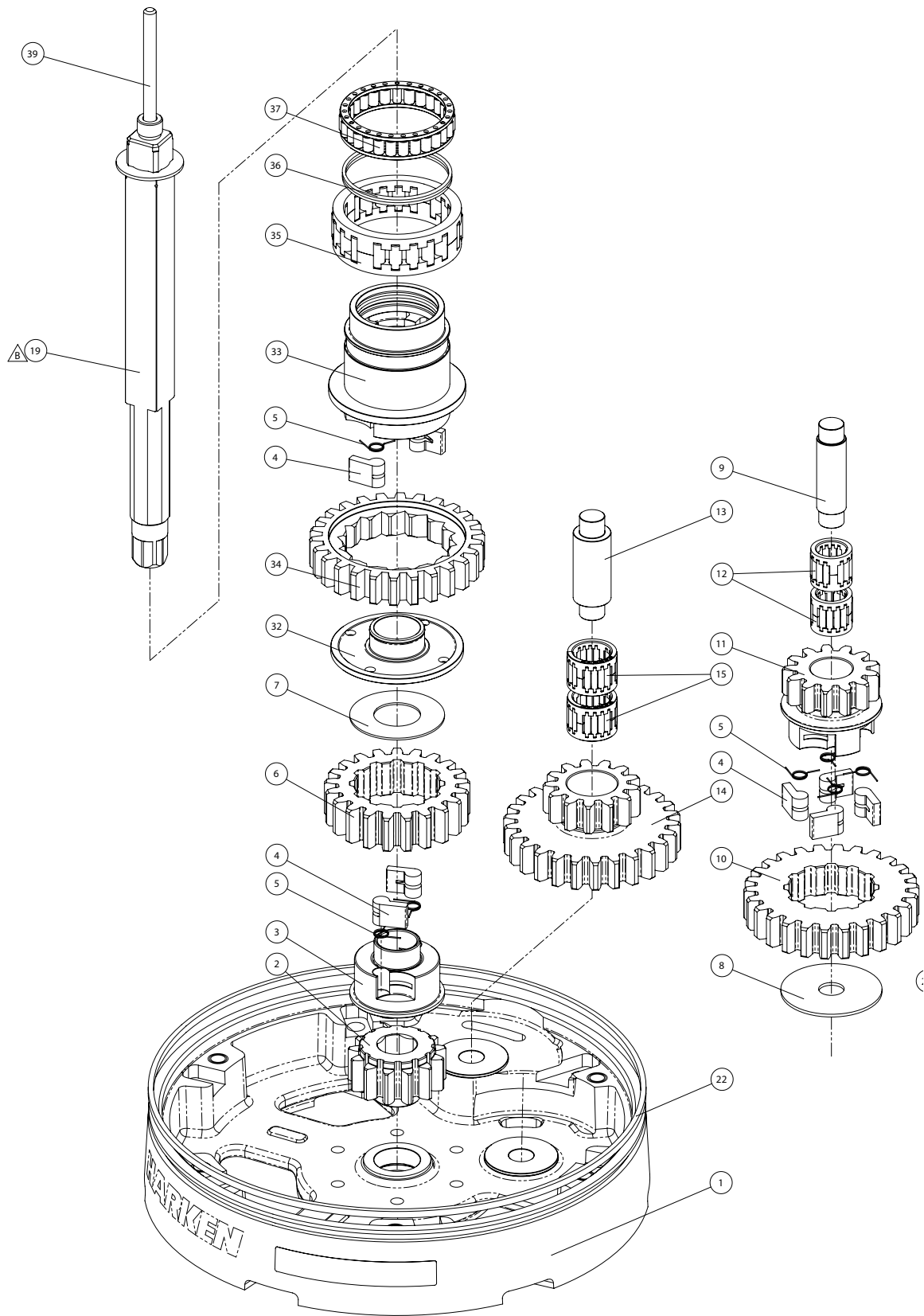

Parts List

Radial Winch 70.3 STA

A= drum in anodised aluminium

Pos.	Q.ty	Code	Description	Pos.	Q.ty	Code	Description
1	1	A 941900 00	Assy Base Winch 70 EL/HY Base W70 Heli-coil M8x10 Centering bushing Ø12 Bushing Ø22xØ25x8.5* Bushing Ø12xØ35x9* Winch Product Sticker**	22	1	S 28170 00 97	Red line*
2	1	S 41477 00 04	Gear Z13 W70	23	1	A 941471 00	Assy Jaws winch 70 Lower Jaw W70 Upper Jaw W70 Peeler W60 - 70 Spring
3	1	S 41303 00 04	Pawls Carrier Ø8xN2	24	1	A 741469 00	Assy Drum Winch 70
4	8	S 00008 00 03	Pawl Ø8	25	50	M 06102 80	Ball 5/16" *
5	8	S 00038 00 01	Pawl Spring Ø8	26	4	M0601803	Screw UNI EN ISO 1207:1996 - M6x35 - A4*
6	1	S 41439 00 41	Rachet Gear Z21xN2	27	1	S 41473 00 19	Stripper Arm W70
7	1	S 41312 00 02	Washer Ø22.5xØ45x1*	28	3	M0601903	Screw M6x16 UNI1207*
8	1	S278170002	Washer 12.5x48x1.5*	29	1	S 41555 00 B1	Cover 3 speed W70
9	1	S 28101 00 04	Pin for gear	30	1	A 941914 00	Assy Socket Handle Winch 3spd EL/HY Socket Handle 3 speed Washer ø25xø15x4 Nut Screw for Disconnect Rod O ring RC 2025 series*
10	1	S 41442 00 41	Rachet Gear Z26xN4	31	1	A 941453 00	Assy Gear 3rd speed Idler Gear 3 speed Bushing Ø22/Ø25x15.5 Washer 3 speed Screw M6x12 UNI 5933
11	1	S 41441 00 04	Pawls Carrier Gear Z13 N4	32	1	S 41458 00 81	Shim Bushing 3 speed*
12	2	A72821800	Roller Bearing 14/20/18	33	1	S 41540 00 04	Pawls Carrier 3 speed
13	1	S 41603 00 04	Gear Pin Ø12xØ18x52,5	34	1	S280870041	Gear 1V
14	1	S 41476 00 04	Idler and Pinion Z26/Z13 W70	35	1	A73129200	Roller Bearing 50-62-20 Erta P*
15	2	A 741623 00	Roll bearing 24x18x18	36	1	S 37751 00 01	Clutch Spring
16	1	A 941909 00	Assy Housing Winch 70.3 Housing W70 Bushing Ø12xØ35x9* Heli-coil M6x9 Bushing 3 speed	37	1	A73422600	Bearing 45x55x12*
17	6	M0606303	Screw M8x25 UNI 5931	38	1	A 941537 00	Assy Clutch 3rd spd W70 Assy Command tube W70 Dog Clutch 3 speed Spring loaded ball plunger Ø6
18	3	A 741475 00	Roller Bearing Ø102xØ114x26*	39	1	S 41903 00 02	Disconnect rod W70.3
19	1	A 967535 00	Assy Shaft Winch 70 EL/HY Central Shaft Pred. W70 Washer Ø17.2xØ32x1.5				
20	1	S 41876 00 63	Winch Serial Number Sticker				
21	1	S 41557 00 A0	Stripper arm support				

*Service kit available; see winch kit section on the website www.harken.com

**Winch product sticker



Radial Winch 70.3 STC

C=drum in chromed bronze

Pos.	Q.ty	Code	Description	Pos.	Q.ty	Code	Description
1	1	A 941900 00	Assy Base Winch 70 EL/HY Base W70 Heli-coil M8x10 Centering bushing Ø12 Bushing Ø22xØ25x8.5* Bushing Ø12xØ35x9* Winch Product Sticker**	22	1	S 28170 00 97	Red line*
2	1	S 41477 00 04	Gear Z13 W70	23	1	A 941471 00	Assy Jaws winch 70 Lower Jaw W70 Upper Jaw W70 Peeler W60 - 70 Spring
3	1	S 41303 00 04	Pawls Carrier Ø8xN2	24	1	A 741488 00	Assy Drum Winch 70
4	8	S 00008 00 03	Pawl Ø8	25	50	M 06102 80	Ball 5/16" *
5	8	S 00038 00 01	Pawl Spring Ø8	26	4	M0601803	Screw UNI EN ISO 1207:1996 - M6x35 - A4*
6	1	S 41439 00 41	Rachet Gear Z21xN2	27	1	S 41473 00 19	Stripper Arm W70
7	1	S 41312 00 02	Washer Ø22.5xØ45x1*	28	3	M0601903	Screw M6x16 UNI1207*
8	1	S278170002	Washer 12.5x48x1.5*	29	1	S 41555 00 B1	Cover 3 speed W70
9	1	S 28101 00 04	Pin for gear	30	1	A 941914 00	Assy Socket Handle Winch 3spd EL/HY Socket Handle 3 speed Washer ø25xø15x4 Nut Screw for Disconnect Rod O ring RC 2025 series*
10	1	S 41442 00 41	Rachet Gear Z26xN4	31	1	A 941453 00	Assy Gear 3rd speed Idler Gear 3 speed Bushing Ø22/Ø25x15.5 Washer 3 speed Screw M6x12 UNI 5933
11	1	S 41441 00 04	Pawls Carrier Gear Z13 N4	32	1	S 41458 00 81	Shim Bushing 3 speed*
12	2	A72821800	Roller Bearing 14/20/18	33	1	S 41540 00 04	Pawls Carrier 3 speed
13	1	S 41603 00 04	Gear Pin Ø12xØ18x52,5	34	1	S280870041	Gear 1V
14	1	S 41476 00 04	Idler and Pinion Z26/Z13 W70	35	1	A73129200	Roller Bearing 50-62-20 Erta P*
15	2	A 741623 00	Roll bearing 24x18x18	36	1	S 37751 00 01	Clutch Spring
16	1	A 941909 00	Assy Housing Winch 70.3 Housing W70 Bushing Ø12xØ35x9* Heli-coil M6x9 Bushing 3 speed	37	1	A73422600	Bearing 45x55x12*
17	6	M0606303	Screw M8x25 UNI 5931	38	1	A 941537 00	Assy Clutch 3rd spd W70 Assy Command tube W70 Dog Clutch 3 speed Spring loaded ball plunger Ø6
18	3	A 741475 00	Roller Bearing Ø102xØ114x26*	39	1	S 41903 00 02	Disconnect rod W70.3
19	1	A 967535 00	Assy Shaft Winch 70 EL/HY Central Shaft Pred. W70 Washer Ø17.2xØ32x1.5				
20	1	S 41876 00 63	Winch Serial Number Sticker				
21	1	S 41557 00 A0	Stripper arm support				

*Service kit available; see winch kit section on the website www.harken.com

**Winch product sticker



Radial Winch 70.3 STCW

C=drum in chromed bronze W=components RAL 9003

Pos.	Q.ty	Code	Description	Pos.	Q.ty	Code	Description
1	1	A 967258 00 W	Assy Base Winch 70 RAL 9003 <i>Base W70 RAL 9003 Skirt W70 RAL 9003 Heli-coil M8x10 Centering bushing Ø12 Bushing Ø22xØ25x9.5* Bushing Ø12xØ35x9* Winch Product Sticker**</i>	22	1	S 28170 00 97	Red line*
2	1	S 41477 00 04	Gear Z13 W70	23	1	A 941471 00 W	Assy Jaws winch 70 <i>Lower Jaw W70 RAL 9003 Upper Jaw W70 RAL 9003 Peeler W60 - 70 RAL 9003 Spring</i>
3	1	S 41303 00 04	Pawls Carrier Ø8xN2	24	1	A 741488 00	Assy Drum Winch 70
4	8	S 00008 00 03	Pawl Ø8	25	50	M 06102 80	Ball 5/16" *
5	8	S 00038 00 01	Pawl Spring Ø8	26	4	M0601803	Screw UNI EN ISO 1207:1996 - M6x35 - A4*
6	1	S 41439 00 41	Rachet Gear Z21xN2	27	1	S 41473 00 19	Stripper Arm W70
7	1	S 41312 00 02	Washer Ø22.5xØ45x1*	28	3	M0601903	Screw M6x16 UNI1207*
8	1	S278170002	Washer 12.5x48x1.5*	29	1	S 41555 00 B1 W	Cover 3 speed W70 RAL 9003
9	1	S 28101 00 04	Pin for gear	30	1	A 941914 00	Assy Socket Handle Winch 3spd EL/HY <i>Socket Handle 3 speed Washer ø25xø15x4 Nut Screw for Disconnect Rod O ring RC 2025 series*</i>
10	1	S 41442 00 41	Rachet Gear Z26xN4	31	1	A 941453 00	Assy Gear 3rd speed <i>Idler Gear 3 speed Bushing Ø22/Ø25x15.5 Washer 3 speed Screw M6x12 UNI 5933</i>
11	1	S 41441 00 04	Pawls Carrier Gear Z13 N4	32	1	S 41458 00 81	Shim Bushing 3 speed*
12	2	A72821800	Roller Bearing 14/20/18	33	1	S 41540 00 04	Pawls Carrier 3 speed
13	1	S 41603 00 04	Gear Pin Ø12xØ18x52,5	34	1	S280870041	Gear 1V
14	1	S 41476 00 04	Idler and Pinion Z26/Z13 W70	35	1	A73129200	Roller Bearing 50-62-20 Erta P*
15	2	A 741623 00	Roll bearing 24x18x18	36	1	S 37751 00 01	Clutch Spring
16	1	A 941909 00	Assy Housing Winch 70.3 <i>Housing W70 Bushing Ø12xØ35x9* Heli-coil M6x9 Bushing 3 speed</i>	37	1	A73422600	Bearing 45x55x12*
17	6	M0606303	Screw M8x25 UNI 5931	38	1	A 941537 00	Assy Clutch 3rd spd W70 <i>Assy Command tube W70 Dog Clutch 3 speed Spring loaded ball plunger Ø6</i>
18	3	A 741475 00	Roller Bearing Ø102xØ114x26*	39	1	S 41903 00 02	Disconnect rod W70.3
19	1	A 967535 00	Assy Shaft Winch 70 EL/HY <i>Central Shaft Pred. W70 Washer Ø17.2xØ32x1.5</i>				
20	1	S 41876 00 63	Winch Serial Number Sticker				
21	1	S 41557 00 A0	Stripper arm support				

*Service kit available; see winch kit section on the website www.harken.com

**Winch product sticker



Horizontal electric motor

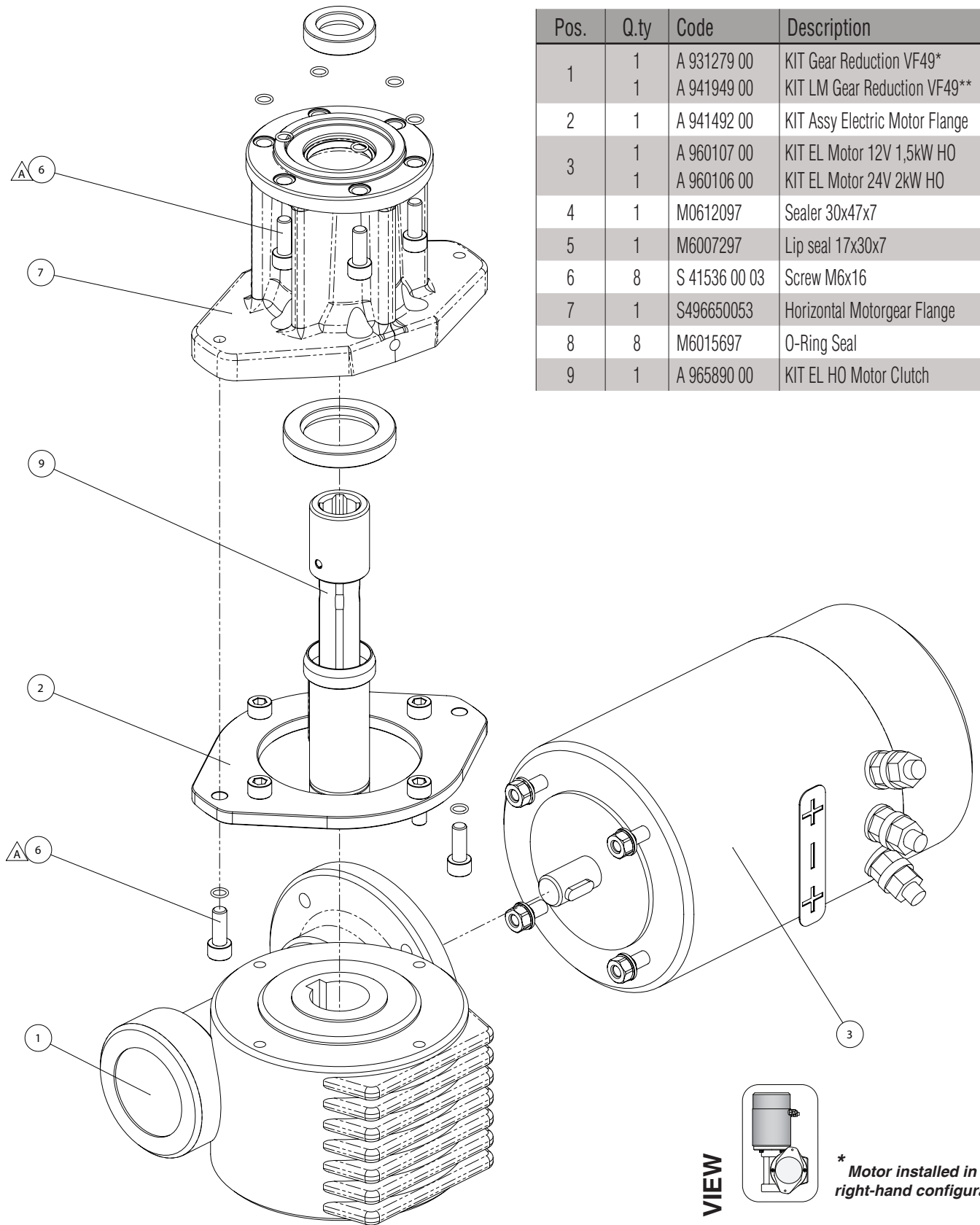

Pos.	Q.ty	Code	Description
1	1	A 931279 00	KIT Gear Reduction VF49*
	1	A 941949 00	KIT LM Gear Reduction VF49**
2	1	A 941492 00	KIT Assy Electric Motor Flange
3	1	A 960107 00	KIT EL Motor 12V 1,5kW HO
	1	A 960106 00	KIT EL Motor 24V 2kW HO
4	1	M0612097	Sealer 30x47x7
5	1	M6007297	Lip seal 17x30x7
6	8	S 41536 00 03	Screw M6x16
7	1	S496650053	Horizontal Motorgear Flange
8	8	M6015697	O-Ring Seal
9	1	A 965890 00	KIT EL HO Motor Clutch

TOP VIEW

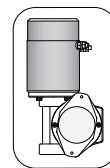

* Motor installed in right-hand configuration.

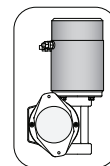

** Motor installed in left-hand configuration.

Vertical electric motor

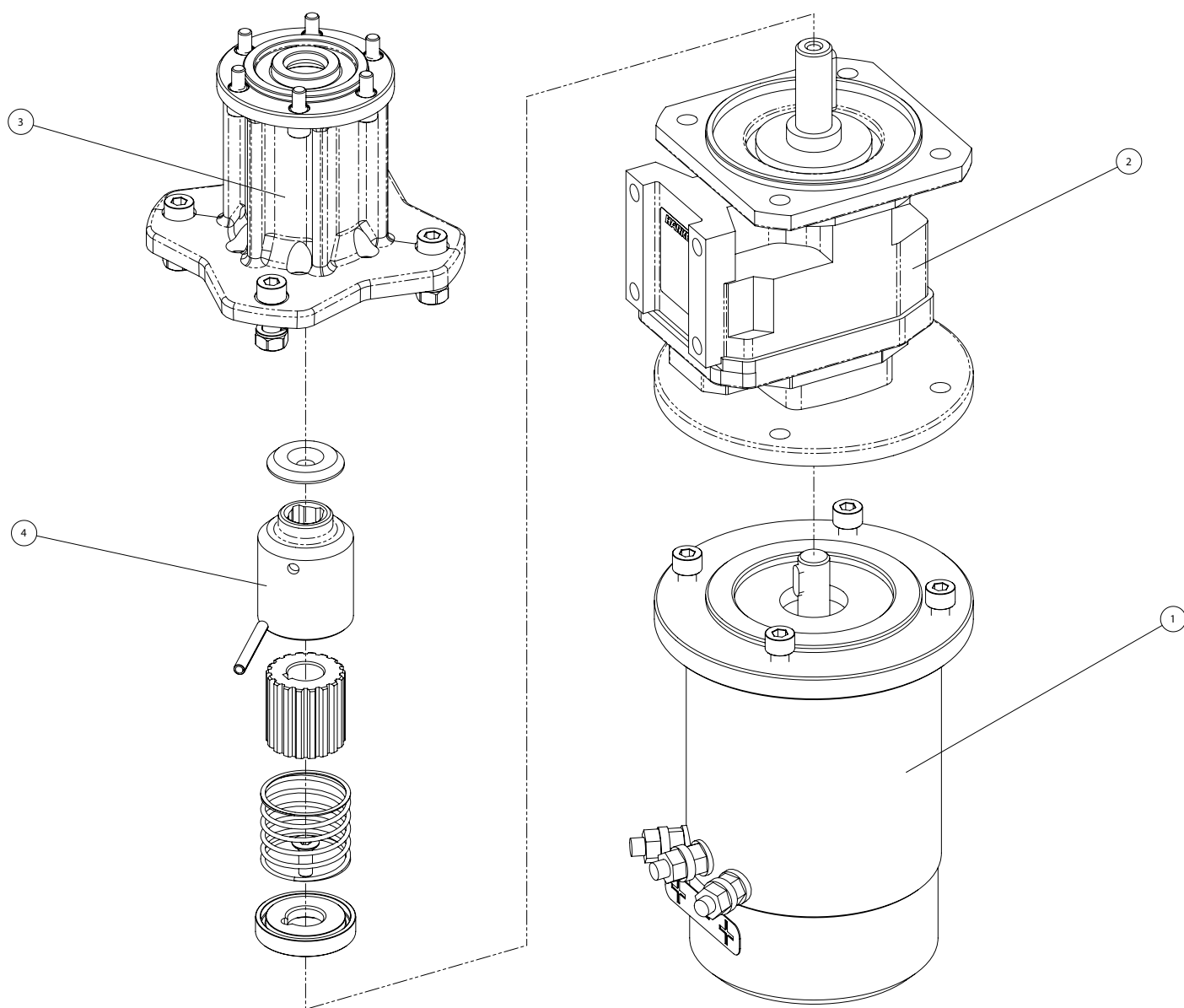

Pos.	Q.ty	Code	Description
1	1	A 960105 00	KIT EL Motor 12V 1,5kW VT
	1	A 960104 00	KIT EL Motor 24V 2kW VT
2	1	A 965629 00	Vertical reduction gear box STM AMF1 35
3	1	A 941505 00	KIT EL VT Motor Flange
4	1	A 941937 00	KIT EL VT Motor Clutch

Hydraulic motor

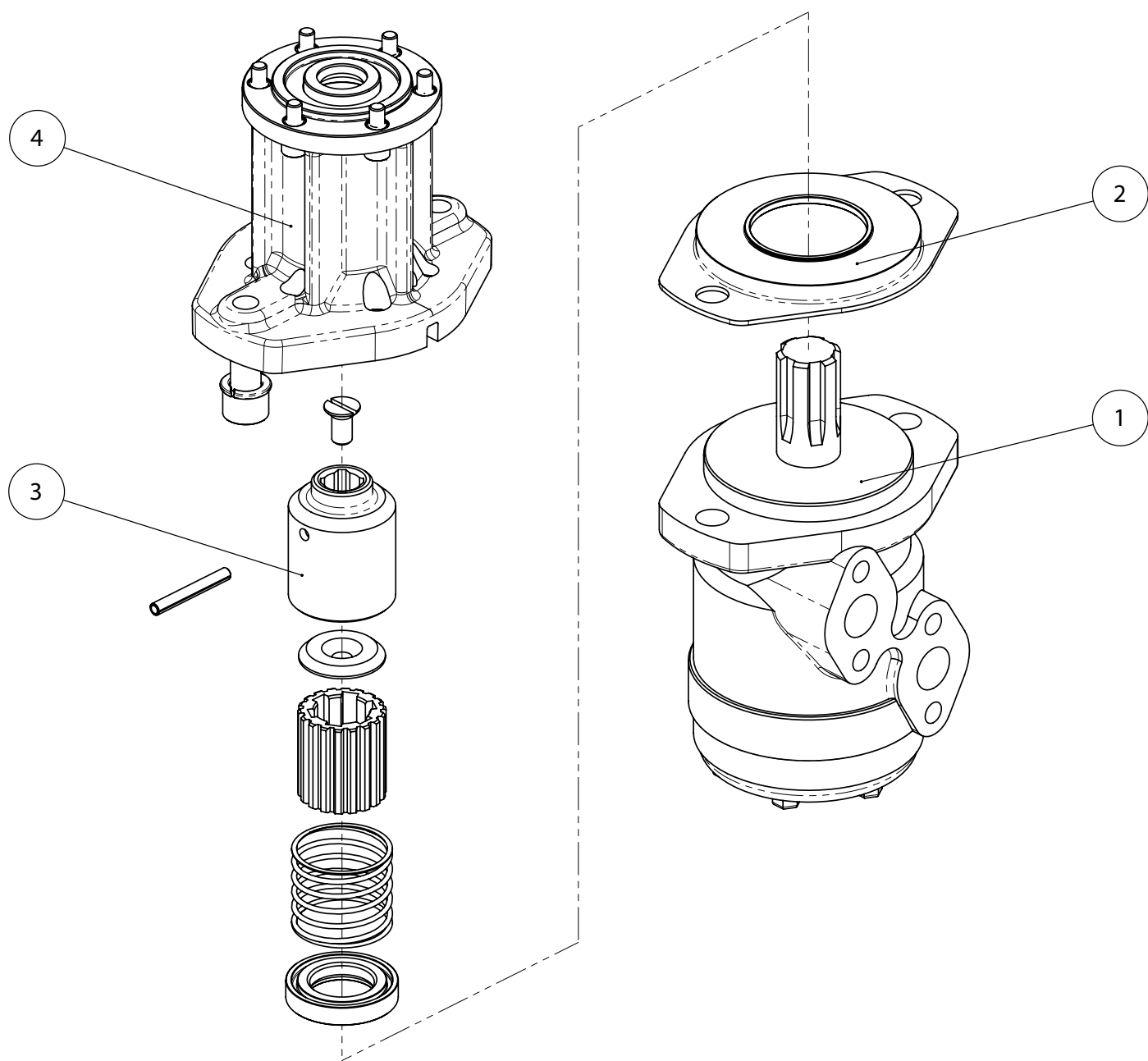

Pos.	Q.ty	Code	Description
1	1	G45942000Y	Hydraulic motor "OMR50 151-0420 alb.scan. 1"
2	1	S 41500 00 80	Hydraulic Motor Spacer
3	1	A 941932 00	KIT Clutch HY Motor (OMR50)
4	1	A 941491 00	KIT HY Motor Flange (OMR50)