

HARKEN®

MKIV JIB REEFING & FURLING

Unit 3, 4

Installation Manual – Intended for specialized personnel or expert users

4673 v2 04/22



Preassembly

Safety precautions/parts descriptions	2
Sizing check	3
Parts	4 - 5
Line/rigging parts check/tools	6
Dimensions/sailmaker's instructions	7
Toggle deductions/stay into foil options	8
Top foil length Unit 3/Unit 4	9 -10
Short top foil Unit 3/Unit 4	11 - 12
Confirm foil length	13

Assembly

Foils/connectors	14 - 20
Halyard swivel	20
Drum assembly	21
Rod rigging	22
Attach turnbuckle/toggle	23
Attach toggle/short length plate	24
Attach toggle/long length plate	25
Feeder/final	26

Commissioning—Unit 3/4

Turnbuckle on boat	27
Lead line to cockpit	28
Halyard wrap/prevent halyard wrap	29
Pendant/halyard: restrainer/ halyard tension	30

Commissioning—Unit 4

Tying soft attachment tack/head/halyard	31
---	----

Operation

Halyards/headstay tension	32
Raise sails/storm sails/reefing	33
Reef/secure sail	34
Race conversion	35

Maintenance

Clean/inspect	36
Replace line	36
Storage/remove furler	36

Troubleshoot	37
---------------------	----

Warranty	37
-----------------	----

Appendix	38 - 41
-----------------	---------

Please read these instructions carefully before installing, servicing, or operating the equipment.
This manual may be modified without notice. See: www.harken.com/manuals for updated versions.

PLEASE SAVE THESE INSTRUCTIONS

Safety Precautions/Parts Description

Introduction

This manual gives technical information on installation and service. The information is **destined exclusively** for specialized personnel or expert users. Installation, disassembling, and reassembling by personnel who are not experts may cause serious damage to property, injury to users, and injury to those in the vicinity of the product. If you do not understand an instruction, contact Harken.

The user must have appropriate training in order to use this product.

Harken accepts no responsibility for damage or harm caused by not observing the safety requirements and instructions in this manual. See Limited Warranty, General Warnings and Instructions at www.harken.com/manuals.

Purpose

Harken Jib Reefing and Furling systems are designed for rolling sails on sailboats to reduce sail size or to completely roll so wind has little effect on the sail. Use of this product for other than normal sailboat applications is not covered by the limited warranty.

Safety Precautions



WARNING! This symbol alerts you to potential hazards that may kill or hurt you and others if you don't follow instructions. The message will tell you how to reduce the chance of injury.



CAUTION! This symbol alerts you to potential hazards that may hurt you and others if you do not follow instructions. The message will tell you how to reduce the chance of injury.



WARNING! Strictly follow all instructions to avoid potential hazards that may kill or hurt you and others. See www.harken.com/manuals for General Warnings and Instructions.

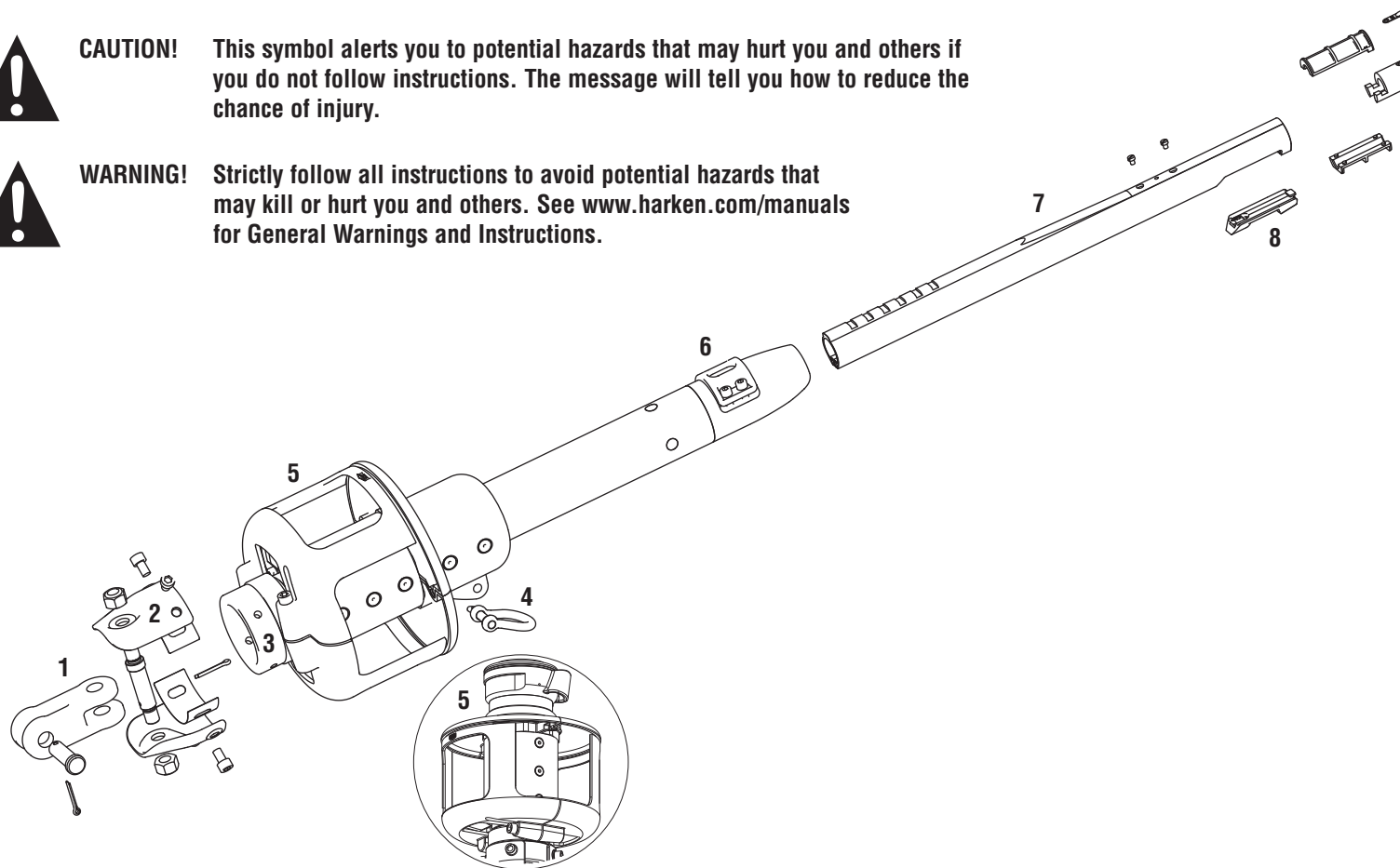

Unit 4 soft attachment

Parts Descriptions

- 1) Jaw/jaw toggle
- 2) Link plates
- 3) Hub extension
- 4) Shackles

- 5) Drum assembly
- 6) Foil clamp
- 7) 610 mm (2') bottom foil
- 8) Feeder

- 9) Connector bushing
- 10) Bottom connector
- 11) 2.13 m (7') foil
- 12) Connector screws

- 13) Connector wedge
- 14) Connector
- 15) Halyard swivel
- 16) Trim cap

- 17) Trim cap screws

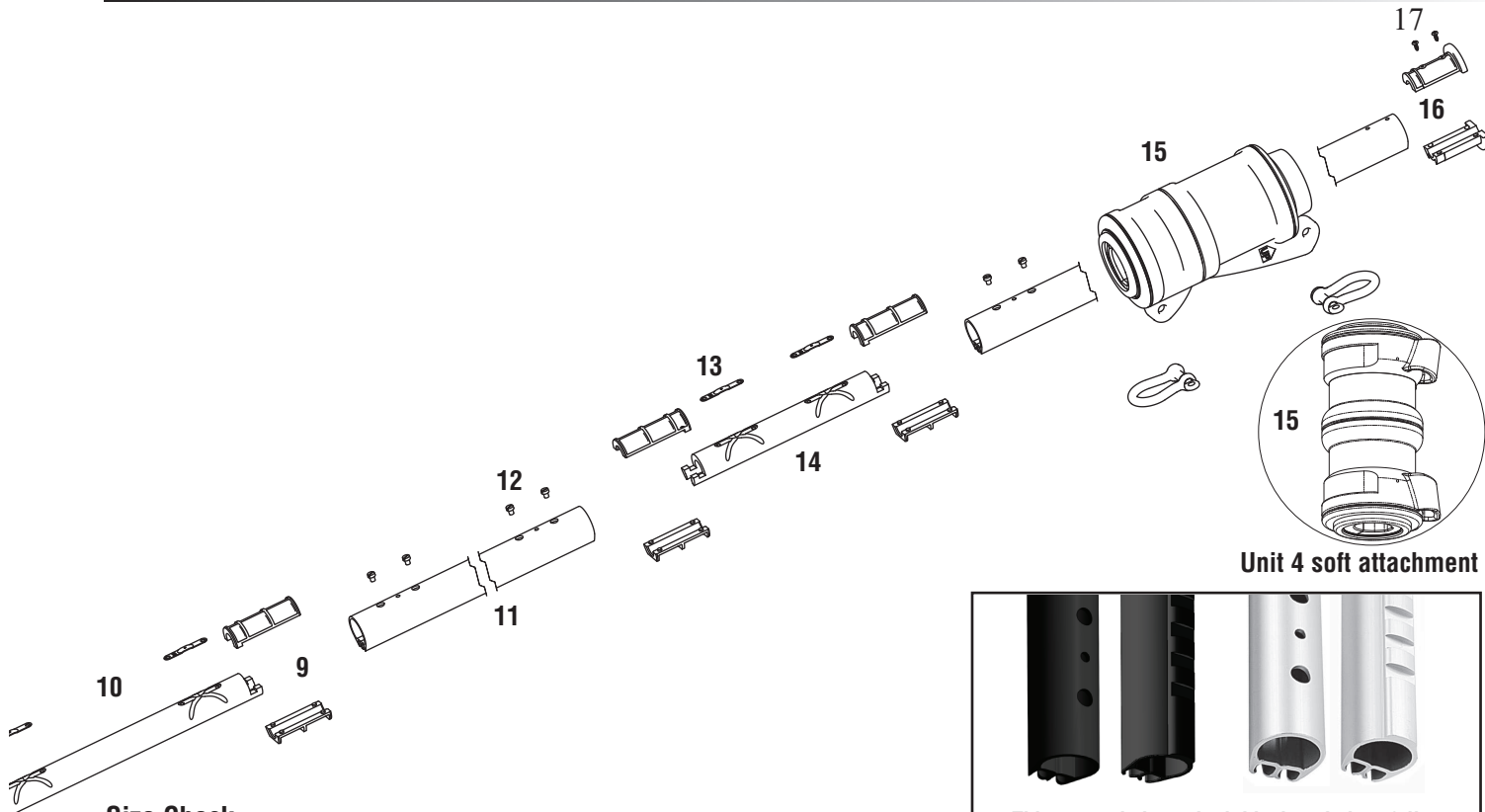

Size Check

1. Check headstay and clevis pin dimensions in chart below.

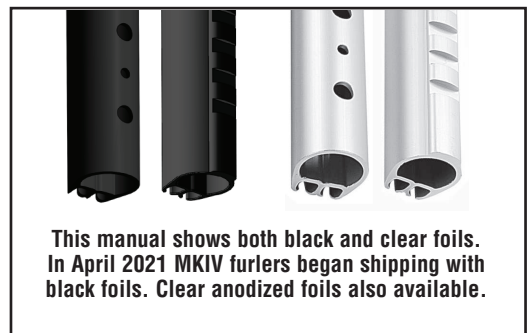

WARNING! Do not drill boat's chainplate or toggle. This may result in rig failure. Use the correct size toggle and clevis pin.

2. Harken does not recommend drilling boat's chainplate or toggle. Bushings may be required to fit boats with smaller clevis pin sizes.

3. Will drum fit on bow? See page 7. If necessary, use an additional toggle to slightly raise unit. To clear anchor use a Harken long link plate which can be cut to various lengths.

UNIT 3	Part no.	Description	Wire Ø	
	7413.10	MKIV Unit 3 Note: Black foils standard. Silver foils available.	$\frac{7}{16}''$, $\frac{1}{2}''$	11 mm, 12 mm
		Rod Ø		
		-22, -30	9.53 mm, 11.1 mm	
Toggle part no.		Description	Chainplate clevis Ø	
7413.20	3/4	Jaw/jaw toggle w/short link plate	$\frac{3}{4}''$	19.1 mm
7413.20	7/8	Jaw/jaw toggle w/short link plate	$\frac{7}{8}''$	22.2 mm
7313.21	3/4	Long link plate w/jaw/jaw toggle	$\frac{3}{4}''$	19.1 mm
7313.21	7/8	Long link plate w/jaw/jaw toggle	$\frac{7}{8}''$	22.2 mm
UNIT 4	Part no.	Description	Wire Ø	
	7414.10	MKIV Unit 4 Note: Black foils standard. Silver foils available.	$\frac{1}{2}''$, $\frac{9}{16}''$, $\frac{5}{8}''$	12 mm, 14 mm, 16 mm
		Rod Ø		
		-30, -40, -48	11.1 mm, 12.7 mm, 14.3 mm	
Toggle part no.		Description	Chainplate clevis pin Ø	
7414.20	$\frac{7}{8}''$	Jaw/jaw toggle w/short link plate	$\frac{7}{8}''$	22.2 mm
7414.20	1	Jaw/jaw toggle w/short link plate	1"	25.4 mm
7414.20	$1\frac{1}{8}''$	Jaw/jaw toggle w/short link plate	$1\frac{1}{8}''$	28.57 mm

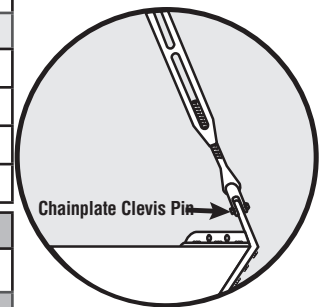

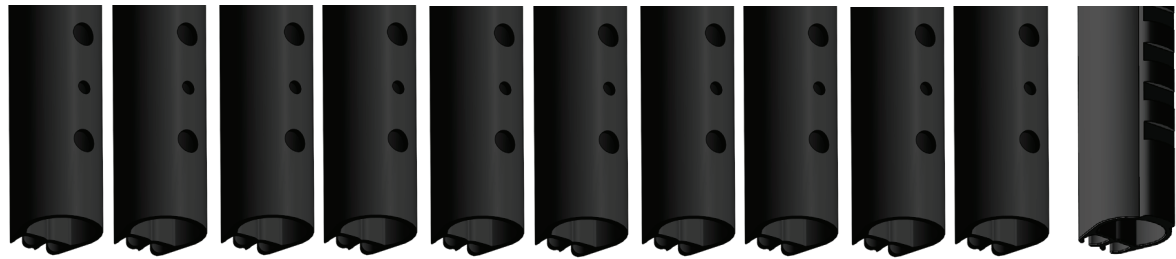

2.13 m (10 - 7') foils
Unit 3, 4

2' (610 mm)
Bottom Foil



Drum assembly
unit 3



Halyard swivel
unit 3



Silver foils available



Drum assembly
unit 4



Halyard swivel
unit 4

Main components - Unit 3

Description	Unit	Part No.	Qty
Drum assembly with clamp	3	HFG944	1
2.13 m (7') foil Standard		7413.30.BLACK	10
610 mm (2') bottom foil Standard		7413.33.BLACK	1
2.13 m (7') foil (Special)		7413.30.CLEAR	10
610 mm (2') bottom foil (Special)		7413.33.CLEAR	1
Halyard swivel		H-39392	1

Main components - Unit 4

Description	Unit	Part No.	Qty
Drum Assembly	4	HFG945	1
2.13 m (7') foil - Standard		7414.30.BLACK	10
610 mm (2') bottom foil - Standard		7414.33.BLACK	1
2.13 m (7') foil (Special)		7414.30.BLACK	10
610 mm (2') bottom foil - (Special)		7414.33.BLACK	1
Halyard swivel		H-45788	1

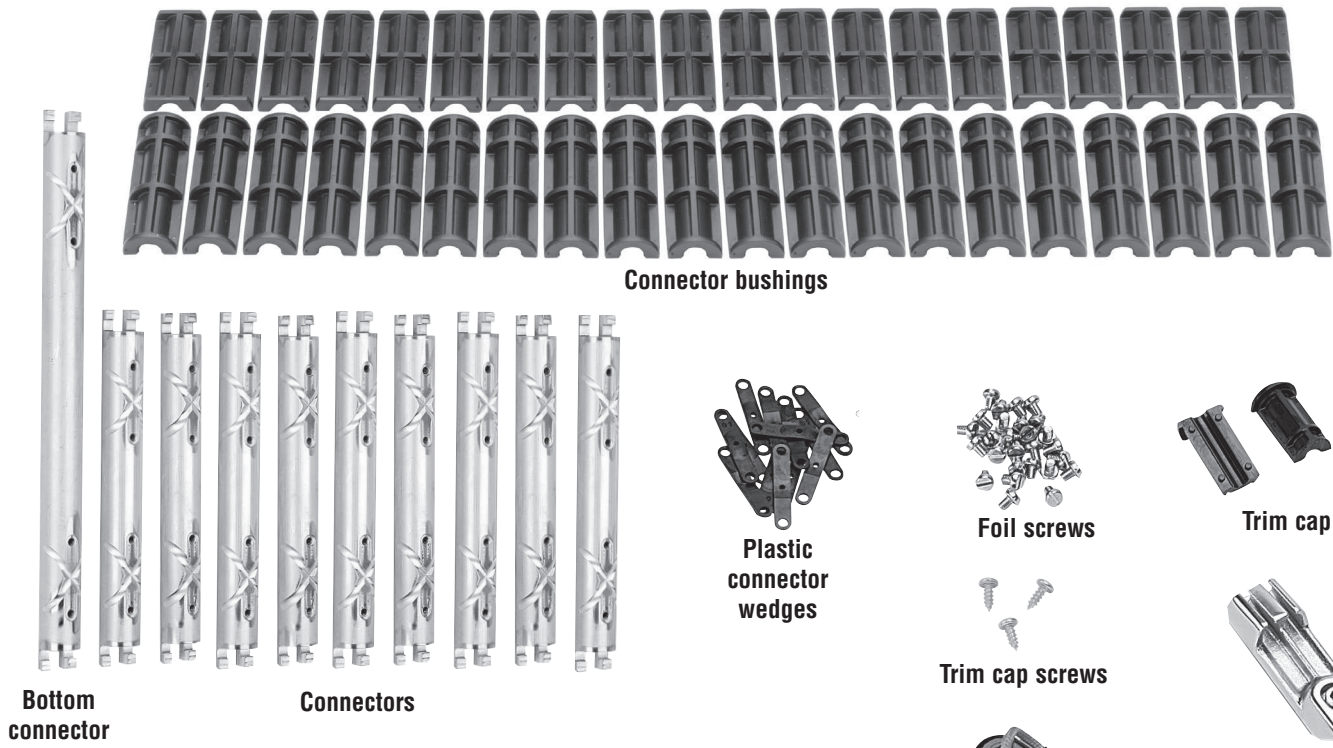

Other Components

Description	Unit	Part No.	Qty	Size
Connector	3	7413.31F	9	248 mm (9.75")
Bottom connector		7413.32F	1	356 mm (14")
Connector bushing set		HFG297 (20 EA H-42073/H-42074)	1	—
Plastic connector wedge set		HFG324 (22 EA H-39487)	1	—
Foil screw set		HFG349 (46 EA HFS1106)	1	—
Trim cap set		HFG682	1	—
Trim cap screw set		HFG672 (3 EA HFS1127)	1	—
Prefeeder		947	1	—
Feeder with screw and tab		H-39756	1	—
10 mm bow shackle		2124	3	10 mm
Blue Loctite® adhesive (for toggle link plates)		833	1	—
Red Loctite® adhesive (for screws)		HFG739	2	—
Injector, 1 oz. 5200 adhesive		HFG725	1	1 oz.

Connector	4	7414.31F	9	272 mm (10.7")
Bottom connector		7414.32F	1	386 mm (15.2")
Connector bushing set		HFG946 (H-45542/H-45543)	1	—
Plastic connector wedge set		HFG947 (24 EA H-45509)	1	—
Foil screw set		HFG948 (48 EA HFS1176)	1	—
Trim cap set		HFG949 (H-45550/H-45551)	1	—
Trim cap screw set		HFG672 (3 EA HFS1127)	1	—
Prefeeder		947	1	—
Feeder with screw and tab		H-45482	1	—
Blue Loctite® adhesive (for toggle link plates)		833	1	—
Red Loctite® adhesive (for screws)		HFG739	2	—
Injector, 1 oz. 5200 adhesive		HFG725	1	1 oz.



Loctite is a registered trademark of Henkel AG & Company KGaA.

Tools

Description	Unit	Qty
3, 4, 6, 10 mm hex keys	3	1 each
5, 6 mm hex keys	4	1 each

Preassembly

Line/Rigging Parts Check/Tools

Line Diameter/Length

Furling line is not included with furling unit. Purchase 12 mm (7/16") low - stretch polyester double - braid line. Line length should be equal to the length of the boat, plus the length of the foot of the largest genoa, plus 2 m (6').

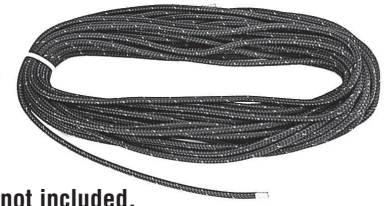

Line not included.

Toggles

1. Harken toggle assembly required. Sold separately.
2. Mating turnbuckle components, with eye at lower end, must be purchased separately. See page 8.
3. Headstay might require cutting and shortening to fit Harken toggle. Some headstays may remain uncut by replacing lower stud of turnbuckle with stud/eye, eliminating extra toggle.
4. Rod rigging requires Harken rod adapter stud.



WARNING! A stay that is old or damaged can break suddenly, causing an accident. Headstay condition should be checked by a professional rigger before reusing.

All Units.
Harken toggle
(sold separately).



Jaw/jaw toggle w/
short link plate

Unit	Part No.
3	7413.20 3/4
	7413.20 7/8
4	7414.20 7/8
	7414.20 1
	7414.20 1 1/8

Rod Rigging.
Harken rod adapter
stud required
(sold separately).



Long link
plate w/toggle

Unit	Part No.
3	7313.21 3/4
	7313.21 7/8



Rod adapter stud

Unit	Part No.
3	7426 -22
	7427 -30
4	7428 -40
	7429 -48

Tools You Will Need



1. Long tape measure	6. Side cutters	11. Center punch
2. Short tape measure	7. Rat-tail file	12. Rigging or black tape
3. Power drill	8. Hex keys (provided)	13. Scissors
4. Drill bit – 4 mm (5/32")	9. Slotted/Phillips screwdrivers	14. Metal straight edge
5. Hacksaw	10. Needle-nose pliers	15. Hammer

Adhesive Alert

MKIV furlers are shipped with 3M 5200 adhesive. Use adhesives on dry connectors and foils. Use the special injection system described in the assembly section. Parts may immediately be exposed to rain. Cure is best at 70 F (22 C) with 50% humidity. Do not apply at temperatures below 40 F (5 C) and above 100 F (38 C).

Although adhesive has not cured, it will remain in place on foil joints whether they are left on the ground or raised up on boat. Foils can be raised immediately after assembly and sails are fitted.

Note: A small amount of adhesive may bulge out of injection ports. If possible let system sit for several days before sailing. If adhesive gets on sails, remove using acetone. For faster-curing adhesive, purchase 4200 Fast Cure.

Note: Damaged foils can be repaired. Use a hand-held propane torch to heat joints until foils can be pulled apart.

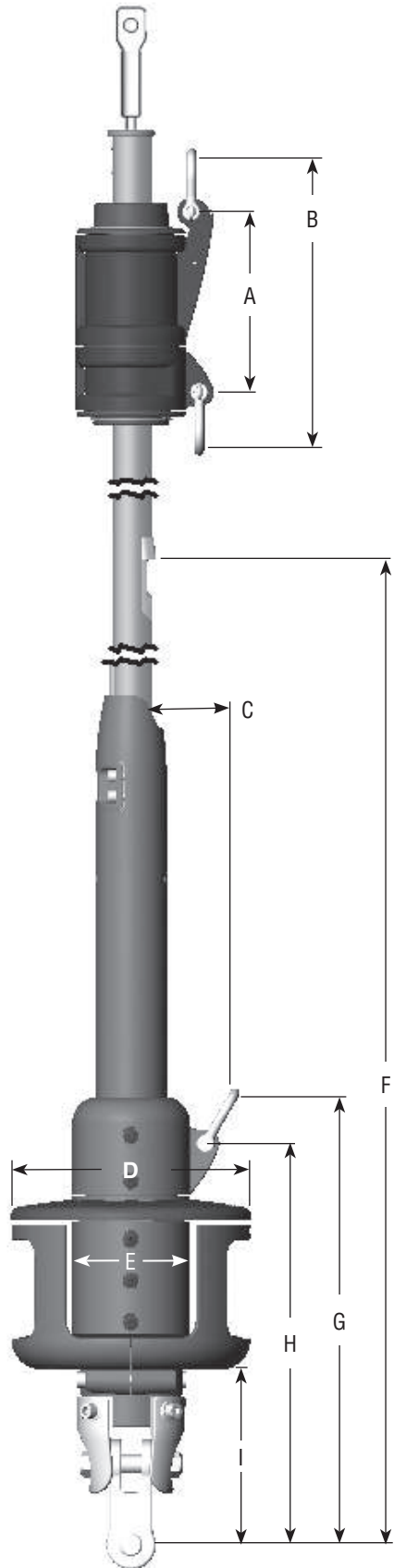

Luff Length

Note offsets above and below sail.

A shorter luff may be required if a halyard restrainer is necessary (page 31) or a toggle or long toggle assembly is used to raise the drum.

If luff of sail is not long enough to put halyard swivel near top of headstay foil, a pendant must be added. See page 29.

Tack Setback

Note setback for tack shackle and cut sail accordingly.

Luff Tape Size -6 (5 mm or 6/32")

J - Finished luff tape size: 5.5 mm (0.215")

K - Luff rope size: 4.8 mm (6/32", 3/16")

L - Max Ø in sail groove: 6.5 mm (0.26")

M - Gap in sail groove: 2.4 mm (0.096")

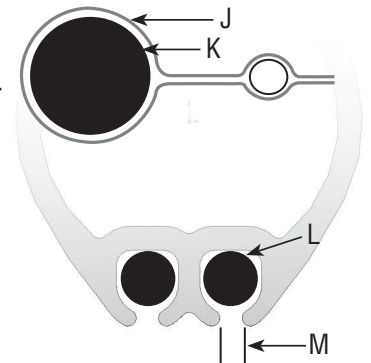

Luff Tape Length

Cut off top of luff tape so it is 450 to 600 mm (18" to 24") below head of sail. This allows head to lag behind rest of sail to help flatten it. It will also help the head to roll more smoothly.

Note feeder height and extend bottom of luff tape downward so it is below feeder. This will prevent luff tape from catching in feeder as sail is lowered.

Tack and Head Shackles (Unit 3 Only)

Make sure tack and head shackles fit sail rings. Minimum inside dimensions of standard head and tack shackles are:

(A) 48 mm (1 7/8")

(B) 21 mm (13/16")

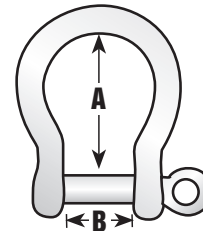

Sun Cover

Sun covers may be installed on either side of sail. Be sure to match other sails in the customer's inventory.

Unit 3 only - long link plate

Note: If a long link plate is used, add the following dimensions to feeder, shackle and drum height (based on whether plate is used full-length or shortened to one of five hole positions). Do not add to halyard swivel or top terminal dimensions.

19.1 mm (3/4") Clevis Pin	Add 497 mm to 271 mm (19 9/16" to 10 11/16")
22.2 mm (7/8") Clevis Pin	Add 505 mm to 279 mm (19 7/8" to 11")

Unit 4 only

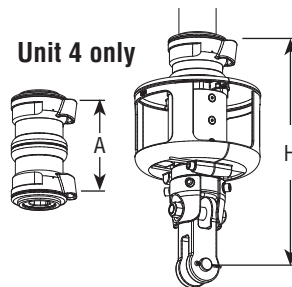

Unit	A	B	C	D	E	F		G		H		I	
						Max	Min	Max	Min	Max	Min	Max	Min
3*	7 5/16"	11 5/8"	3 3/8"	9 3/4"	4 3/4"	54 7/8"	54 5/16"	18 11/16"	18 1/16"	16 13/16"	16 1/2"	7 11/16"	7 1/8"
	186 mm	296 mm	86 mm	247 mm	121 mm	1394 mm	1380 mm	474 mm	460 mm	427 mm	413 mm	195 mm	180 mm
4	8 15/16"	—	—	11 1/16"	5 1/8"	53 3/4"	54 7/8"	—	—	20 1/4"	19 1/8"	8 7/8"	7 3/4"
	227 mm	—	—	280 mm	130 mm	1365 mm	1394 mm	—	—	515 mm	486 mm	225 mm	196 mm

*See note above regarding long link plates. **Drum assembly height increased 4" (100 mm) in 2020; older units will have lower feeder. MKIV Unit 3 and 4

Preassembly

Toggle Deductions/Stay Into Foil Options

Use dimensions of Harken toggle below to build stay to correct length.

Tip: Turnbuckles should be 1/2 to 2/3^{ds} open to allow shortening for new wire stretch and for fine-tuning mast rake.

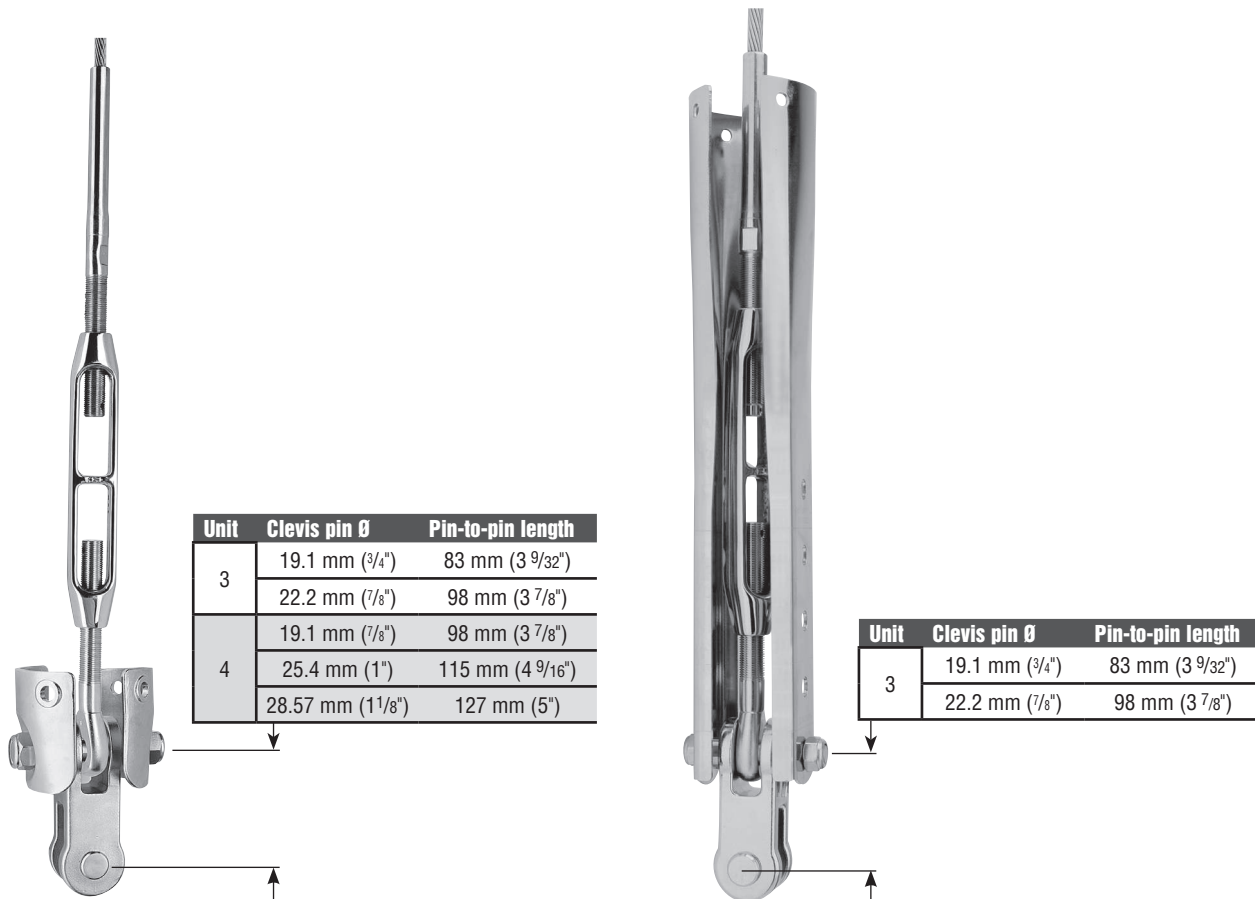

Options for Feeding Stay into Foils

1. Swage stud at end of wire.
2. Open end of wire and install Norseman or STA-LOK® stud after foil is assembled.
3. Rod adapter nosepiece for Harken rod adapter stud: Threaded nosepiece must have a positive lock as well as adhesive. Use Harken stud with cotter pins. See page 22.



WARNING! Using a threaded nosepiece with only adhesive at the upper rod eye terminal may result in headstay system failure. Make sure there is a mechanical lock.



Preassembly

Unit 3—Top Foil Length

Measure A and add to this chart and length chart below		
	Inches	mm
A		
B	1*	25*
E	24	610
F	26.25	667
G		
Total A+B+E+F+G		

Make sure upper measurement points of A and pin-to-pin are the same.

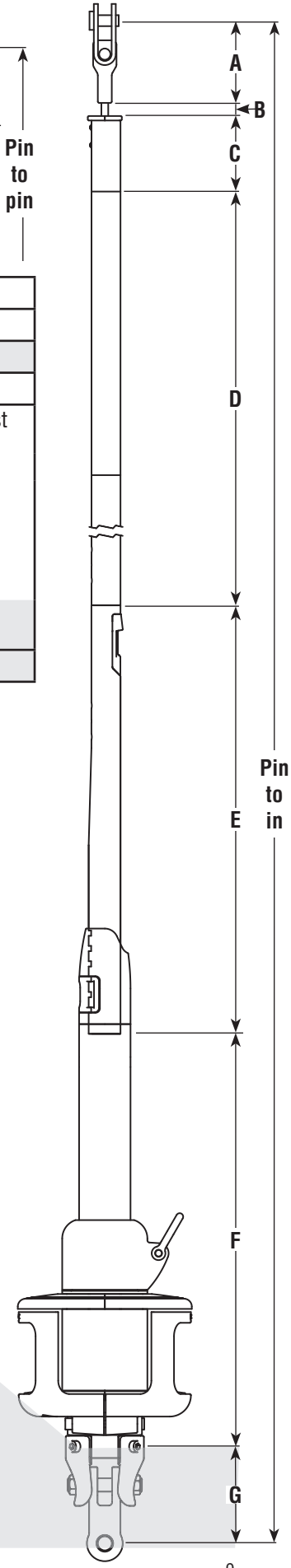
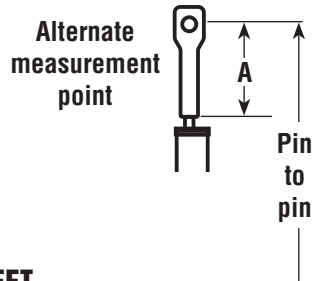

*Add 29 mm (1.12") if using a halyard deflector.



TOP FOIL LENGTH WORKSHEET

1	Pin-to-pin length	
2	Subtract ABEFG	-
3	Result (pin-to-pin - ABEFG)	
4	Subtract D	-
To find "D", pick number from chart below that is closest to, but not greater than total from step 3.		
Inches		mm
7 x 84 =	588	7 x 2133.6 = 14935.2
8 x 84 =	672	8 x 2133.6 = 17068.8
9 x 84 =	756	9 x 2133.6 = 19202.4
10 x 84 =	840	10 x 2133.6 = 21336
11 x 84 =	924	11 x 2133.6 = 23470
Example—If result from Step 3 is: 800 inches "D" = 756 inches; 20,000 mm "D" = 19202 mm		
5	Result (C) top foil length	

Length Check

After completing worksheet above fill in A, C, D, and G below. Add "A" through "G" to confirm total equals your pin-to-pin measurement.

Length chart		
Dimensions	Inches	mm
A Center of pin to bottom of terminal		
B Bottom of terminal to top of foil	1**	25*
C Top foil length		
D Number of foils _____ x 2133.6 mm (84")		
E Bottom foil	24"	610
F Bottom of foil to hub extension holes	26.25"	667
G Hub extension holes to clevis pin		
Pin-to-pin length		

*Add 29 mm (1.12") if using a halyard deflector.

G: Toggle distance from lower clevis pin to hub extension holes					
Toggle part no.	Type	Clevis pin		G distance	
7413.20 3/4	Jaw/jaw with short link plate	3/4"	19.1 mm	5.42"	138 mm
7313.20 7/8	Jaw/jaw with short link plate	7/8"	22.2 mm	6.00"	152 mm
7313.21 3/4	Long link plate w/toggle	3/4"	19.1 mm	22.00"	559 mm
7313.21 7/8	Long link plate w/toggle	7/8"	22.2 mm	22.63"	575 mm

Note: If long link plate is shortened, dimension must be changed or foil will be too short. Measure distance from hub extension holes down to where clevis pin attaches toggle to boat. Use this dimension in G above.

Measure A and add to this chart and length chart below		
	Inches	mm
A		
B	1"	25
E	24"	610
F	25.98"	660
G		
Total A+B+E+F+G		

Make sure upper measurement points of A and pin-to-pin measurements are the same.

Alternate measurement point

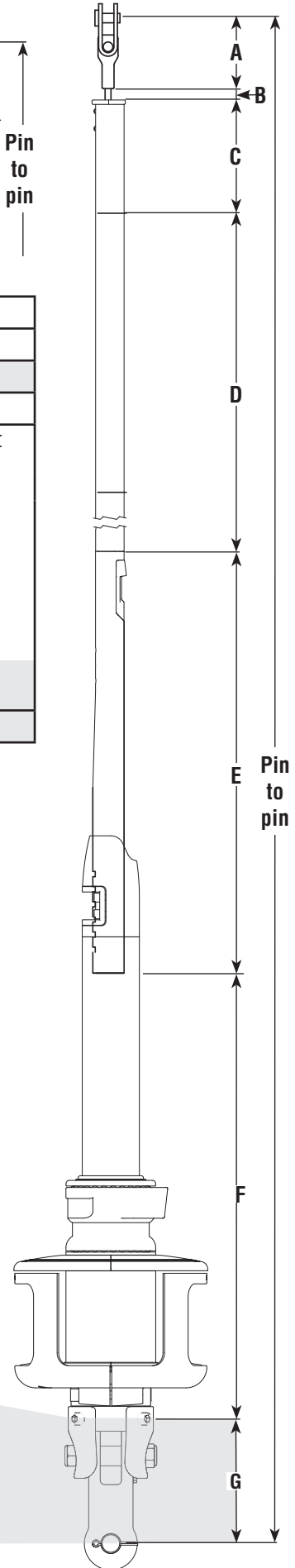
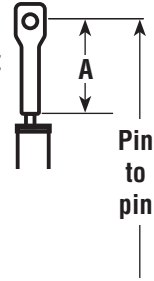

TOP FOIL LENGTH WORKSHEET

1	Pin-to-pin length	
2	Subtract ABEFG	-
3	Result (pin-to-pin - ABEFG)	
4	Subtract D	-
To find "D" pick number from chart below that is closest to, but not greater than total from step 3.		
	Inches	mm
	7 x 84 = 588	7 x 2133.6 = 14935.2
	8 x 84 = 672	8 x 2133.6 = 17068.8
	9 x 84 = 756	9 x 2133.6 = 19202.4
	10 x 84 = 840	10 x 2133.6 = 21336.0
	11 x 84 = 924	11 x 2133.6 = 23470.0
	12 x 84 = 1008	12 x 2133.6 = 25603.0
Example—If result from step 3 is: 800 inches "D" = 756 inches 20,000 mm "D" = 19202 mm		
5	Result (C) top foil length	



Length Check

After completing worksheet above fill in A, C, D, and G below. Add "A" through "G" to confirm total equals your pin-to-pin measurement.

Length Chart		
Dimensions	Inches	mm
A Center of pin to bottom of terminal		
B Bottom of terminal to top of foil	1"	25
C Top foil length		
D Number of foils _____ x 84" (2133.6 mm)		
E Bottom foil	24"	610
F Bottom of foil to hub extension holes	25.98"	660
G Hub extension holes to clevis pin		
Pin-to-pin length		

G Toggle Distance from Lower Clevis Pin to Hub Extension Holes					
Toggle part no.	Type	Clevis pin	G distance		
7414.20 7/8	Jaw/jaw with short link plate	7/8"	22.2 mm	5.95	151 mm
7414.20 1	Jaw/jaw with short link plate	1"	25.4 mm	6.64	169 mm
7414.20 1 1/8	Jaw/jaw with short link plate	1 1/8"	28.57 mm	7.01	180 mm

If top foil is shorter than 248 mm (9 3/4"), use one of the following techniques to ensure sufficient bearing surface for the foil in the area of the halyard swivel.

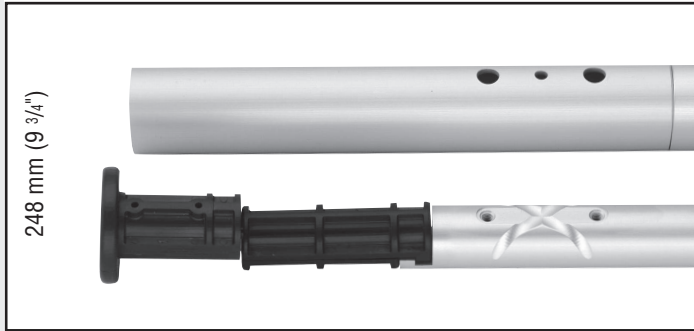

248 mm (9 3/4") No special treatment required.



244 – 181 mm (9 5/8" – 7 1/8") Do not use plastic bushing above top connector.

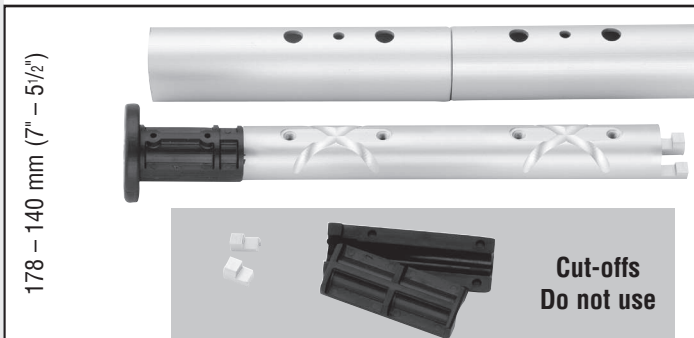

178 – 140 mm (7" – 5 1/2") Do not use plastic bushing above top connector. Shorten top of connector and, if necessary, shorten trim cap.

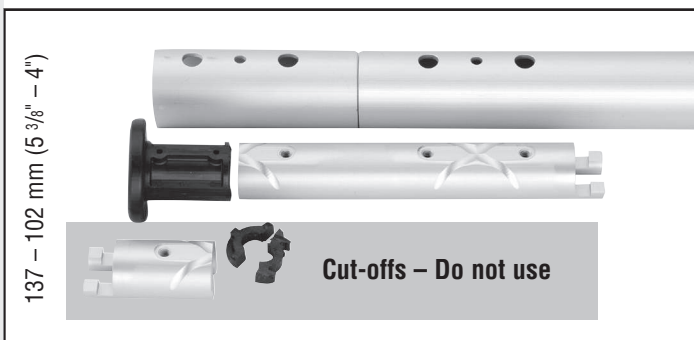

137 – 102 mm (5 3/8" – 4") Do not use plastic bushing above top connector. Cut connector at cross formed by glue dispersion channels. Use single foil screw in top foil only.



89 – 38 mm (3 1/2" – 1 1/2") Shorten top foil and adjoining full length foil so two (2) screws are used to assemble joint instead of four (4). Do not use plastic bushings above top connector.

Top foil length from worksheet	1. Initial top foil cut length	2. Cut through middle hole in top foil.* Resulting top foil length	3. Shorten full-length adjoining foil by cutting through middle hole.*	4. Shorten connector Length	5. Shorten trim cap
3 1/2" (89 mm)	6 9/16" (167 mm)	5" (127 mm)		4 7/8" (124 mm)	No
3" (76 mm)	6 1/16" (154 mm)	4 1/2" (114 mm)		4 7/8" (124 mm)	No
2 1/2" (64 mm)	6 9/16" (167 mm)	4" (102 mm)		4 7/8" (124 mm)	No
2" (51 mm)	5 1/16" (129 mm)	3 1/2" (89 mm)		4 3/8" (111 mm)	Yes
1 1/2" (38 mm)	4 9/16" (116 mm)	3" (76 mm)		3 3/4" (95 mm)	Yes

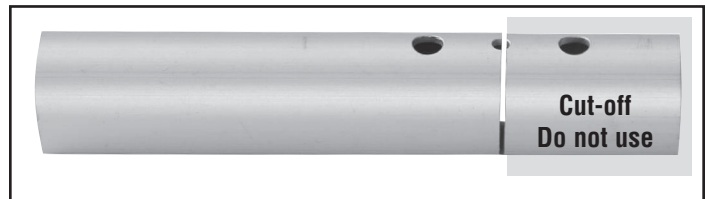

*To allow for saw cut, position blade so upper half of middle hole is preserved.

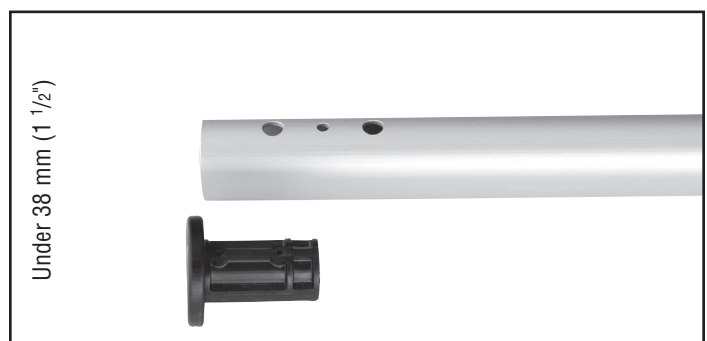

Under 38 mm (1 1/2") Eliminate top foil and run foil higher in drum assembly.

If top foil is shorter than 260 mm (10 1/4"), use one of the following special techniques to ensure sufficient bearing surface for the foil in the area of the halyard swivel.

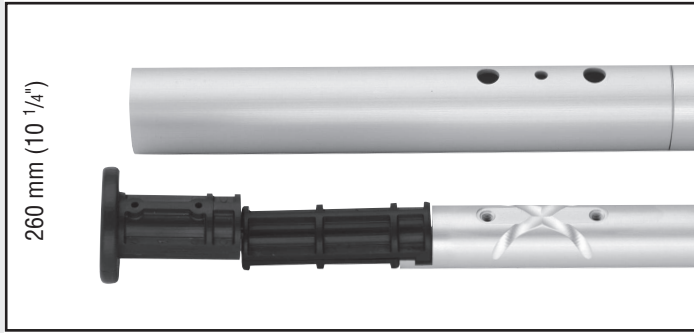

260 mm (10 1/4") No special treatment required.



258 - 192 mm (10 1/8" - 7 9/16") Do not use plastic bushing above top connector.

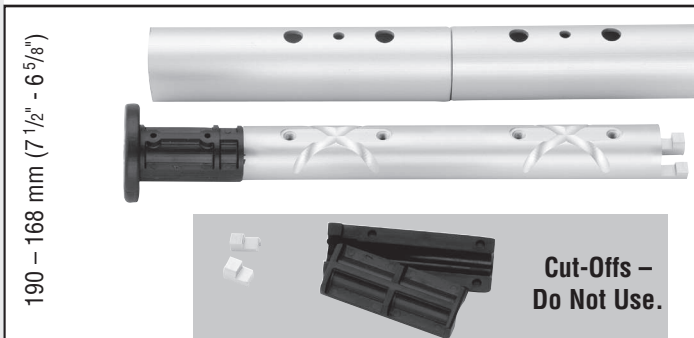

190 - 168 mm (7 1/2" - 6 5/8") Do not use plastic bushing above top connector. Shorten top of connector and if necessary shorten trim cap.

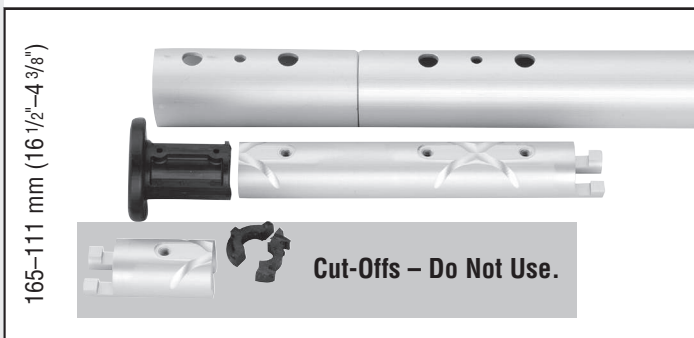

165 - 111 mm (6 1/2" - 4 3/8") Do not use plastic bushing above top connector. Cut connector right at cross formed by glue dispersion channels. Use single foil screw in top foil only.

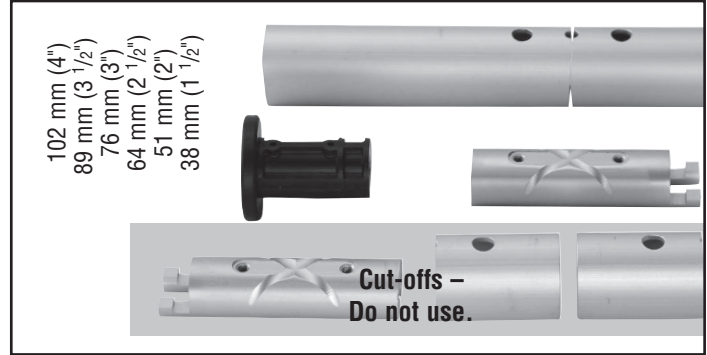

102 - 38 mm (4" - 1 1/2") Shorten top foil and adjoining full length foil so two screws are used to assemble joint instead of four. Do not use plastic bushings above top connector.

Top Foil Length from Worksheet	1. Initial top foil cut length	2. Cut through middle hole in top foil.* Resulting Top Foil Length	3. Shorten full length adjoining foil by cutting through middle hole.*	4. Shorten connector Length	5. Shorten trim cap
4" (102 mm)	9 3/32" (231 mm)	6 17/32" (166 mm)		5 11/32" (136 mm)	No
3 1/2" (89 mm)	8 19/32" (218 mm)	6 1/32" (153 mm)		5 11/32" (136 mm)	No
3" (76 mm)	8 3/32" (205 mm)	5 17/32" (140 mm)		5 11/32" (136 mm)	No
2 1/2" (64 mm)	7 19/32" (193 mm)	5 1/32" (128 mm)		5 11/32" (136 mm)	No
2" (51 mm)	7 3/32" (180 mm)	4 17/32" (115 mm)		5 5/32" (131 mm)	No
1 1/2" (51 mm)	6 9/16" (167 mm)	4 1/32" (103 mm)		4 1/2" (114 mm)	Yes

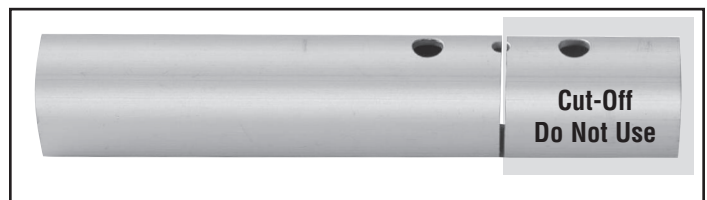

*To allow for saw cut, position blade so upper half of middle hole is preserved.

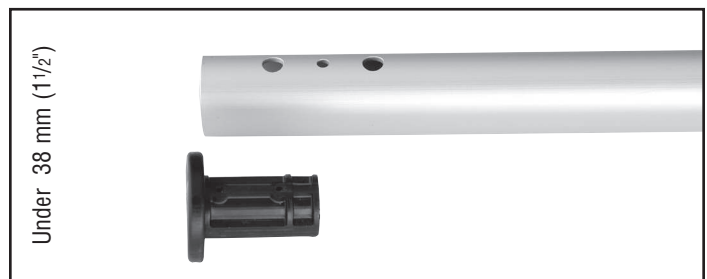

Under 38 mm (1 1/2") Eliminate top foil and run foil higher in drum assembly.

Preassembly

Confirm Foil Length

Confirm foil length by laying foils alongside stay with turnbuckle components.

Pull stay out so it is straight. Attach Harken toggle to bottom of stay. Make sure toggle straps are straight. Adjust turnbuckle so that length of stay with Harken toggle will fit boat. Turnbuckle should be one-half to two-thirds open to allow for rig adjustment.

Line up drum assembly so holes below drum line up with holes in Harken toggle. Make sure toggle is tensioned when measuring.

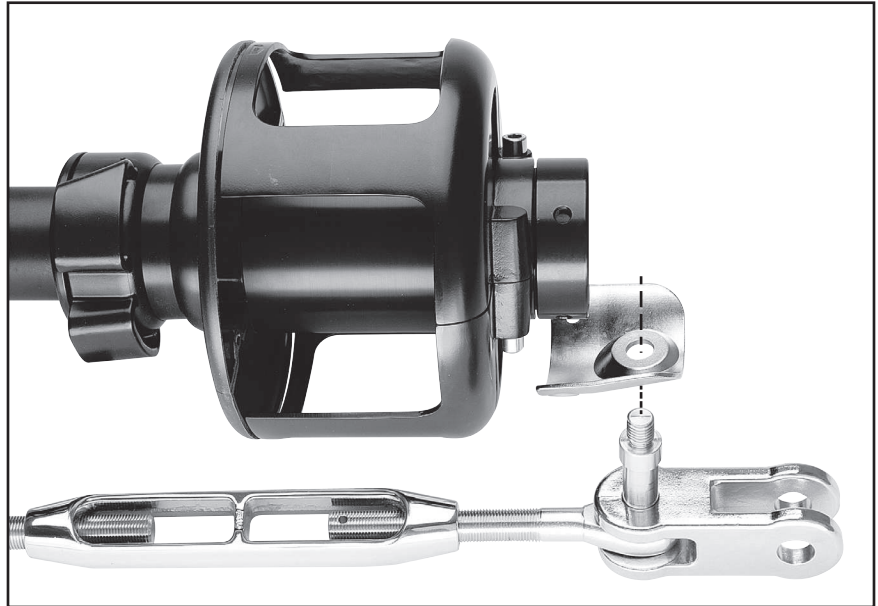

Line up bottom foil so foil clamp is centered or just below center of notches in bottom foil.

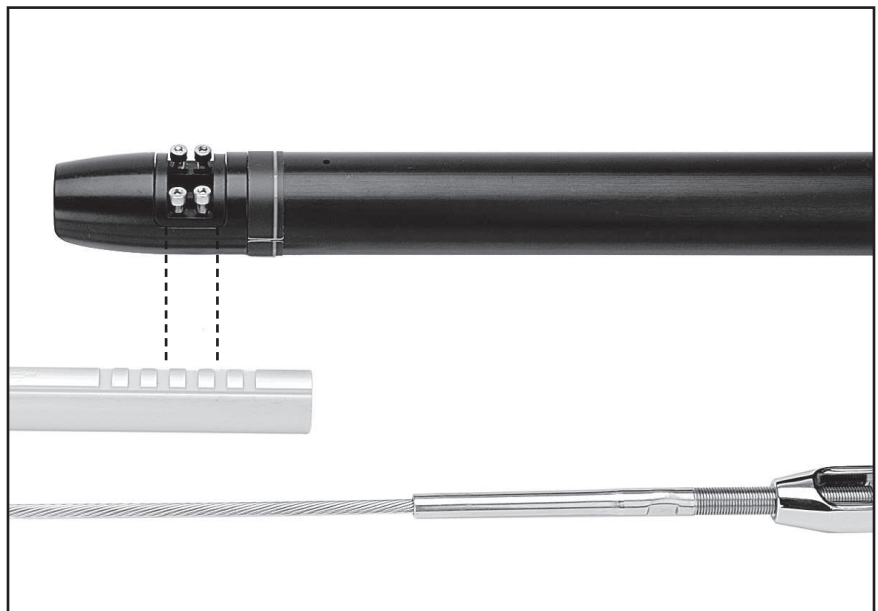

Note: Position top foil so that including top cap, the foil will ride 25 mm (1") below terminal. If wire fitting at top of stay is swage, foil must ride just below shoulder of swage. Mark cut line on foil. Wrap tape around foil as a guide so cut is straight.

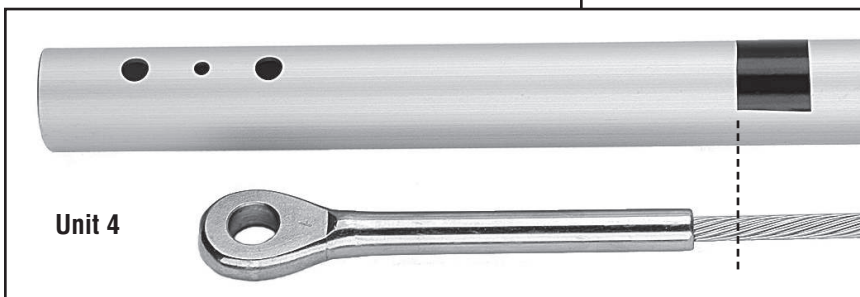
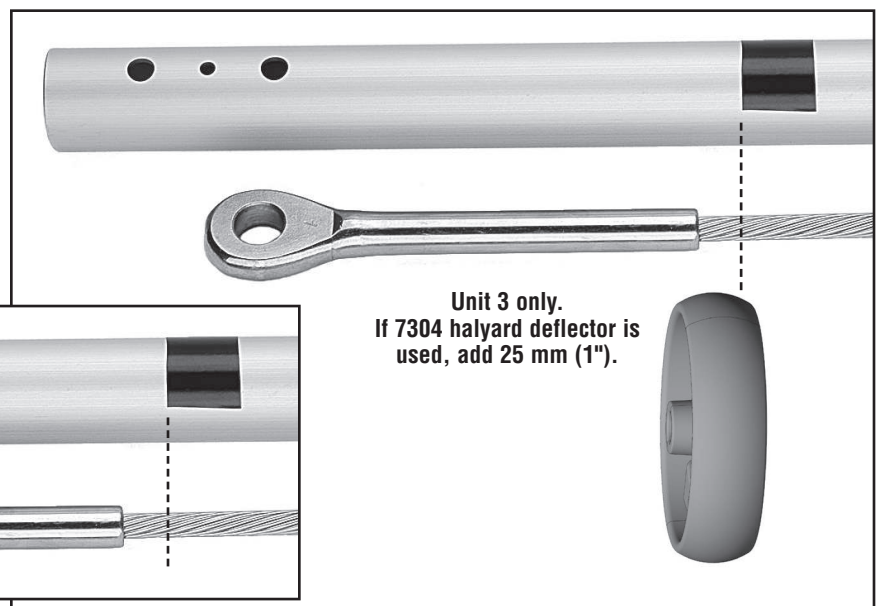

Cut foil to length using hacksaw.



Deburr inside edge using rat-tail file.

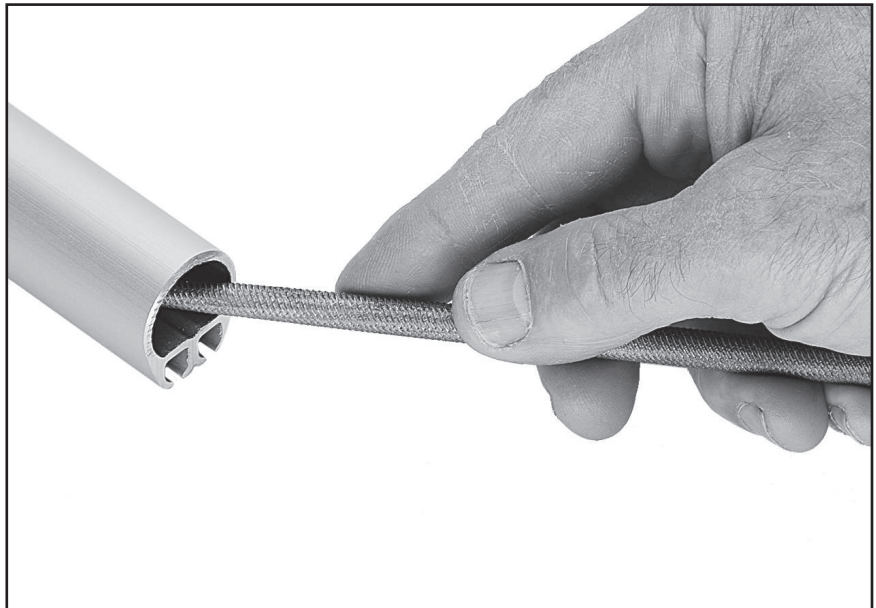

Prepare top foil for drilling.

Tip: Mark top foil to distinguish from cut-off piece.

Scribe line on top of foil to mark drill holes. Lay top foil alongside cut-off piece and use a flat metal object (i.e. metal ruler) to scribe top line of foil.

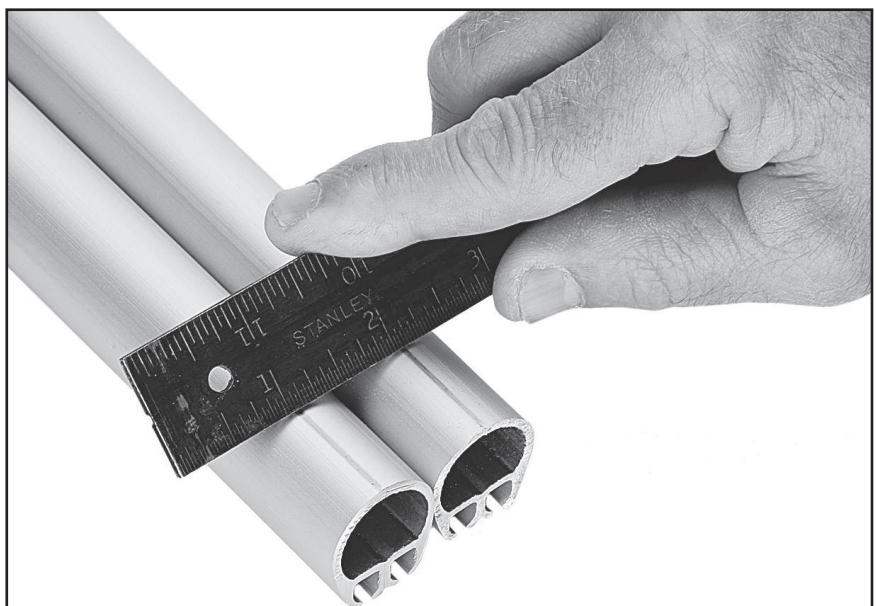

Cut out template at right. Line up template with top of foil and scribed line. Tape in place. Use center punch to mark holes.

Check center punch marks to confirm they are 10 mm ($3/8$ ") and 35 mm ($1 3/8$ ") from top of foil.

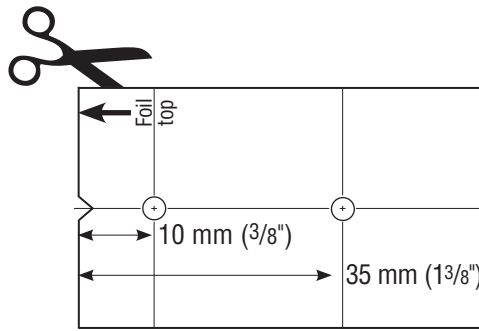

Unit 3, 4 template

Drill two (2) 4 mm ($5/32$ ") holes for trim cap.



Lay top foil in line with others. Slide stay into top foil and down line of foils, or slide each foil up stay.



Install trim cap. Place each side over wire.

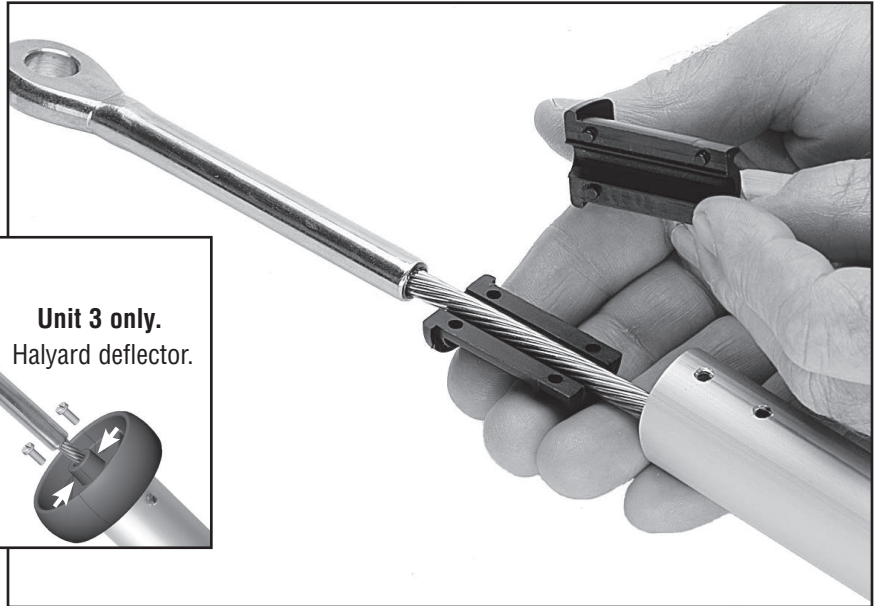
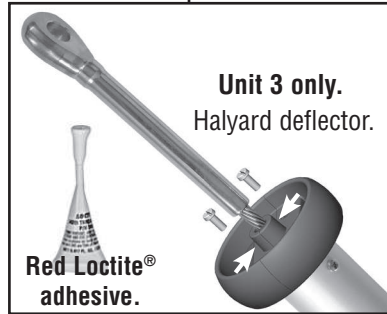

Push trim cap into foil to start; tap in using hammer.

Install trim cap screws.

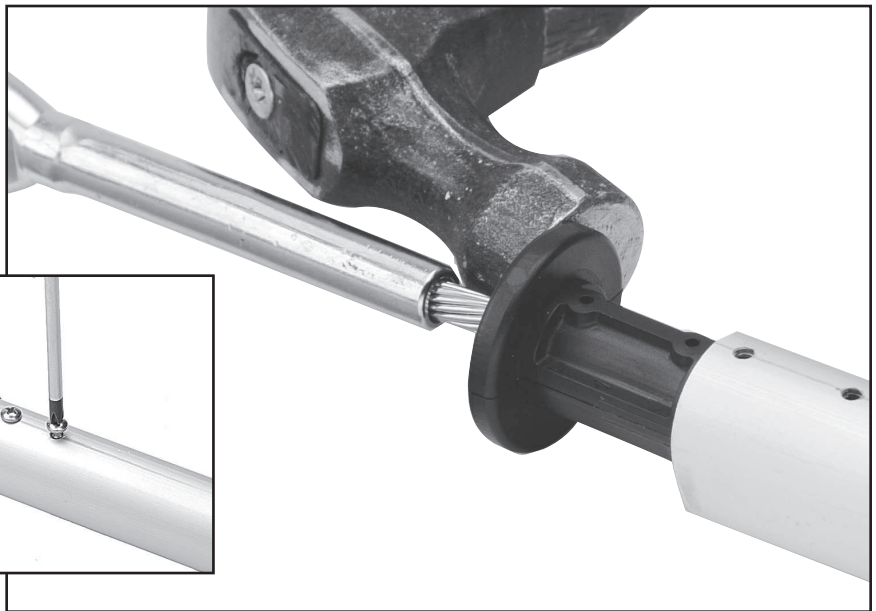

Place halves of plastic bushings on stay so hooked part of longer section faces out.

Tip: With foil screw holes up as shown below, place longer half of bushing with hook on upper half.

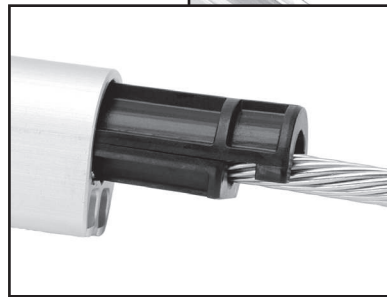

Assembly

Top Foil/Connectors

Slip connector on wire, mating hook of plastic bushing with connector.

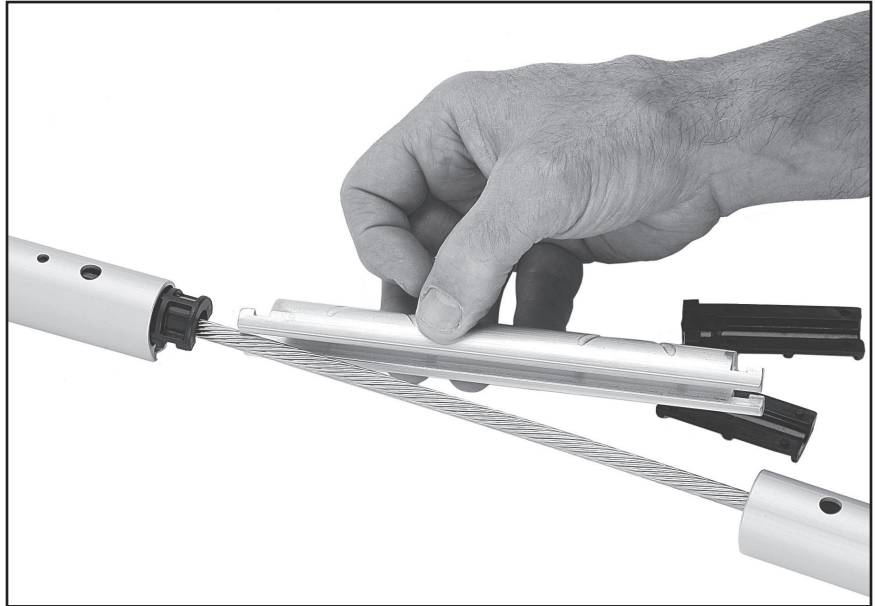

Put a drop of red Loctite® adhesive into screw holes.



Loctite is a registered trademark of Henkel AG & Company KGaA.

MKIV Unit 3 and 4

17

Hold plastic wedge in place with thumb as you insert into foil. Line foil holes with connector screw holes.



Loading Injector with Adhesive

Tip: In cooler weather, keep sealed adhesive in pocket to keep it warm. Use instructions below to fill injector less than half way; you will only use a small amount of adhesive. Refill if needed but do not keep open sealant for long periods. Use adhesive within three (3) hours.

Use cap of adhesive to break seal. Remove injector tip cap and plunger. Hold injector at an angle with applicator tip facing down. Squeeze adhesive into tube so lower half of injector is full as shown. Keep tip free of sealant to let air inside.

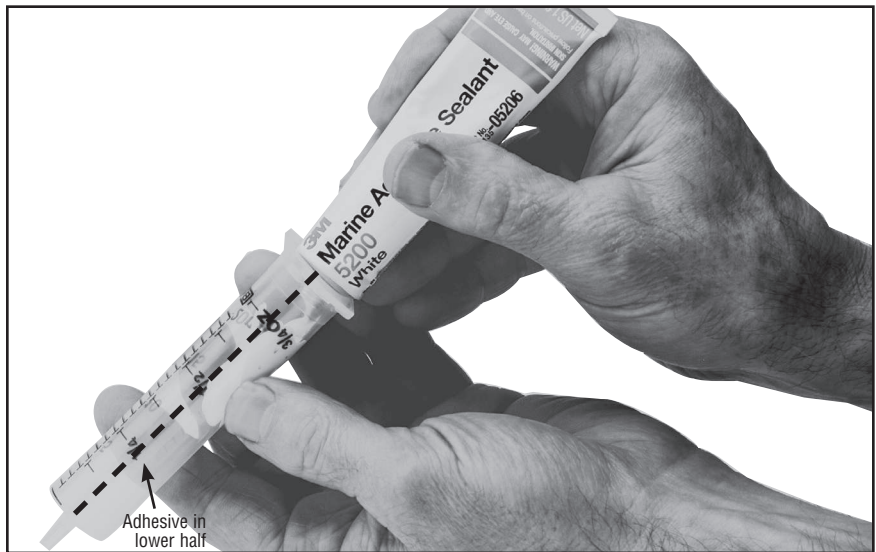

Start plunger into injector and immediately hold upright so plunger is down and applicator tip is up.

As sealant runs down toward plunger, an air pocket will form near tip. Push plunger to evacuate air. You are now ready to begin injecting adhesive.

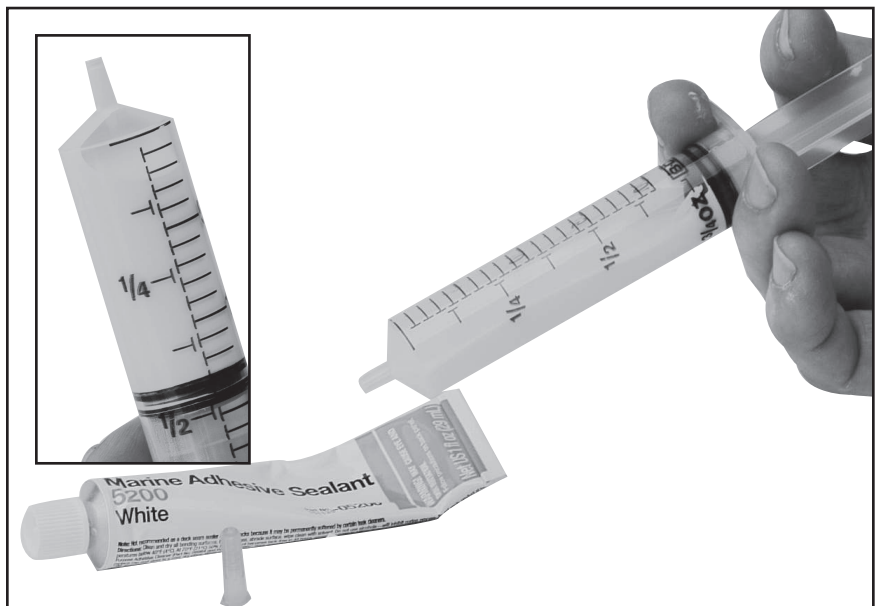

Inject only a small amount of adhesive into middle hole.

Unit	Adhesive
3	1 to 1 1/4 ml
4	1 1/4 to 1 1/2 ml

Tip: When you see a small amount of adhesive enter one screw hole, stop! You have applied enough adhesive.

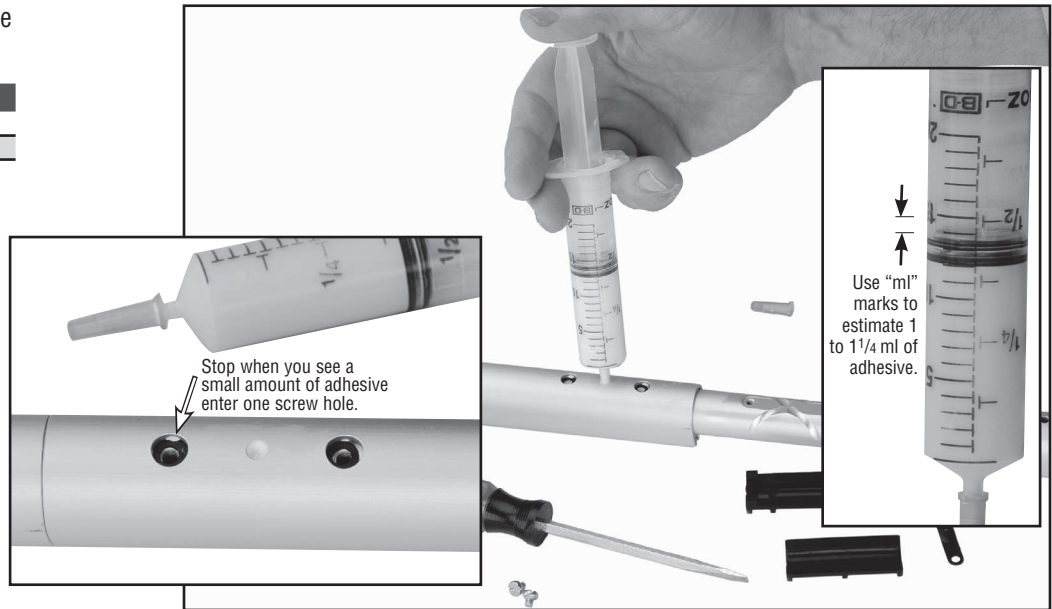

Tighten screws into connector holes. Make sure a drop of adhesive entered each screw hole. If not, apply to screw.

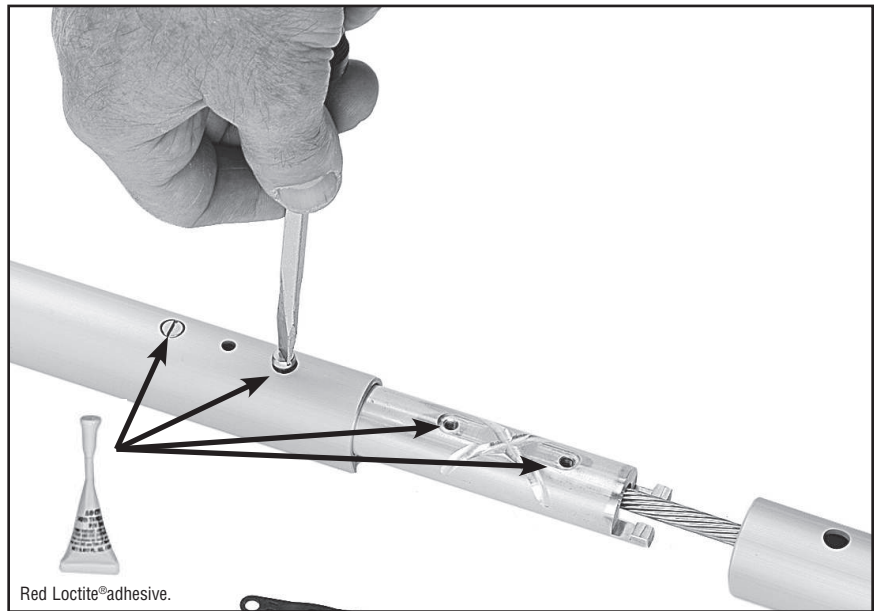

Use bushings, connector, wedge and adhesive in other screw hole and insert into other foil. Use 1–1 1/4 ml of adhesive.

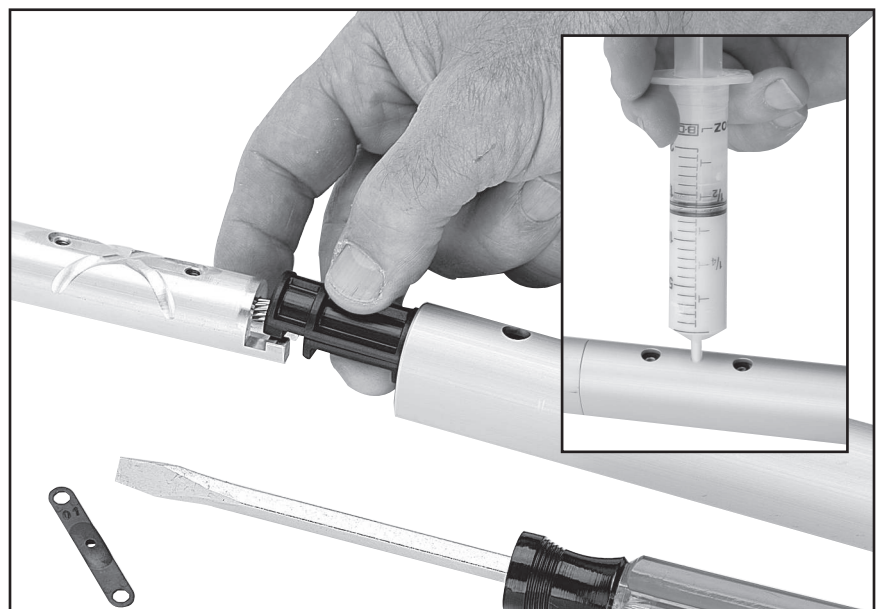

Assembly

Bottom Foil/Connectors/Halyard Swivel

Continue installing connectors and wedges. Make sure to use adhesive in screw holes.



**Red Loctite®
adhesive.**

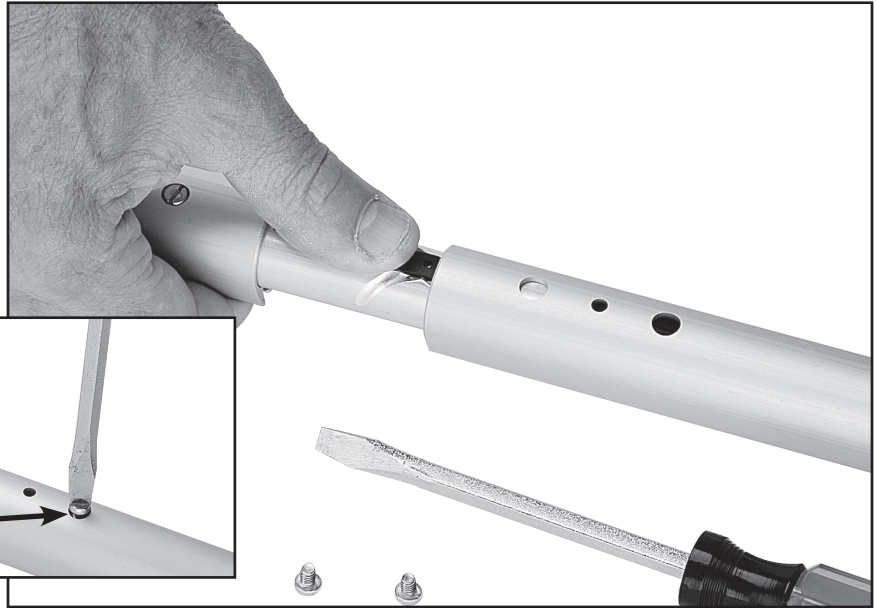

Continue assembly. Use 356 mm (14") bottom connector to assemble bottom foil.

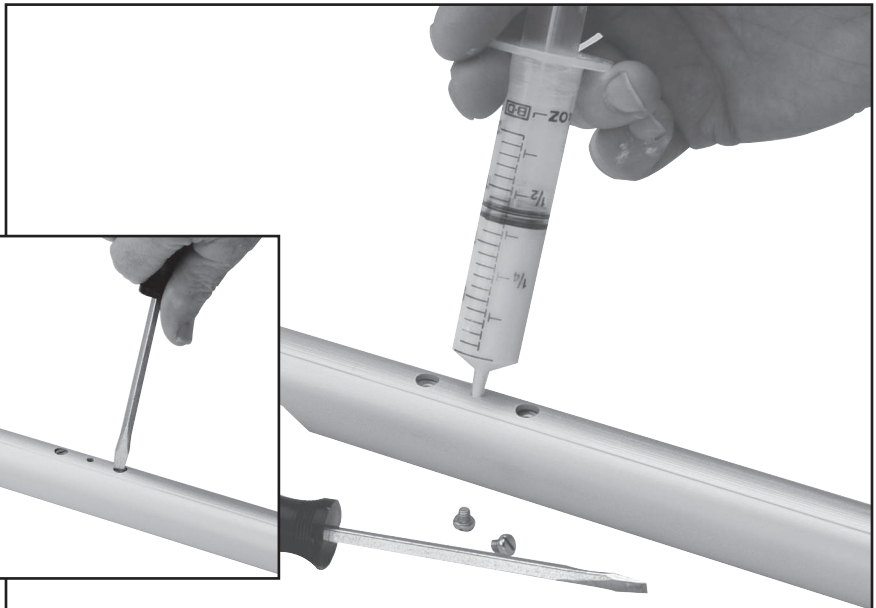
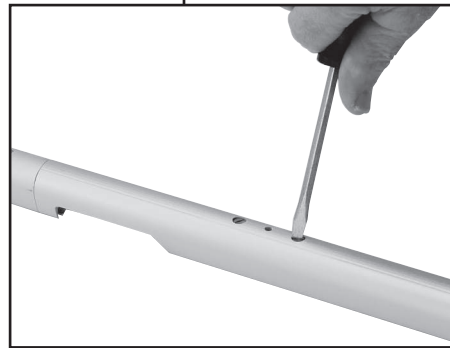

Slide halyard swivel onto foil above feeder window. Make sure taller "half" is up as shown.



Assembly

Drum Assembly

Loosen foil clamp screws at top of drum assembly.



Slide drum assembly onto foils.

Tip: Face clamp downward so it clears foil notches during installation.



G

Apply a few drops of red Loctite® adhesive to threads of nosepiece.

N

Screw main threaded stud portion onto bronze nosepiece until flats align with two cotter pin holes in terminal body.

Tip: Turn nosepiece completely into threaded stud portion. Flats will be close and may only require a small half turn to align with cotter pin holes.

I

G

G

R

I

D

Insert two cotter pins and spread. Clean excess Loctite from terminal body using special care to ensure that there is no red Loctite on threaded stud.

O

R

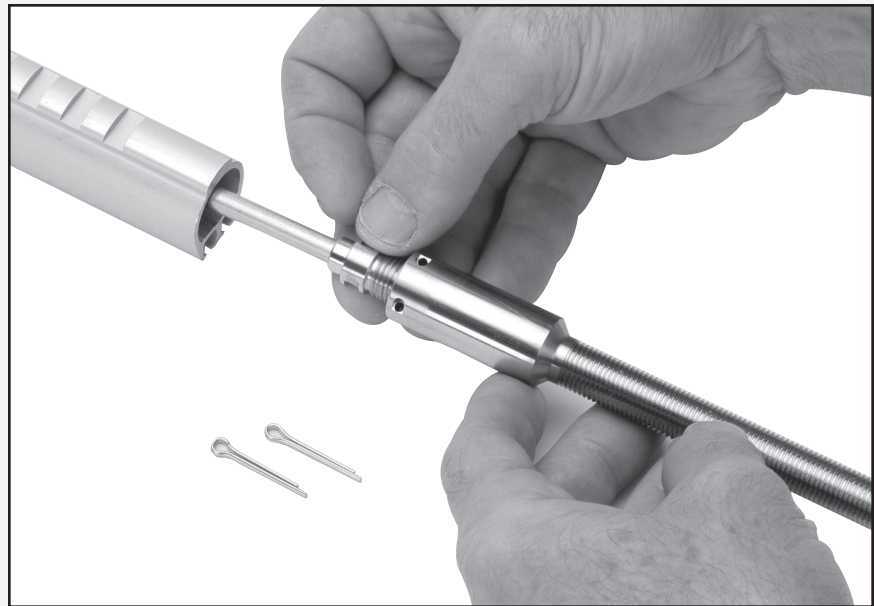
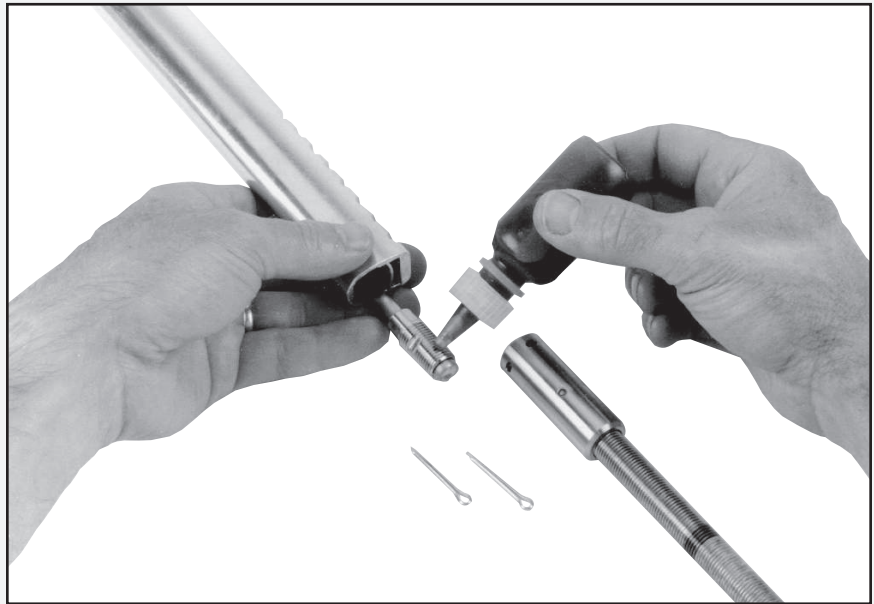

Assembly

Attach Turnbuckle/Toggle

Assemble turnbuckle.

Note: If using STA-LOK® or Norseman stud, you must use a washer above stud as shown below.

STA-LOK is a registered trademark of Barfield Engineering Company Ltd.

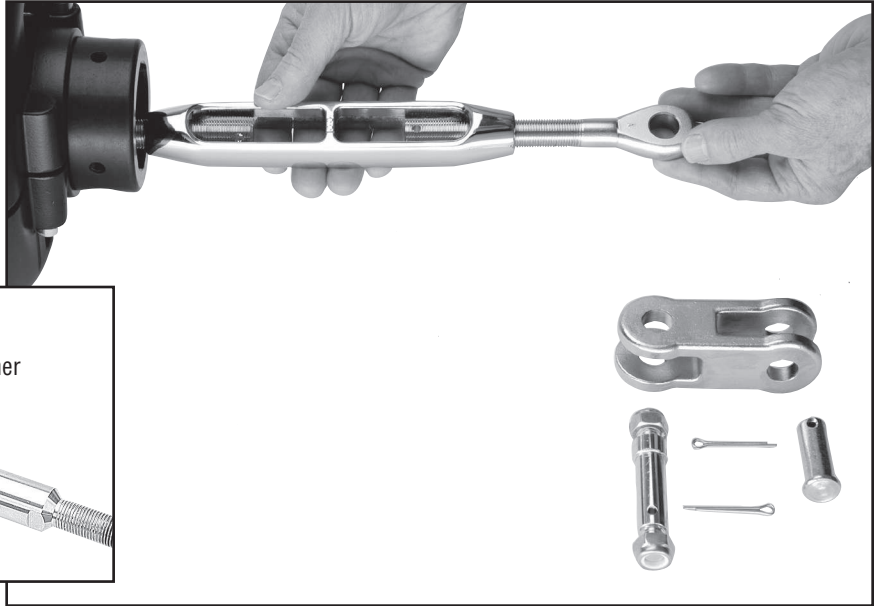
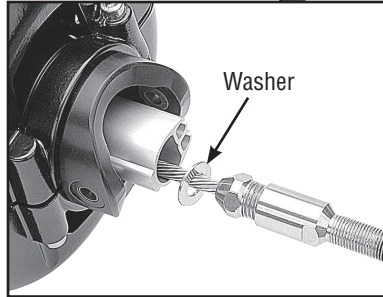

Connect eye to toggle jaw using special clevis pin.
Secure using cotter pin.

Make sure shallow jaw is up.

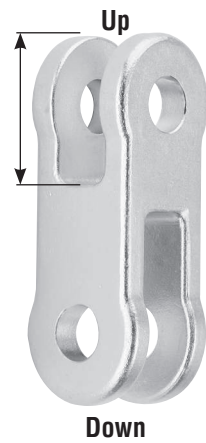

If stay length is set, use side cutters or
needle-nose pliers to bend cotter pin
to secure turnbuckle.



Assembly

Unit 3, 4—Attach Toggle/Short Link Plate

Apply isolator.

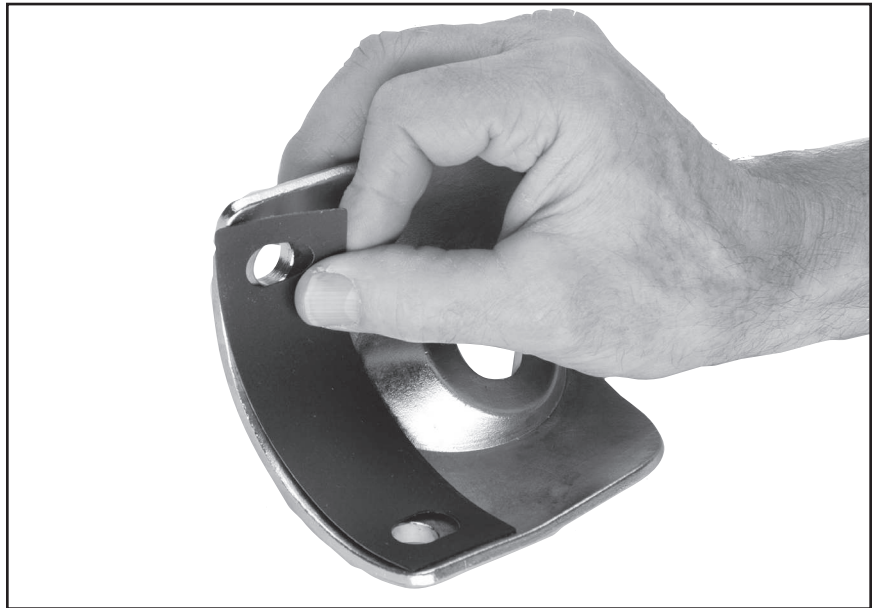

Recess turnbuckle into drum assembly, slip link plates over special clevis pin, and secure using fasteners. Use blue Loctite® adhesive on screws.

Loctite is a registered trademark of Henkel AG & Company KGaA.



Secure to toggle using lock nuts.

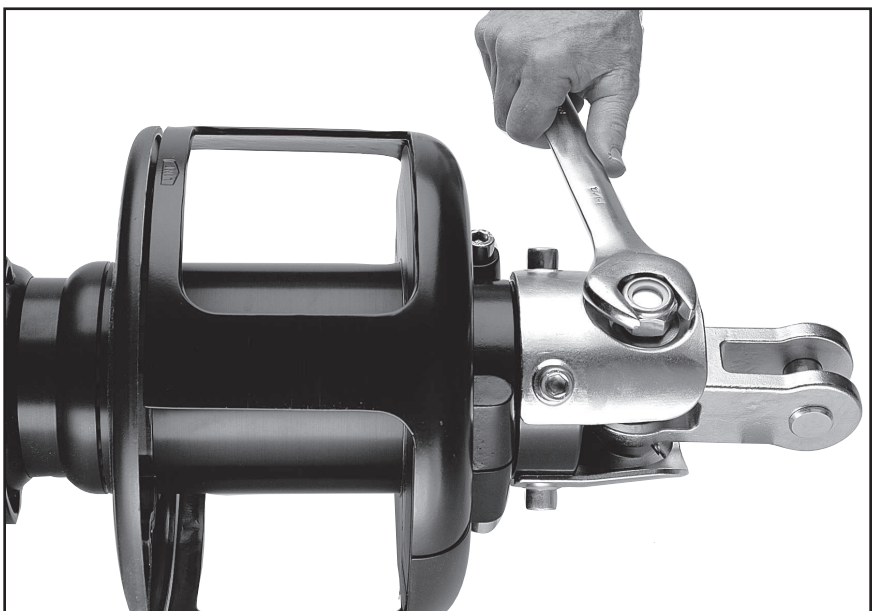

Determine height of link plates to provide anchor clearance and cut to length.

Cut at scribe mark. Deburr edges.



Apply isolator.



Fasten one long link plate to drum assembly using fasteners. Use blue Loctite® adhesive on screws.

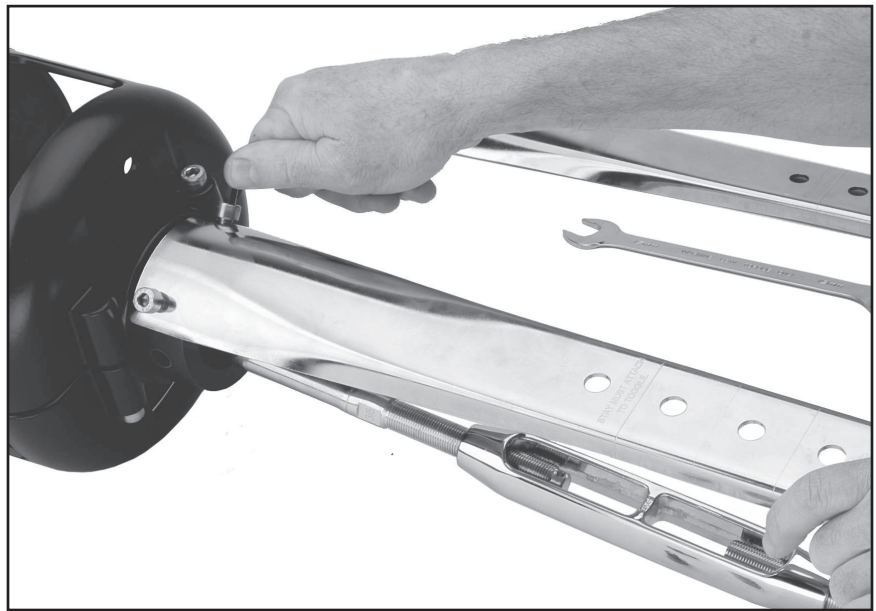

Fasten second long link plate to drum assembly and secure to toggle using locknuts.



WARNING! Stay must attach to toggle. Do not attach stay to crosspin at drum assembly because crosspin and plates can fatigue and break.

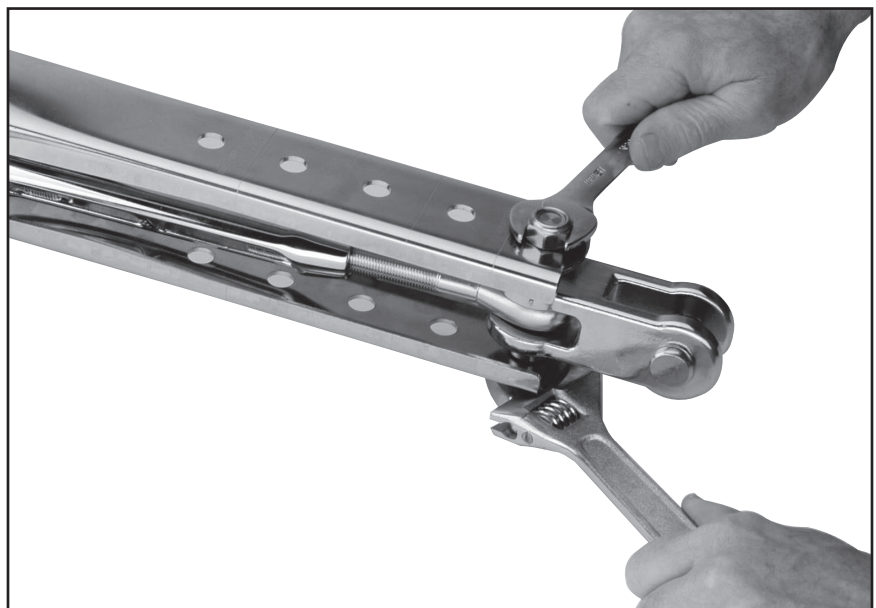

Check foil height at top; set and secure using hex key.



Slide halyard swivel above feeder. Place feeder in foil recess. Push screw down so tab catches under foil. Tighten screw.

Note: Screw will turn with some difficulty. It is plastic-coated to prevent loosening due to vibration.

IMPORTANT! When removing screw, loosen no more than one full turn. Slide screw up and remove feeder.

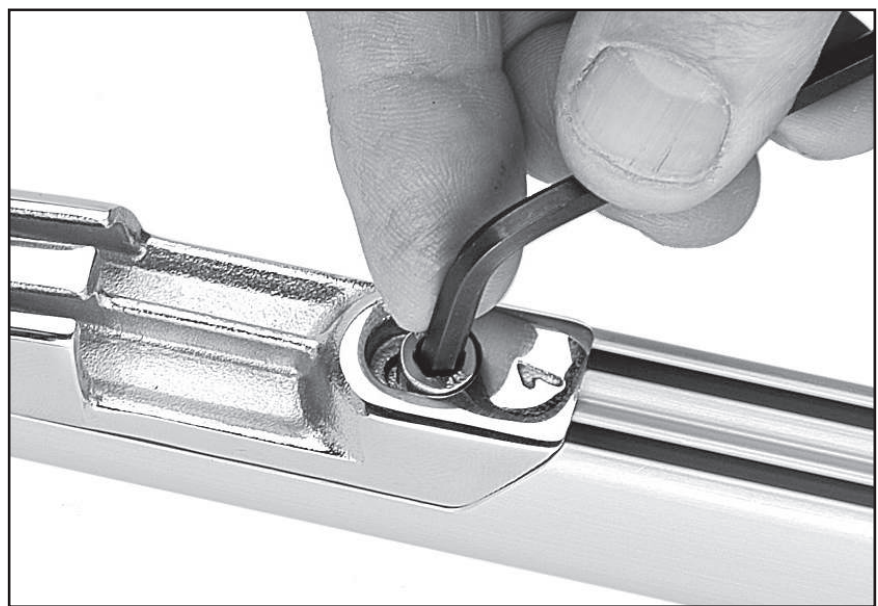
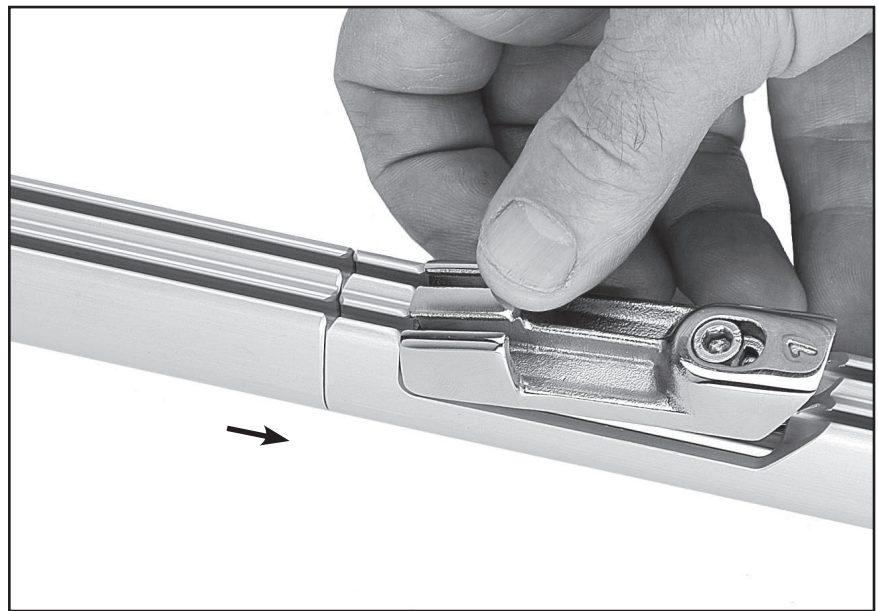

Commissioning—Unit 3, 4

Turnbuckle on Boat

Have extra cotter pins and locknuts on hand to replace used ones at base of unit and for turnbuckle.

Hold foils and loosen drum assembly screws until you can pull clamp out to lower foils.

Lower foils.

Remove link plates.

Raise drum assembly and use halyard to lift and hold it about 1.5 m (5'). Raise foils using second halyard and secure. **Allow room above for turnbuckle take up.**

 **WARNING! Make sure drum assembly and foils are securely lifted with a halyard before adjusting turnbuckle. Foils can drop suddenly, causing injury to hands.**

Adjust turnbuckle.

Replace used cotter pins and locknuts. Lower drum assembly and install clevis pin and new cotter pin.

Lift foils so top is 25 mm (1") below upper terminal.

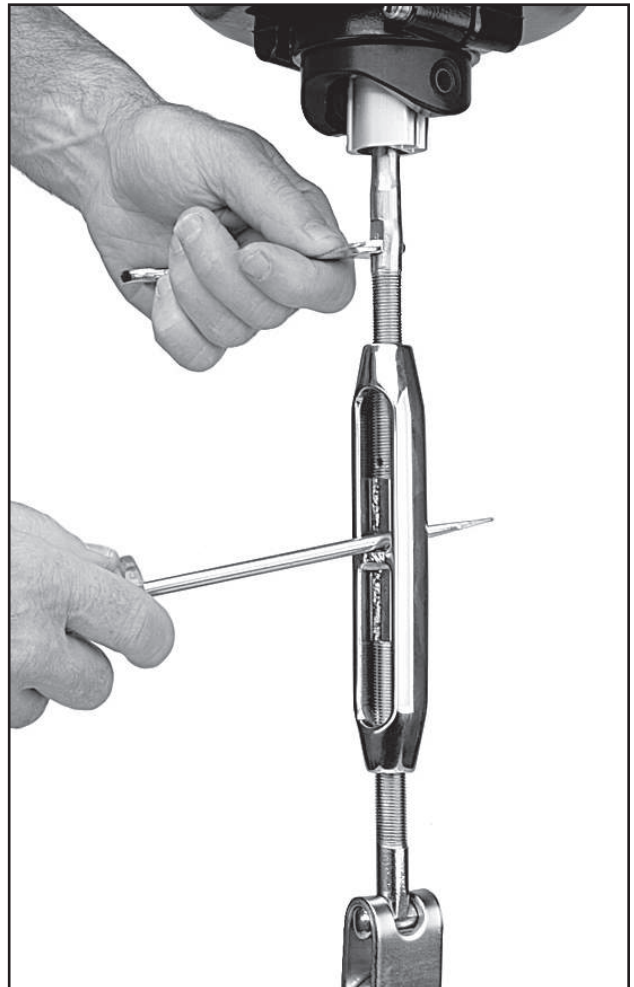

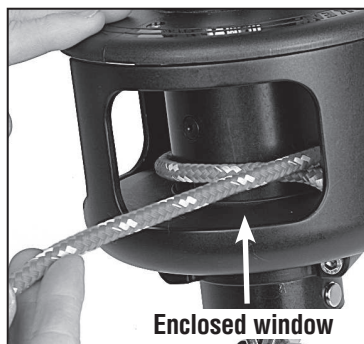

Run line through enclosed window in guard and into hole in bottom flange of spool. Tie a small overhand knot and pull it up under drum assembly.



WARNING! Lead line through enclosed window. If line is led through opening between two enclosed windows, it can ride above line guard and jam furler which can cause loss of control of boat.

Note location of sun cover. With no sail on unit, charge system by rotating furler to wrap line on drum. Leave a comfortable-length line tail in cockpit. Fine-tune line length on all points of sail after sail is hoisted and set.

Tip: Sun cover to starboard—turn clockwise to charge. Sun cover to port—turn counter clockwise. Tension line while charging.

Mount lead blocks

Furling line can be led down either side of boat. If boat is in slip, consider mounting opposite dock.

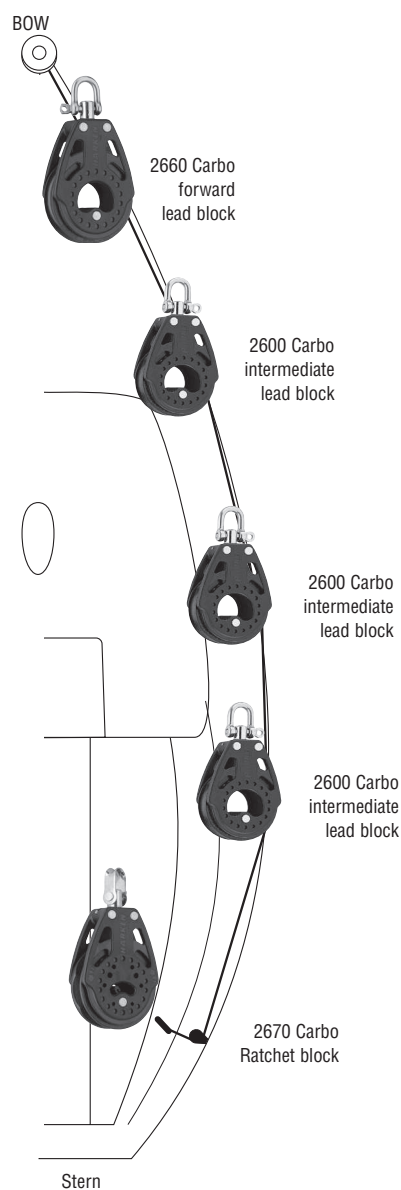

2660 Forward Lead Block

Position 2660 forward stanchion block so line enters drum at right angles to headstay and centers vertically in opening. Install so line is inside stanchion.

Correct block position is critical to even line spooling and ease of furling.

2600 57 mm Carbo Intermediate Lead Blocks

Install 2600 intermediate lead blocks so line is inside stanchions.

Number and placement of leads depends on boat length and number/configuration of stanchions.

2670 75 mm Carbo® Ratchet Block

Mount 2670 Carbo® Ratchet block as furthest-aft lead to prevent line overrides in drum when unfurling. Position ratchet block so line turns at least 90°.

Install so line is inside stanchion.

Lead line through block so ratchet makes clicking sound when pulling line to furl sail.

Tip: Make sure ratchet switch is in “on” position. If there is no clicking sound, lead line through block in opposite direction.

Lead line to furling line cleat in cockpit.

Furling Line Cleat

Install so line is angled as shown.

Note: As furling line lead changes, make sure line doesn't chafe against line guard. Rotate line guard if necessary.

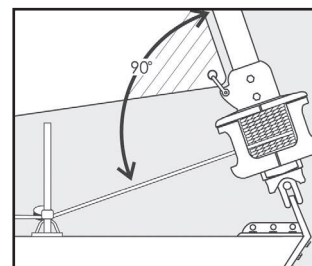

Furling line must enter drum at right angle to headstay.

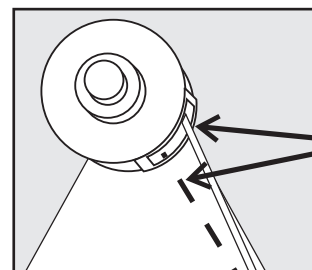

Furling line lead changes as amount of furling line on drum changes.

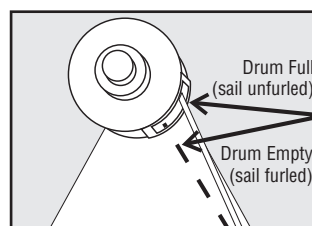
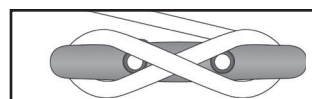

Halyard Wraps

The most serious problem with furling systems occurs when the jib halyard wraps around the headstay foil. Halyard wraps will keep you from furling or unfurling and may cause serious damage to the unit and the halyard.



WARNING! In severe cases, a halyard wrap can cause loss of control of boat and/or headstay can break suddenly. Make sure halyard is clear of top foil before using system.

If Halyard Wraps

If halyard wraps, do not force unit to turn. Attempt to open sail by carefully furling in and out a little at a time. If sail unfurls, lower it by releasing jib halyard. Severe halyard wraps can only be cleared by a professional going aloft and freeing halyard.

If sail will not furl or unfurl, try to remove jib sheets and manually wrap sail around headstay.



WARNING! Do not go aloft on boat's halyards if there has been a halyard wrap. Do not use boat. Damage to halyard, headstay, stay terminals, or connections as a result of a halyard wrap can cause these parts to break suddenly, causing the mast to fall while person is aloft. Sailing or motoring with boat after a wrap can result in the headstay breaking and mast falling. Before using boat, have a professional rigger inspect and replace parts as necessary using following methods.

A professional rigger must carefully inspect the masthead area using a secure hoisting method. Inform rigger that there has been a halyard wrap so he can avoid an accident by relying on standing rigging or halyards. Inspection must be done while rigger is suspended from a separate crane, or mast must be lowered to perform inspection. Some professionals may rig a new line through internal masthead sheaves to serve as a temporary headstay to hold mast in place. Wire, rod rigging, terminals, toggles, clevis pins or cotter pins must be inspected and replaced if they show any signs of damage.

Prevent Halyard Wraps

To prevent wraps, the halyard must exert a slight pull to the rear. This allows the foils to turn while halyard remains stationary.



WARNING! Sail must be fitted to foil length before using to prevent halyard wraps and possible headstay loss.

1. Halyard swivel should be within top 100 – 152 mm (4 – 6") of foil unless a halyard restrainer is used.
2. Halyard must pull slightly to rear (8 – 10°).
3. Halyard must be snug, but not too tight.

Test furler at dock. However, if water is smooth, an incorrect lead angle may not be apparent. Halyard wraps usually occur in wave action when lead angle is not correct. The 8 – 10° angle shown at right is critical.

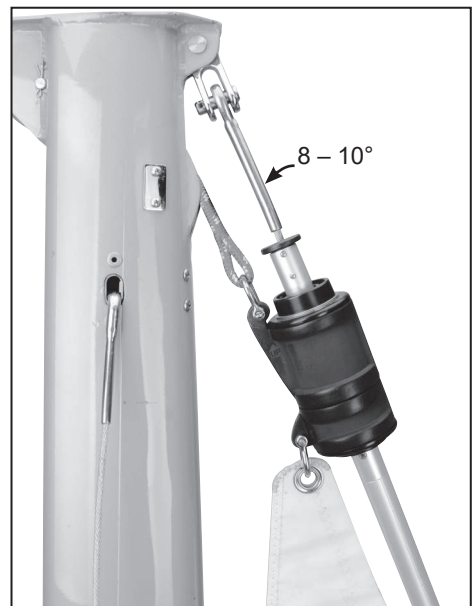

Pendants

If the your sail luff is not long enough to position halyard swivel high enough to create an 8 – 10° angle as shown, you must add a pendant. Pendants should be made of plastic-coated wire and be permanently attached so sail height will be correct. Adjustable-length pendants are not acceptable, as they might not be adjusted correctly during a sail change.

1. Raise sail, but do not attach tack shackle.
2. Position halyard swivel correctly near top of headstay.
3. Secure halyard.
4. Tie a piece of rope to sail tack.
5. Lead line through tack shackle on furling drum.
6. Tension sail.
7. Measure distance from tack shackle to sail tack and permanently attach pendant of this length to head of sail.
8. Repeat procedure for every jib in your sail inventory.



Halyard Deflector/Halyard Restrainer

To prevent wraps, jib halyard must pull slightly to rear. On most boats, halyard lead angle is acceptable if halyard swivel is raised to top of foil.

On some boats halyard sheaves are located too close to headstay and a halyard deflector or halyard restrainer must be used.

Halyard restrainers should be used only when required by masthead geometry. Restrainers tend to limit sail luff length, and can cause problems if not installed properly.

If your boat needs a halyard deflector (Unit 3 only), use part no. 7304 or a halyard restrainer (Unit 3 only), use part no. 945.

Restrainer should be mounted as high as possible on face of mast. Position restrainer so that foils will not hit it when under load.

The restrainer should deflect halyard as little as possible or you might experience difficulty in tensioning sail luff, have friction when furling, and cause possible damage to foils. To decrease deflection angles, shorten sail luff.

Tip: Boats used in charter service should have a halyard restrainer, regardless of masthead geometry.

Halyard Tension

The jib halyard should be firm, but not too tight.

Tip: The luff foil system supports sail along its length so halyard tension is used only to shape sails, not to support them. Use enough halyard tension to remove some wrinkles along luff of sail. Do not tension halyard enough to cause vertical wrinkles in luff of sail. Tension to adjust position of draft in sail to suit sailing conditions. Halyard should be firm, but not tight. If in doubt, release halyard tension. To protect sail, ease halyard when boat is not in use.



Unit 3 only



Unit 3 only

Halyard deflector



Unit 3
or
Unit 4

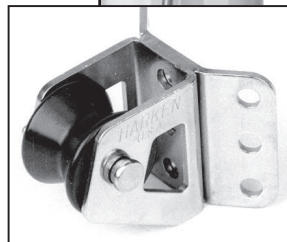

Halyard restrainer

Lash halyard, head of sail, and tack. A triple fisherman's knot is useful for this purpose. See www.harken.com/knottyingresources.

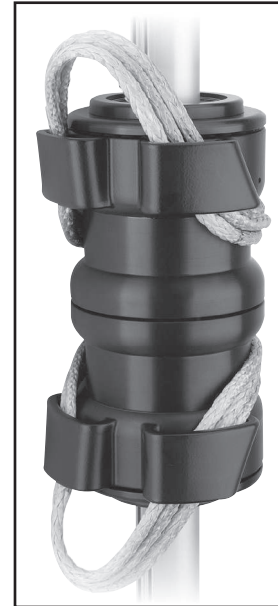

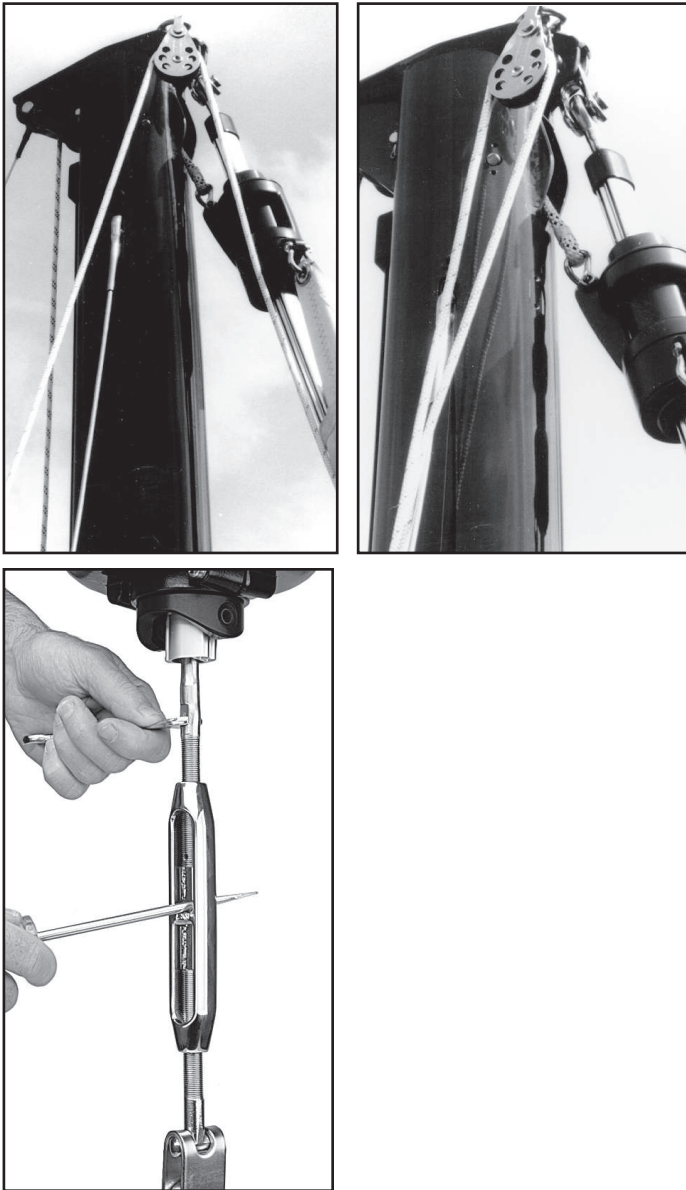

Spinnaker Halyards

Spinnaker halyards occasionally cause problems with furling.



WARNING! In severe cases, spinnaker halyards can jam furler, causing loss of control of boat. Make sure halyards are clear of top of foils and halyard swivel.

On many boats, it is not possible to attach spinnaker halyard to bow pulpit or it may be "sucked" into jib when furling.

On some boats the spinnaker halyard lays across headstay and will catch on halyard swivel, foils, or jib halyard. To prevent problems, it may be necessary to install a masthead bail to move spinnaker halyard block forward and to one side.

Boats with external halyards might find it necessary to flip both ends of spinnaker halyard behind spreaders to prevent fouling with furling system.

Headstay Tension

A furling system will work best if headstay is tight.

A loose headstay is difficult to rotate and can cause unusual wear on foil joints.

To adjust headstay tension, remove sail and furling line from unit and follow instructions on page 27.

Tip: Before adjusting headstay tension, slack mainsheet and vang.

Backstay Adjusters

Backstay adjusters allow headstay tension to vary so sail shape can be changed to match conditions. They permit a very tight headstay to be eased when boat is not in use. For best performance, consider adding a backstay adjuster; either a block and tackle, or a mechanical, or hydraulic adjuster like those offered by Harken.

Remember to keep headstay tight for best performance when furling or reefing.

If your boat is fitted with an adjuster be sure that it is tensioned before the halyard is tensioned. If not, backstay adjuster may increase halyard tension and could damage the sail or furling system.

Racing boats often slack the headstay completely when sailing downwind. Check to be sure that foil does not jam against upper headstay terminal when backstay is released. To prevent this, it might be necessary to shorten foil slightly.





Raise Sails

- 1) Install prefeeder by securely tying end of line to a deck fitting or to toggle below furler so it is 610 mm (2') below feeder.
- 2) Shackle tack of sail to drum. Install shackle so screw-pin head is on same side as sun cover.
- 3) Secure genoa sheets to clew of sail.
- 4) Attach genoa halyard to halyard swivel.
- 5) Pass luff tape through prefeeder and feeder into foil groove.
- 6) Attach head of sail or pendant at head of sail to halyard swivel.
- 7) Hoist sail.
- 8) Furl sail to check for possible halyard wraps. See pages 29 - 30.
- 9) See if sail will furl completely and still leave two wraps of line on spool and two wraps of sheets around sail. See "Secure Sail" on page 36.

Tip: New sails are often stiff and may hang up on prefeeder during raising. Do not force sail when it hangs up. Lower and remove twist. Sails "break in" with use and will become easier to raise.

Storm Sails

Most people will use one multi-purpose genoa for all their sailing, but it is not good seamanship to go offshore without storm sails.

Heavy-air working jibs and storm sails should be used with your unit. These sails need to have luff tape added to allow them to be raised in headstay foils.

These sails will generally require pendants to ensure that halyard swivel is properly positioned at top of headstay. See page 29.

Remember that heavy-air working jibs and storm jibs may be reefed and furled like any other sail.

Furl and Reef

To furl or reef, ease the jib sheets and pull furling line.

In very light air, it might be necessary to place some tension on jib sheet to insure a tight furl.

To furl in a breeze, ease sheets gradually and pull furling line in steps until sail is furled or reefed.

The furling line should pull readily. Depending upon wind strength, larger furlers may require use of a winch to furl. If sail will not furl, or if furling requires a great deal of effort, there is a problem with system.

Consult the Troubleshooting Guide on page 39. Do not use a winch to force a system to turn. If you are certain that the system is operating properly, you may use a winch to make furling easier.

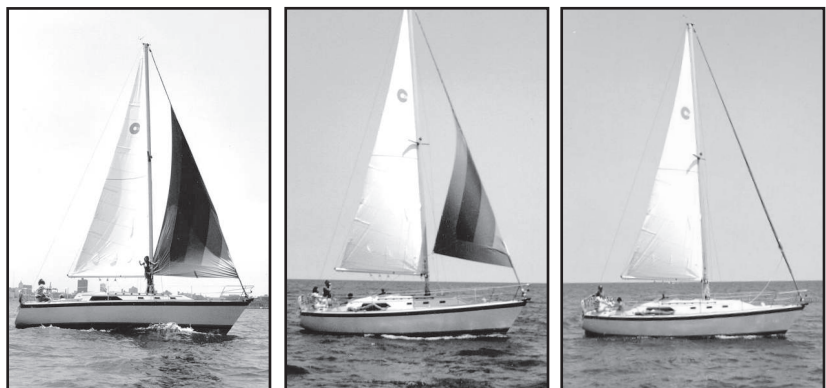

WARNING! Using a winch to furl when the halyard is wrapped may cause the headstay to fail, resulting in an accident.

Reef

A sail may be partially furled before you resume sailing. This is known as reefing.

Many sailors find it helpful to place marks on foot of sail so they can reef to a variety of predetermined jib sizes. This allows marks to be placed on jib lead tracks or toe rail so that lead block position can be changed to correspond to reefed jib.

Sails are generally reefed to balance the boat and to reduce heeling moment. Sails can also be reefed to improve visibility, or to slow boat while sailing in congested areas such as entering or leaving harbors.



Secure Sail

When furling the sail completely, make sure sheets and furling line are secured. Check amount of line on the spool compared to the furled sail before using the system.

A furled sail must have:

- a. Two to three wraps of the jib sheet around sail.
- b. Two wraps minimum of line wound on spool.
- c. Furling line securely cleated.
- d. Jib sheets securely wrapped on winch and held in self-tailing jaws.

Furl at dock with tension on sheets to duplicate furling in high wind.

Remember sails furled in light wind and left loosely secured can be a problem if wind increases.

IMPORTANT! Remove sail from furler if extreme winds are predicted, especially if boat is left unattended.

IMPORTANT! Check all points above—a, b, c, and d—when leaving boat to avoid damage to furler or boat.

A loosely rolled sail can catch wind in a storm. Sheets or furling lines can loosen as winds increase and allow furler to unroll. If there are no line wraps on spool, the line deadend can break the drum when the boat motors through waves.

Be sure mooring lines are not placed across furling line where they may cause chafe.



If you want to:

Add more wraps of jib sheet on furled sail.	Untie jib sheets and keep sail completely rolled. Secure with sail tie.	Turn spool to unroll a several of wraps of line.	Retie sheets.
Add more wraps of line on spool.		Turn spool to add a several of line.	

Race conversion allows use of both grooves for sail changes and tacking genoas on deck for use of maximum luff length genoas.

Halyard Swivel Below Feeder

Use halyard to lift halyard swivel up, and away from feeder. Loosen screw **one revolution only**. Slide screw up and hold. Remove feeder carefully—bottom end first. **Don't lose the feeder overboard!** Lower swivel onto drum assembly. Replace feeder.

Remove Feeder



Loosen screw **one revolution only**.

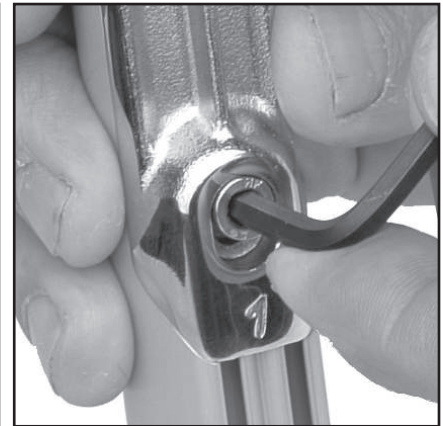

Slide screw up and hold.

Halyard Swivel Off Furler

Serious racers may want to remove the halyard swivel.

Note: It is not possible to remove halyard swivel on a unit with a Norseman/Sta-Lok® or rod adapter stud unless you disassemble terminal stud. Make sure you use a new Norseman/STA-LOK® wedge to reassemble Norseman/STA-LOK® fitting.

- 1) Remove drum assembly.
- 2) Rig a secure, temporary headstay.
- 3) Loosen backstay, mainsheet, and vang so headstay goes slack.
- 4) Remove clevis pin holding furling unit to chainplate.
- 5) See adjusting turnbuckle on page 27. Remove turnbuckle body and lower unit and slide off halyard swivel.
- 6) Reattach headstay to boat.

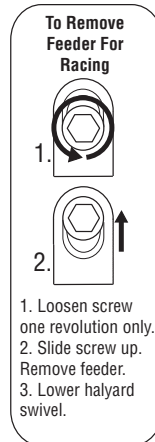

Carefully remove feeder-bottom end first. **Don't drop the feeder overboard!**

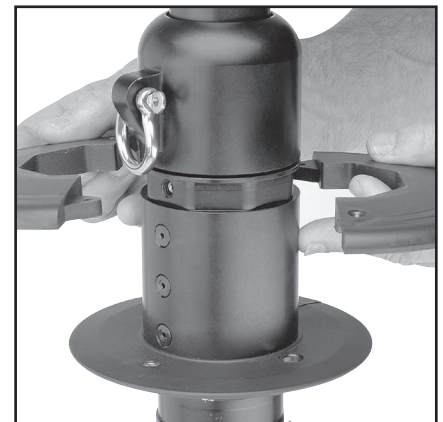
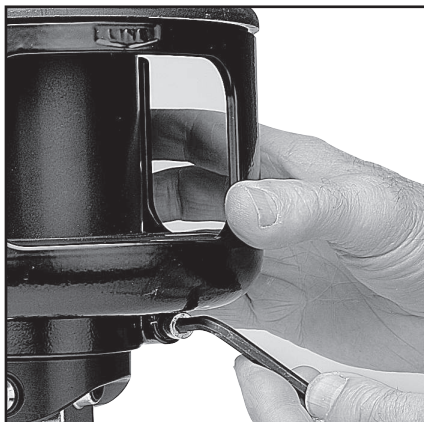

Remove Drum

- 1) Remove sail and unwind line from drum. Line can remain attached to drum.
- 2) Use 10 mm Allen wrench provided to remove two (2) screws on bottom of guard assembly. Remove two halves. Be careful—screws are not captive.
- 3) Use an Allen wrench to loosen four (4) screws in plastic cover and flange.

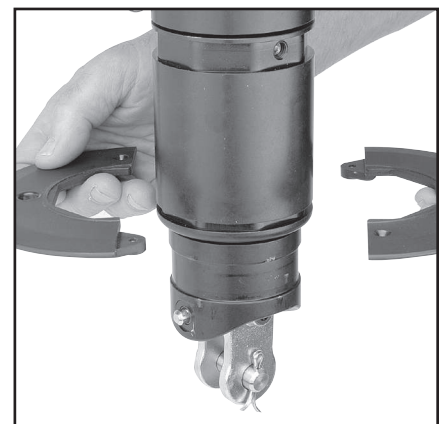
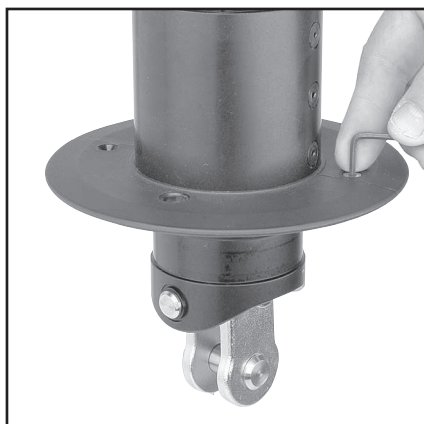

STA-LOK is a registered trademark of Barfield Engineering Company Ltd.

Maintenance



Clean/Inspect/Replace Line/Remove Furler

Clean and Lubricate

Keep unit clean. When you wash boat, flush unit with soap and fresh water. Occasionally lower sail and flush halyard swivel with soap and fresh water.

At least twice a year unit should be cleaned more thoroughly by removing line (first note direction of spool) and flushing bearings with soap and fresh water. After unit has dried, apply a dry spray lubricant such as McLube.

Foils can be cleaned by washing with soap and water. A scrap of luff tape may be run up foil to scrub inside grooves. If lubrication is required, spray a thin coat of McLube® SailKote™ dry lubricant on sail luff tapes away from boat deck.



WARNING! Do not spray foil on boat. McLube will cause slippery decks which can result in loss of footing, and falling overboard.



WARNING! Periodically inspect items listed below and any others as necessary. Failure to inspect can cause an accident.

Inspect

Inspect unit for signs of chafe, wear, or damage.

Inspect clevis and cotter pins below and inside drum assembly for signs of loosening. Check headstay tension for signs of loosening.

Inspect swage fitting and lower toggle for signs of stress corrosion.

Inspect Norseman or STA-LOK® terminal or rod terminal for signs of loosening.

Inspect all screws on unit to be sure they have not loosened.

Inspect foil to make sure that it has not dropped into drum assembly. Periodically inspect wire for signs of wear or unraveling.

Replace Line

Use 11 mm ($7/16$ ") diameter line. Use double-braid polyester line with good wear characteristics.

Storage – Mast Down

In areas where it freezes, do not store system where water can accumulate in foils. When water freezes it will rupture aluminum. Store foils under cover, with grooves facing down or on an angle so water will run out.

Storage/Transporting

Do not store or transport system with drum assembly extending beyond mast. Remove masthead clevis pin and shift furler up so drum assembly can be strapped securely to mast. Some people remove drum assembly and halyard swivel for storage and transport.

After Storage or Transport

After storing or transporting unit, clean thoroughly including ball bearings. See instructions above.

Loosen Foil Clamp Before Slacking Backstay

In order to prevent foils from locking against upper stay terminal when backstay is released, loosen foil clamp screws and lower foil before loosening backstay.

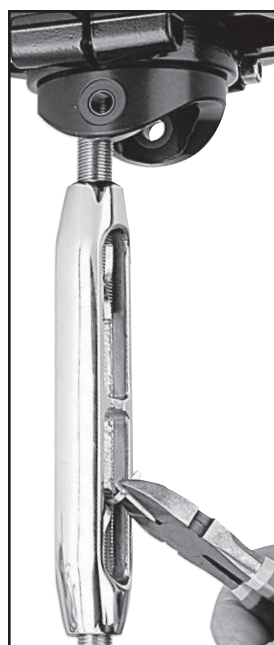

STA-LOK is a registered trademark of Barfield Engineering Company Ltd.
SailKote is a trademark of McLube®, a division of McGee Industries
McLube is a registered trademark of McGee® Industries, Inc.

Troubleshoot

Problem	Probable Cause	Solution
Sail will not furl or is difficult to furl.	Jib halyard is wrapping around headstay because angle between mast and halyard is too shallow	See installation instructions regarding optimal halyard angle. It may be necessary to mount a halyard restrainer on front of your mast to hold halyard to rear.
	Jib halyard is wrapping around the headstay because halyard swivel is too low.	See installation instructions regarding optimal halyard swivel height. A wire pendant may be needed at head of sail to raise halyard swivel to proper height.
	Jib halyard is too tight.	Ease jib halyard.
	Foils riding on turnbuckle.	Raise foils. See adjusting turnbuckle on page 27.
	Foils too high, binding on swage eye.	Lower foils until clear. See adjusting turnbuckle on page 27.
	Spare halyard is wrapping in sail as it furls.	Secure spare halyards away from furling headstay by flipping them behind spreaders
	Salt or dirt in bearings.	Flush bearings frequently with fresh water and a detergent solution.
	Furling line tangled in drum.	Overrides are best prevented by using a 2670 ratchet block as the last furling line lead to maintain proper drag on line while unfurling.
	Stop knot catching.	Make sure knot is a single overhand and is pushed up inside drum.
	Sail full of wind.	Luff completely before furling or reefing.
	Sail flogging too much.	Release a short length of sheet; pull some furling line and repeat.
	Jib sheets are not free.	Free jib sheets.
	Foil out of drum assembly.	Reinstall foil in drum assembly and tighten clamp screws.
	No wraps of furling line on drum.	Remove sheets. Rotate stay; wrap as much furling line on drum as possible.
	Line guard assembly has slipped down.	Tighten line guard assembly screws securely.
Line through 2670 ratchet backwards.	Rerun line.	
Halyard swivel installed upside down.	Remount swivel correctly.	
Sail will not unfurl or will not unfurl completely.	Jib halyard wraps around headstay because angle between mast and halyard is too shallow.	See installation instructions regarding optimal halyard angle. It may be necessary to mount a halyard restrainer on front of your mast to hold halyard to rear.
	Jib halyard is wraps around the headstay because the halyard swivel is too low.	See installation instructions regarding optimal halyard angle.
	Foils riding on turnbuckle.	Raise foils. See adjusting turnbuckle on page 27.
	Foils too high, binding on swage eye.	Lower foils. See adjusting turnbuckle on page 27.
	Jib halyard is too tight.	Ease jib halyard.
	Spare halyard wraps in sail as it furls.	Secure spare halyards away from furling headstay by flipping them behind spreaders.
	Salt or dirt in bearings.	Flush bearings frequently with fresh water and a detergent solution.
	Furling line is not free.	Free furling line.
Sail will not furl completely.	Insufficient furling line on drum.	Remove sheets. Rotate stay; wrap as much furling line on drum as possible.
	Too much line on drum.	Adjust amount of line on drum or change position of forward lead block to allow line to roll evenly on drum.
	Spare halyard catching in sail as it furls.	Move halyards away from furling headsail as above.
Headstay rotates in jerks or elliptically.	Insufficient tension on headstay.	Tighten headstay and/or backstay to eliminate sag in headstay.
Sail does not stay furled.	Sail not furled tightly on stay.	Maintain drag on sheets while furling.
	Furling line not secure.	Secure furling line.
Sail will not go up.	Luff tape will not go into groove.	Check luff tape for fraying. Check luff tape size.
	Sail catching at prefeeder.	Flake sail more loosely on deck.
	Dirt in groove.	Clean groove.
Sail will not raise completely or luff will not tension.	Halyard swivel is hitting end stop.	Luff of sail is too long and must be recut.
	Angle between halyard and mast is too sharp and halyard is pulling too much to the rear.	Halyard must be routed from a point higher on mast. This may require that any halyard turning blocks aloft be replaced or sail shortened.
Sail will not come down.	Halyard is wrapping on headstay.	Angle between headstay and halyard is too shallow and must be optimized per installation instructions.
	Halyard swivel off foil.	Sail luff too long or foil is too short or low and must be lengthened or raised.
Ultraviolet cover rolls up inside of sail.	Furling line is wrapped on drum in wrong direction.	Remove sheets. Pull line to remove all furling line from drum. Turn stay to rewind line on drum in opposite direction. Line guard and cowling alignment may need to be adjusted.
Line jams between guard and plastic spool plate.	Line is not led through windows.	Pull line through enclosed window.

Warranty
www.harken.com/manuals
 or call, write, email, or fax Harken, Inc.,
 Pewaukee, WI USA

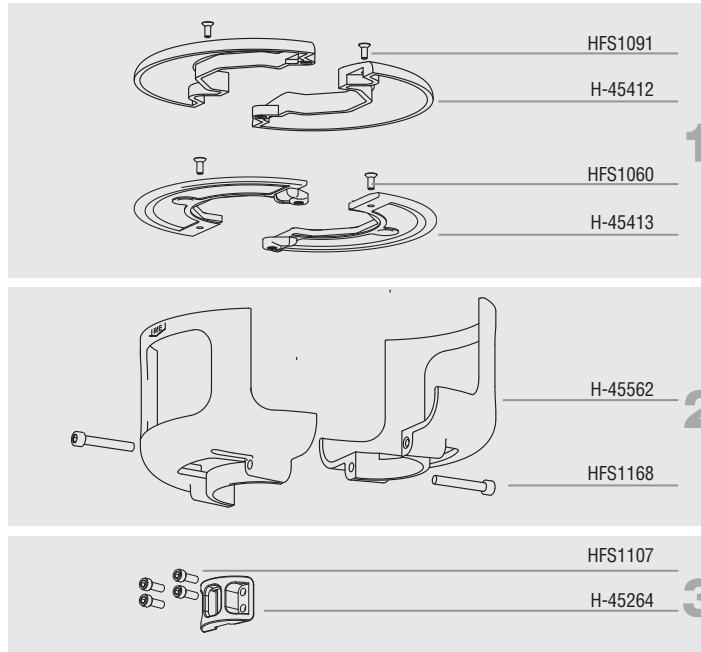

	Description	Order	Part No.
1	Top cover	2	H-45412
	Top cover screw (M5 X 16 mm FH)	2	HFS1091
	Bottom flange	2	H-45413
	Bottom flange screw (M5 X 12 mm FH)	2	HFS1060
2	Guard	2	H-45562
	Guard screw (M10 X 65 mm FH)	2	HFS1168
3	Clamp	1	H-45264
	Clamp screw (M8 X 25mm FH)	4	HFS1107
4	Hub assembly	1	7413.10BASE
	Ball plugs	5	H-38168
	Torlon® ball bearing (1/2")	25	MP-128
	Delrin® ball bearing (1/2")	100	MP-116

UNIT 3

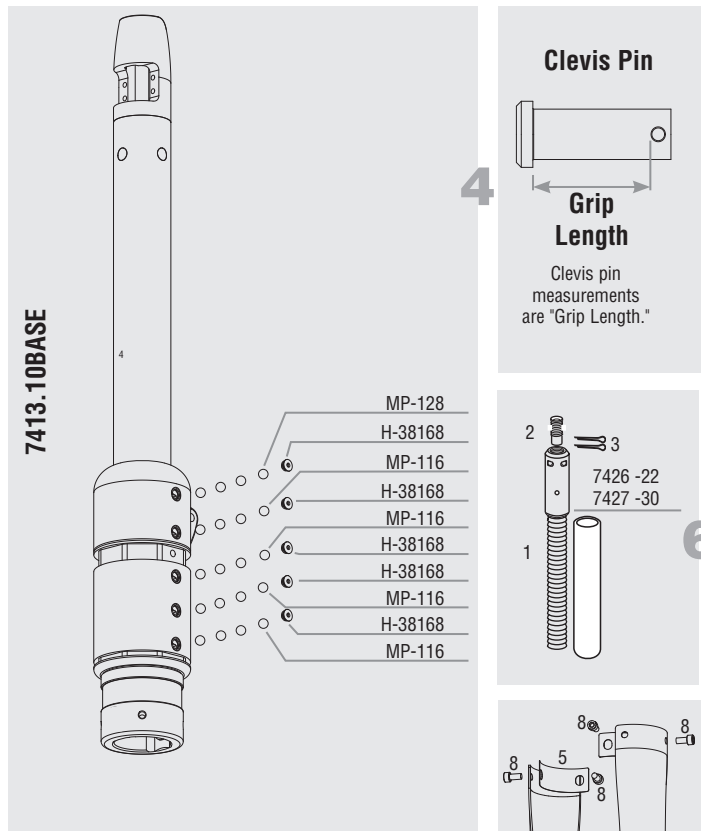

No.	Description	Order	Part No.
5	Jaw/jaw toggle with short link plates	1	7413.20 3/4
	1 Toggle	1	H-41489
	2 Plates	2	H-45334
	3 Crosspin	1	H-42583
	4 Clevis pin (3/4" X 1.766:GR 302SS)	1	H-42403
	5 Isolator	2	H-42585
	6 Cotter pin (5/32" X 1.250 18-8)	2	HFS203
	7 Nylon locking nut	2	HFS991
	8 Socket head cap screw	4	HFS903
6	Jaw/jaw toggle with short link plates	1	7413.20 7/8
	1 Toggle	1	H-42562
	2 Plates	2	H-45334
	3 Crosspin	1	H-42584
	4 Clevis pin (7/8" X 1.958" 302SS)	1	H-42404
	5 Isolator	2	H-42585
	6 Cotter pin (5/32" X 1.250 18-8)	2	HFS203
	7 Nylon locking nut	2	HFS991
	8 Socket head cap screw	4	HFS903

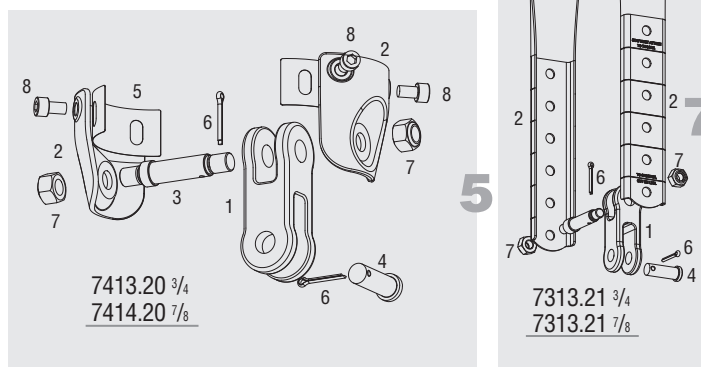

No.	Description	Order	Part No.	Part No.
6	Rod adapter stud (-22) w/nosepiece	1	7426 -22	
	1 Stud (main body)	1	H-41812	
	2 Nosepiece -22	1	H-41811	
	3 Cotter pin (3/32 x 1.750)	2	HFG319	
4 Stud cap 7/8" ID	1	HFG303		
7	Rod adapter stud (-30) w/nosepiece	1	7427 -30	
	1 Stud (main body)	1	H-41814	
	2 Nosepiece -30	1	H-41813	
	3 Cotter pin (3/32 x 1.750)	2	HFG319	
4 Stud cap 7/8" ID	1	HFG303		
7	Long link plate w/toggle		7313.21 3/4	7313.21 7/8
	1 Toggle	1	H-41489	H-42562
	2 Plates	2	H-42568	H-42568
	3 Upper clevis pin (custom)	1	H-42583	H-42584
	4 Lower clevis pin	1	H-42403	H-42404
	5 Isolator	2	H-42585	H-42585
	6 Cotter pin	2	HFS203	HFS203
	7 Nylon locking nut	2	HFS991	HFS991
8 Socket head cap screw	4	HFS903	HFS903	

Delrin is a registered trademark of E. I. du Pont de Nemours and Company or its affiliates. Torlon is a registered trademark of Solvay Advanced Polymers

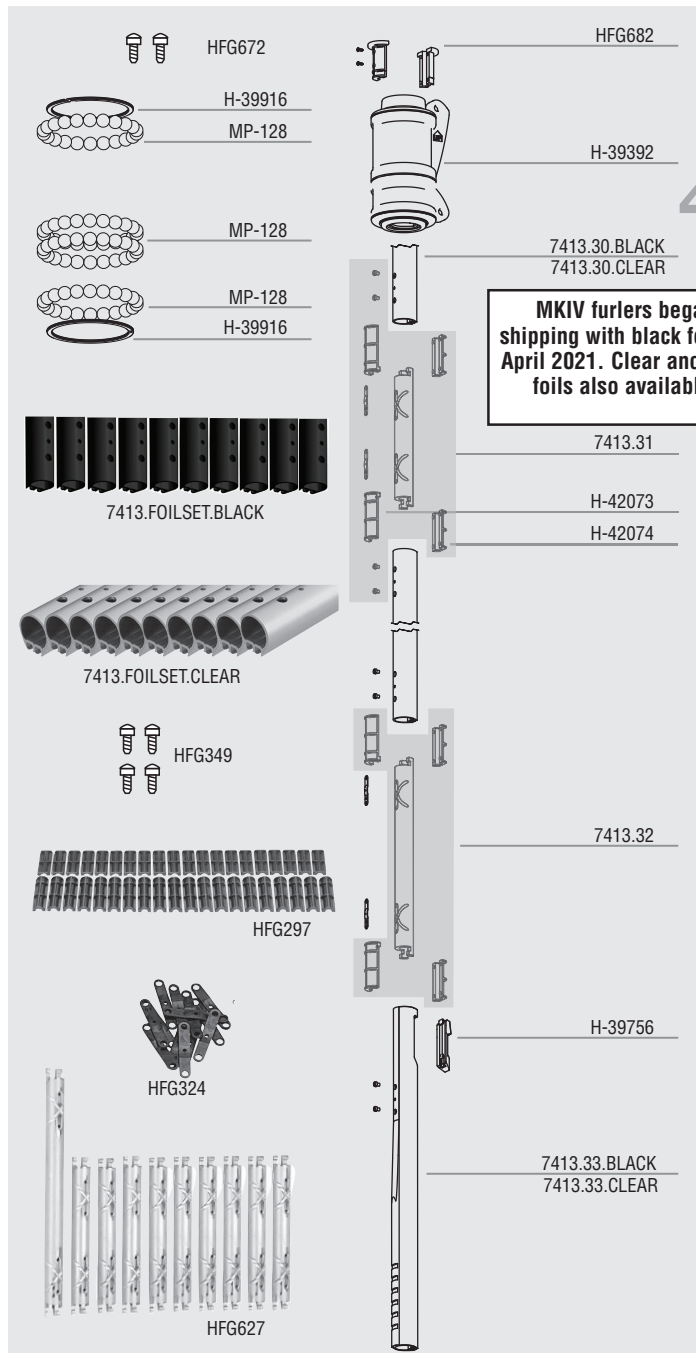

MKIV furlers began shipping with black foils in April 2021. Clear anodized foils also available.

4

4

Description	Order	Part No.
Trim cap set w/o screws	1	HFG682
Trim cap screw set	1	HFG672
Trim cap screw	2	HFS1127
Halyard swivel	1	H-39392
Clip/small ring for balls	2	H-39916
Torlon® ball bearings	88	MP-128
Foil set, less bottom foil - Standard	1	7413.FOILSET.BLACK
Foil (7' / 2.13 m luff)	10	7413.30.BLACK
Foil (2' / 610 mm) bottom - Standard	1	7413.33.BLACK
Foil set, less bottom foil - (Special order)	1	7413.FOILSET.CLEAR
Foil (7' / 2.13 m luff)	10	7413.30.CLEAR
Foil (2' / 610 mm) bottom - (Special order)	1	7413.33.CLEAR
Foil screw set	1	HFG349
Foil screw	46	HFS1106
Connector kit	1	7413.31
Connector (247 mm / 9 3/4")	1	—
Connector bushing A	2	H-42073
Connector bushing B	2	H-42074
Foil screw	2	HFS1106
Plastic connector wedge	2	H-39487
Bottom connector kit	1	7413.32
Bottom connector (355 mm / 14")	1	—
Connector bushing A	2	H-42073
Connector bushing B	2	H-42074
Connector set (No bushings, wedges or screws included)	1	HFG627
Connector (247 mm / 9 3/4")	9	—
Bottom connector (355 mm / 14")	1	—
Connector bushing set	1	HFG297
Connector bushing A (curved/longer)	20	H-42073
Connector bushing B (flat/shorter)	20	H-42074
Plastic connector wedge set	1	HFG324
Plastic connector wedge	22	H-39487
Feeder with screw and tab	1	H-39756
Feeder tab	1	H-38372A
Screw	1	HFS1130

UNIT 3

Description	Order	Part No.
5 Instruction manual	1	4673
Blue Loctite® adhesive	1	833
Red Loctite® adhesive	2	HFG739
5200 adhesive set	1	HFG725
5200 marine adhesive sealant	1	HFG722
Injector	1	HFG200 HFG201
Prefeeder	1	947

Description	Order	Part No.
6 Halyard restrainer (optional)	1	945
Sheave/ss inner race only	1	945A
Clevis pin (1/4" x 1.0625" 18-8)	1	HCP208
Bracket-large	1	HCP394
Cotter pin (1/16" x .500" 18-8)	1	HFS181
Halyard deflector	1	7304
Shackle	3	2124
Hex keys		
M10	1	HFG647
M6	1	HFG644
M4	1	HFG640
M3	1	HCP1089

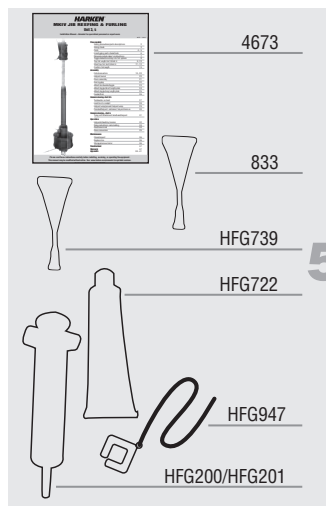

5

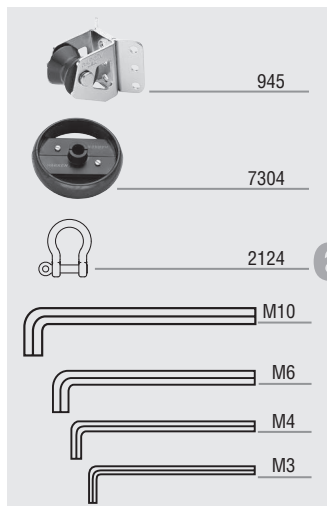

6

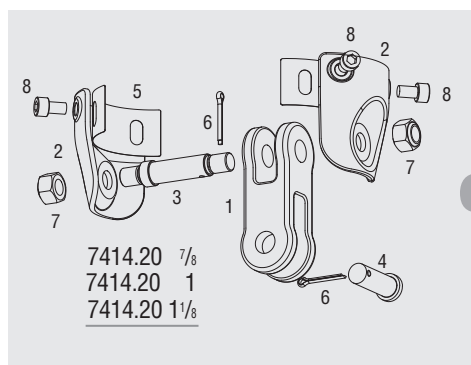
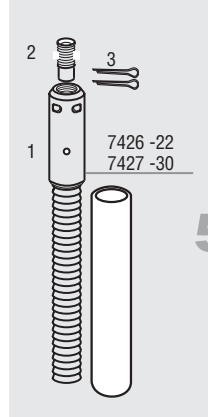
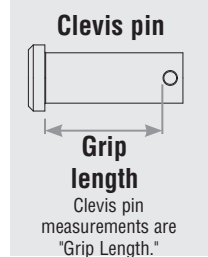
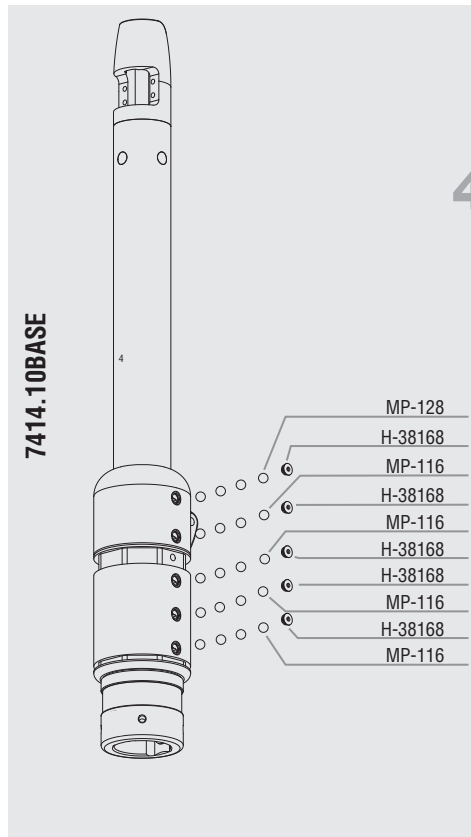
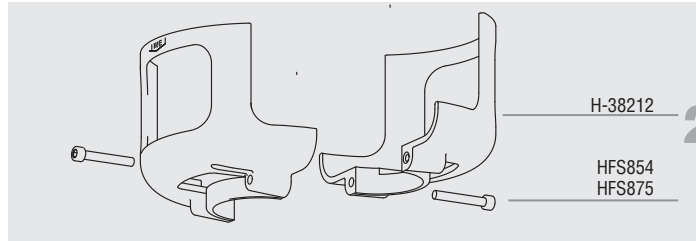
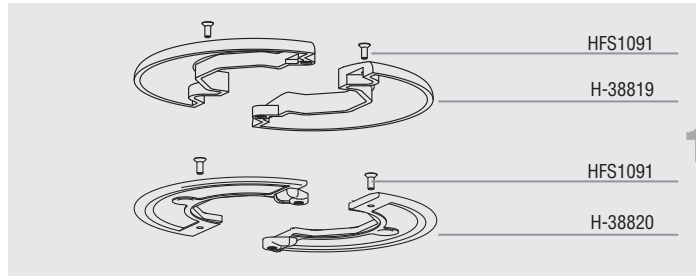

	Description	Order	Part No.
1	Top cover	2	H-38819
	Top cover screw	2	HFS1091
	Bottom flange	2	H-38820
	Bottom flange screw	2	HFS1091
2	Guard	2	H-38212
	Guard screw (FST-M12X1.75X70MM SHCS)	2	HFS1110
3	Clamp	1	H-45498
	Clamp screw (FST-M8X1.25X25MM SHCS A4 SS)	4	HFS1107
4	Hub assembly	1	7414.10BASE
	Ball plugs	5	H-38168
	Torlon® ball bearing (1/2")	25	MP-128
	Delrin® ball bearing (1/2")	97	MP-116

UNIT 4

No.	Description	Order	Part No.
5	Rod adapter stud (-30) w/nosepiece	1	7427 -30
	1 Stud (main body)	1	H-41814
	2 Nosepiece -30	1	H-41813
	3 Cotter pin (3/32 x 1.750)	2	HFG319
Rod adapter stud (-40) w/nosepiece	1 Stud (main body)	1	HFG303
	2 Nosepiece -40	1	H-47146
	3 Cotter pin (3/32 x 1.750)	1	H-47131
	3 Cotter pin (3/32 x 1.750)	2	HFG319
Rod adapter stud (-48) w/nosepiece	1 Stud (main body)	1	7429 -48
	2 Nosepiece -48	1	H-47147
	2 Nosepiece -48	1	H-47132
	3 Cotter pin (3/32 x 1.750)	2	HFG319

No.	Description	Order	Part No.
6	Jaw/jaw toggle with short link plates	1	7414.20 7/8
	1 Toggle	1	H-42562
	2 Plates	2	H-45449
	3 Crosspin	1	H-45439
	4 Clevis pin (7/8" X 1.958" 302SS)	1	H-42404
	5 Isolator	2	H-46403
	6 Cotter pin (5/32" X 1.250 18-8)	2	HFS203
	7 Nylon locking nut	2	HFS1122
Jaw/jaw toggle with short link plates	8 SH cap screw (FST-M12X1.75X20MM SHCS A4 SS)	4	HFS1177
	Jaw/jaw toggle with short link plates	1	7414.20 1
	1 Toggle	1	H-45427
	2 Plates	2	H-45449
	3 Crosspin	1	H-45440
	4 Clevis pin (1" X 2.231" A4 SS)	1	H-45435
	5 Isolator	2	H-46403
	6 Cotter pin (3/16" X 2 SS 316)	2	HFG743
7 Nylon locking nut	2	HFS1122	
Jaw/jaw toggle with short link plates	8 Socket head cap screw	4	HFS1177
	Jaw/jaw toggle with short link plates	1	7414.20 1 1/8
	1 Toggle	1	H-45428
	2 Plates	2	H-45449
	3 Crosspin	1	H-45441
	4 Clevis pin (1.125" X 2.526" A4 SS)	1	H-45436
	5 Isolator	2	H-46403
	6 Cotter pin (3/16" X 2 SS 316)	2	HFG743
7 Nylon locking nut	2	HFS1122	
8 Socket head cap screw	4	HFS1177	

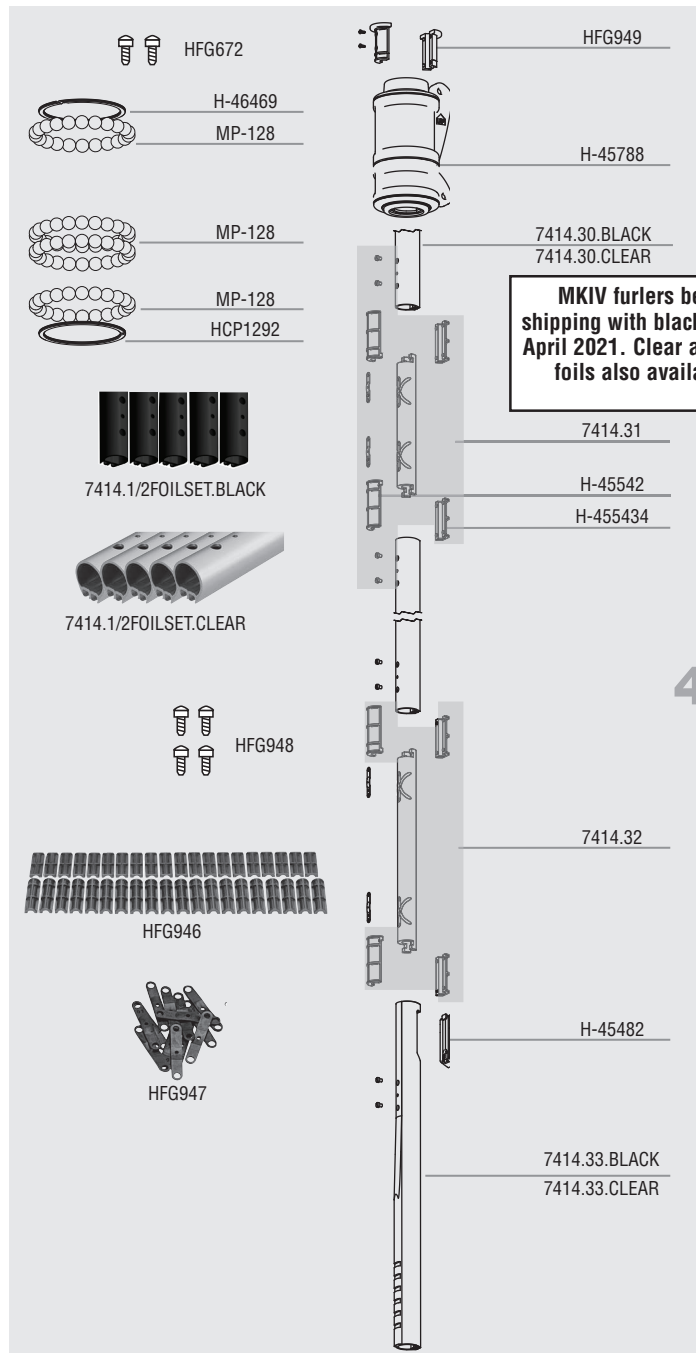

MKIV furlers began shipping with black foils in April 2021. Clear anodized foils also available.

4

Description	Order	Part No.
Trim cap set w/o screws	1	HFG949
Trim cap screw set	1	HFG672
Trim cap screw	2	HFS1127
Halyard swivel	1	H-45788
Clip/smalley ring for balls	1	H-46469
Clip/smalley ring for liners	1	HCP1292
Torlon® ball bearings (1/2")	100	MP-128
Foil set, less bottom foil - Standard	2	7414.1/2FOILSET.BLK
Foil (7' / 2.13 m luff) - Standard	10	7414.30.BLACK
Foil (2' / 610 mm) bottom - Standard	1	7414.33.BLACK
Foil set, less bottom foil - (Special order)	2	7414.1/2FOILSET.CLR
Foil (7' / 2.13 m luff) Special order	10	7414.30.CLEAR
Foil (2' / 610 mm) bottom (Special order)	1	7414.33.CLEAR
Foil screw set	1	HFG948
Foil screw	48	HFS1176
Connector kit	1	7414.31
Connector (272 mm / 10.7")	1	—
Connector bushing A	2	H-45542
Connector bushing B	2	H-45543
Foil screw	2	HFS1176
Plastic connector wedge	2	H-45509
Bottom connector kit	1	7414.32
Bottom connector (386 mm / 15.2")	1	—
Connector bushing A	2	H-45542
Connector bushing B	2	H-45543
Connector bushing set	1	HFG946
Connector bushing A (curved/longer)	23	H-45542
Connector bushing B (flat/shorter)	23	H-45543
Plastic connector wedge set	1	HFG947
Plastic connector wedge	24	H-45509
Feeder with Screw and Tab	1	H-45482
Feeder Tab	1	H-45480
Screw	1	HFS1175

UNIT 4

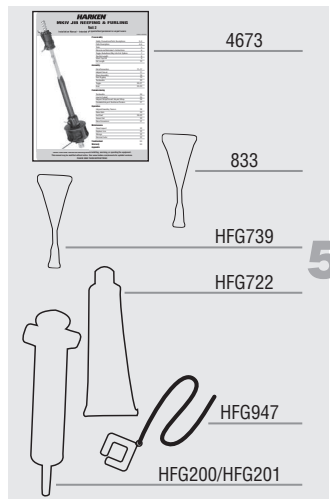

5

Description	Order	Part No.
Instruction manual	1	4673
Blue Loctite® adhesive	1	833
Red Loctite adhesive	2	HFG739
5200 adhesive set	1	HFG725
5200 marine adhesive sealant	1	HFG722
Injector	1	HFG200 HFG201
Prefeeder	1	947

Description	Order	Part No.
Hex keys		
M6	1	HFG644
M5	1	HFG643

6

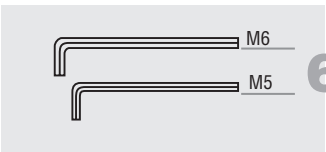

6

Torlon is a registered trademark of Solvay Advanced Polymers
Loctite is a trademark of Henkel AG & Company KGaA

AT THE FRONT



UNIT 3:
For boats 14–18 M

GIVE IN

To a more
powerful
Reflex™



The Reflex™ furling system has been proven to deliver very reliable, very smooth top-to-bottom spinnaker furls. How? The Reflex cable leverages its stainless mesh structure to immediately transfer rotational torque to the top swivel—where furls must start to end well. Now, there's Reflex Unit 3 with Dyneema® in its cable, scaled for halyard loads up to 4.5 tons. Imagine, sailing deep downwind with a very large, colorful sail that furls right up. Give in to that.



▶ WATCH VIDEO

AT THE FRONT **HARKEN**®

MKIV Unit 3 and 4

HARKEN®

Corporate Headquarters

N15W24983 Bluemound Rd, Pewaukee, WI 53072 USA
Telephone: (262) 691-3320 • Fax: (262) 701-5780
Web: www.harken.com • Email: harken@harken.com

Harken Australia Pty, Ltd.

1B Green Street, Brookvale, N.S.W. 2100, Australia
Telephone: (61) 2-8978-8666 • Fax: (61) 2-8978-8667
Web: harken.com.au • Email: info@harken.com.au

Harken France

ZA Port des Minimes, BP 3064, 17032 La Rochelle Cedex 1, France
Telephone: (33) 05.46.44.51.20 • Fax: (33) 05.46.44.25.70
Web: harken.fr • Email: info@harken.fr

Harken Italy S.p.A.

Via Marco Biagi, 14, 22070 Limido Comasco (CO) Italy
Telephone: (39) 031.3523511 • Fax: (39) 031.3520031
Web: harken.it • Email: info@harken.it

Harken New Zealand, Ltd.

158 Beaumont Street
Unit 11, Orams Marine Centre
Westhaven, Auckland, 1010, New Zealand
Telephone: (64) 9-303-3744 • Fax: (64) 9-307-7987
Web: harken.co.nz • Email: harken@harken.co.nz

Harken Polska Sp. z o.o.

ul. Przasnyska 6A, 01-756, Warszawa, Poland
Tel: +48 22 561 93 93 • Fax: +48 22 839 22 75
Web: harken.pl • Email: polska@harken.pl

Harken Sweden AB

Main Office and Harken Brandstore: Västmännagatan 81B
SE-113 26 Stockholm Sweden
Telephone: (46) 0303 61875 • Fax: (46) 0303 61876
Mailing address: Harken Sweden AB, Box 64, SE -440 30 Marstrand
Web: harken.se • Email: harken@harken.se

Harken UK, Ltd.

Bearing House, Ampress Lane, Lymington, Hampshire S041 8LW, England
Telephone: (44) 01590-689122 • Fax: (44) 01590-610274
Web: harken.co.uk • Email: enquiries@harken.co.uk

On Deck B.V.

Leimuiderdijk 478A, 2156 MX Weteringbrug, The Netherlands
Telephone: 31 71 331 3366 • Fax: 31 71 331 3387
Web: www.on-deck.nl • Email: allhands@on-deck.nl