

HARKEN®

MKIV OCEAN - JIB REEFING & FURLING

Unit 0

Installation Manual – Intended for specialized personnel or expert users



Preassembly

Safety Precautions/Parts Description	2
Sizing Check	3
Parts	4
Rigging Parts Check/Tools	5
Dimensions/Sailmaker's Instructions	6
Toggle Deductions/Stay Into Foil Options	7
Top Foil Length	8
Short Top Foil	9
Confirm Foil Length	10

Assembly

Foils/Connectors	11–14
Halyard Swivel and Drum Assembly	15
Rod Rigging	16
Turnbuckle/Toggle	17
Final/Feeder	18–19

Commissioning

Turnbuckle	20
Lead Line to Cockpit	21
Halyard Wrap/Prevent Halyard Wrap	22
Pendant/Halyard Restrainer/ Halyard Tension	23

Operation

Spinnaker Halyards/Headstay and Backstay Tension	24
Raise Sails	25
Furl/Reef	25–26
Secure Sail	26

Maintenance

Clean/Inspect	27
Replace Line	27
Storage/Remove Furler	27

Troubleshooting/Warranty **28**

Parts Lists **29–30**

Unit 0 Long Link Plates Supplement **33**

Please read these instructions carefully before installing, servicing, or operating the equipment.
This manual may be modified without notice. See: www.harken.com/en/support/manuals/ for updated versions.

PLEASE SAVE THESE INSTRUCTIONS

Introduction

This manual gives technical information on installation and service. This information is destined exclusively for specialized personnel or expert users. Installation, disassembling, and reassembling by personnel who are not experts may cause serious damage to property or injury to users and those in the vicinity of the product. If you do not understand an instruction contact Harken.

The user must have appropriate training in order to use this product.

Harken accepts no responsibility for damage or harm caused by not observing the safety requirements and instructions in this manual. See limited warranty, general warnings, and instructions in www.harken.com/en/general-warnings-instructions/

Purpose

Harken® Jib Reefing and Furling is designed for rolling sails on sailboats to reduce sail size or to completely roll so wind has little effect on the sail. Use of this product for other than normal sailboat applications is not covered by the limited warranty.

Safety Precautions



WARNING! This symbol alerts you to potential hazards that may result in death or serious injury if instructions are not followed. The message gives guidance on how to reduce the chance of injury. Strictly follow all instructions to avoid potential hazards that can result in death or serious injury. See www.harken.com/en/general-warnings-instructions/ for general warnings and instructions.



CAUTION! This symbol alerts you to potential hazards that may result in serious injury if these instructions are not followed. The message gives guidance on how to reduce the chance of injury.

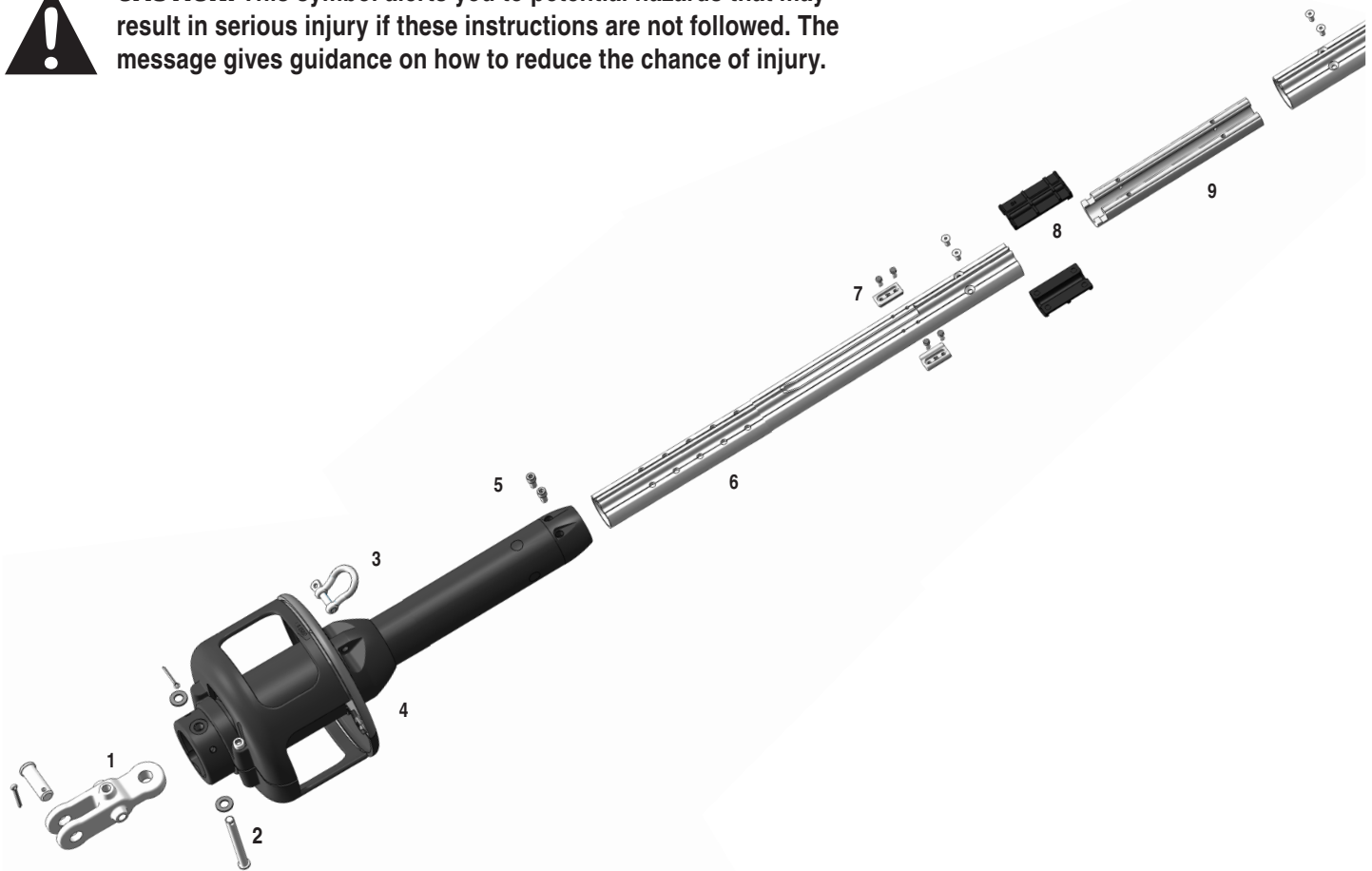

- 1) Toggle Assembly
- 2) Crosspin
- 3) Shackles
- 4) Drum Assembly

- 5) Foil Clamp Screws
- 6) 2' (610 mm) Bottom Foil
- 7) Feeder Assembly
- 8) Connector Bushing

- 9) Bottom Connector
- 10) 7' (2.13 m) Foil
- 11) Connector Screws
- 12) Connector

- 13) Halyard Swivel
- 14) Trim Cap
- 15) Trim Cap Screws

Safety Precautions

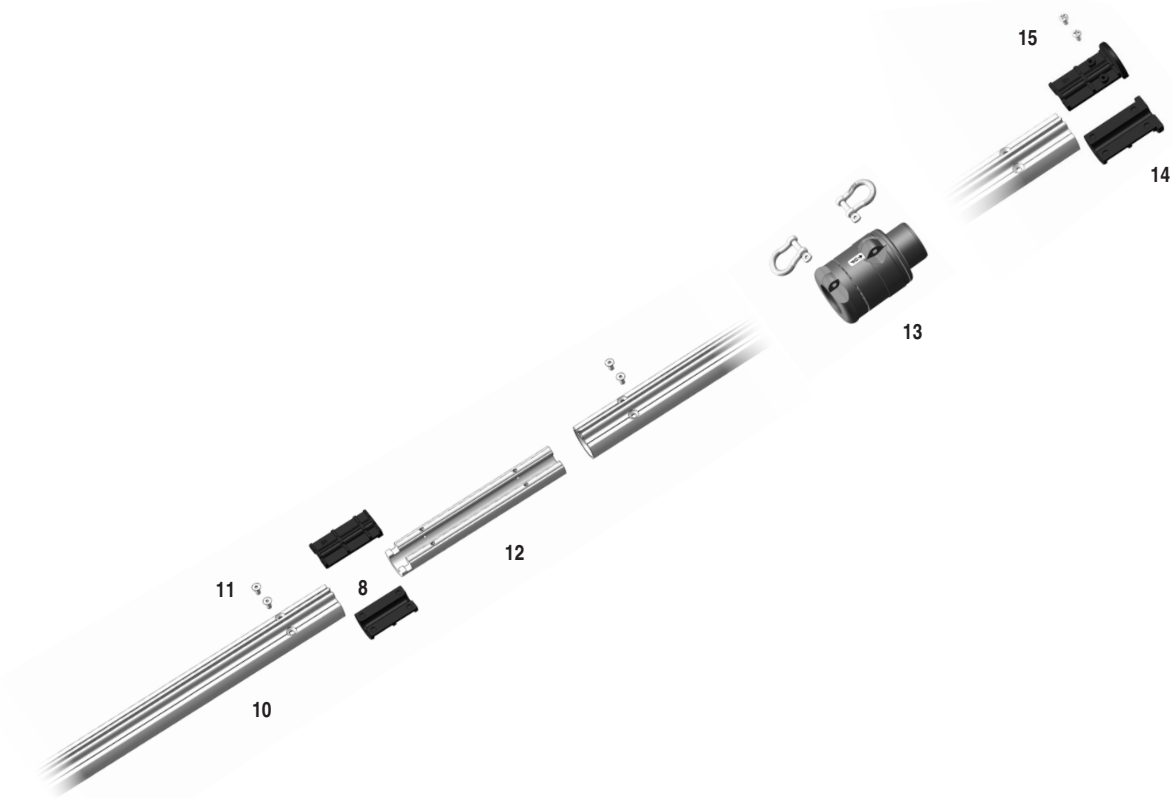

Size Check

1. Check headstay and clevis pin dimensions in chart below.



WARNING! Do not drill boat's chainplate or toggle. This may result in rig failure. Use the correct size toggle and clevis pin.

2. Harken does not recommend drilling boat's chainplate or toggle. In some cases bushings are available to fit boats with smaller clevis pin sizes.
3. Will drum fit on bow? See page 6. If necessary, use an additional toggle to slightly raise unit. To clear anchor use a Harken Long Link Plate which can be cut to various lengths.

Sizing Check			
Unit Part No.	Description	Wire Sizes	
7510.10	MKIV OCEAN Unit 0	5/32", 3/16", 7/32"	4 mm, 5 mm, 6 mm
		Rod Sizes	
		-4, -6	4.37 mm, 5.03 mm
Toggle Part No.	Description	Chainplate Clevis Pin Size	
7410.20 5/16	Eye/jaw reversible	5/16"	7.9 mm
7410.20 3/8	Eye/jaw reversible	3/8"	9.5 mm
7410.20 7/16	Eye/jaw reversible	7/16"	11.1 mm

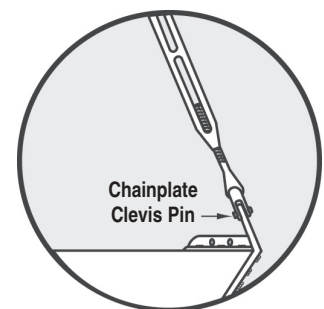



Halyard Swivel

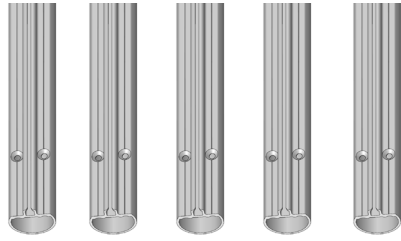

7' (2.13 m) Foils



Bottom Foil



Connectors



Connector Bushings



Foil Screws



Trim Cap



Trim Cap Screws



Feeder and Screws



Line



Hex Keys



Red Loctite®

Blue Loctite®



Drum Assembly

Main Components

Part No.	Quantity	Description
HFG992	1	Drum assembly with shackle
HFG993	1	Halyard swivel with shackles
7510.FOILSET	1	Foils (Standard package)
Includes	5	7510.30 Foils 7' (2.13 m)
	1	7510.33F 2' (610 mm) Bottom foil





Line

Part No.	Quantity	Description
HFG594	55' (16.8 m)	7 mm double braided polyester

Supplied Tools and Adhesives

Part No.	Quantity	Description
Various	3	Hex keys — 2.5 mm, 3 mm, and 5 mm
HFG739	1	Red Loctite® (for foil screws)
833	1	Blue Loctite® (for feeder screws)

Foil Assembly Components

Part No.	Quantity	Description
7510.31F	5	6" (152 mm) Connectors
HFG1014	1	Connector bushing set
Includes	5	H-83886 Bushing connector half - top 
	5	H-83887 Bushing connector half - bottom 
HFG1002	1	Foil screw set
Includes	22	HFS1379 Foil screws (extras included)
HFG1003	1	Trim cap set
Includes	1	H-83896 Trim cap half - top 
	1	H-83897 Trim cap half - bottom 
	3	HFS1127 Trim cap screws (Includes one extra)
HFG1004	1	Feeder set
Includes	2	H-83919 Feeder half
	5	HFS1407 Feeder screws (Includes one extra)

Ordered Separately (For longer headstays)

7510.30	1	Extra 7' (2.13 m) Foil
7510.31	1	Extra Connector with Bushings and Screws

1. Harken toggle assembly required. Sold separately.
2. Mating turnbuckle components must be purchased separately.
3. Headstay may require cutting and shortening to fit Harken toggle. Headstay may remain uncut by replacing lower stud of turnbuckle with stud/eye thus eliminating extra toggle.
4. Rod rigging requires Harken rod adapter stud.
5. Order Harken 7404 Lead Block Kit. Fits 1" (25 mm) stanchions.



WARNING! A stay that is old or damaged may break suddenly, causing an accident. Headstay condition should be checked by a professional rigger before reusing.

**ALL UNITS
Harken Toggle (Sold Separately)**



Eye/Jaw Toggle Reversible
7410.20 5/16
7410.20 3/8
7410.20 7/16

**ROD RIGGING
Harken Rod Adapter
Stud Required
(Sold Separately)**



Thread
7/16-20 RH

7420 -4
7421 -6
Rod Adapter Studs

**7404 Lead Block Kit
(Sold Separately)**



**Includes 3 x 7403; 1 x 7401;
1 x 7402; 1 Horn Cleat**



Tools You Will Need



1. Long tape measure	6. Side cutters	11. Rigging or black tape
2. Short tape measure	7. Rat-tail file	12. Center Punch
3. Power drill	8. Hex keys (provided)	13. Hammer
4. Drill bit – 1/8" (3 mm)	9. Slotted/phillips screwdrivers	
5. Hacksaw	10. Needle-nose pliers	

Luff Length

Note offsets above and below sail.

A shorter luff may be required if a halyard restrainer is necessary (page 23) or a toggle or long toggle assembly is used to raise drum.

If luff of sail is not long enough to put halyard swivel near top of headstay foil, a pendant must be added (see page 23).

Tack Setback

Note setback for tack shackle and cut the sail accordingly. Feeder height depends upon up/down foil position in lower unit.

Luff Tape Size -6 (5 mm or 6/32")

J – Finished luff tape size: 5.5 mm (0.215")

K – Luff rope size: 4.8 mm (6/32", 3/16")

L – Max Ø in sail groove: 6.1 mm (0.24")

M – Gap in sail groove: 2.4 mm (0.096")

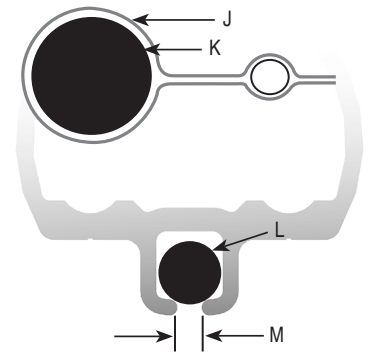

Luff Tape Length

Note feeder height and extend bottom of luff tape downward so it is below feeder. This will prevent luff tape from catching in feeder as sail is lowered.

Tack and Head Shackles

Make sure tack and head shackles fit sail rings. Minimum inside dimensions of standard head and tack shackles are:

(A) 1-1/16" (27 mm)

(B) 1/2" (13 mm)

Sun cover

Sun covers may be installed on either side of the sail. Be sure to match other sails in the customer's inventory.

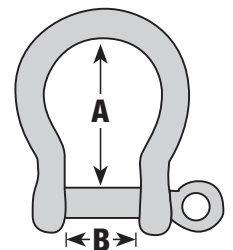

*These three dimensions are for the 7/16" (11.1 mm) toggle. Deduct 5/16" (8 mm) from these dimensions for smaller toggles: 5/16" (7.9 mm) or 3/8" (9.5 mm)

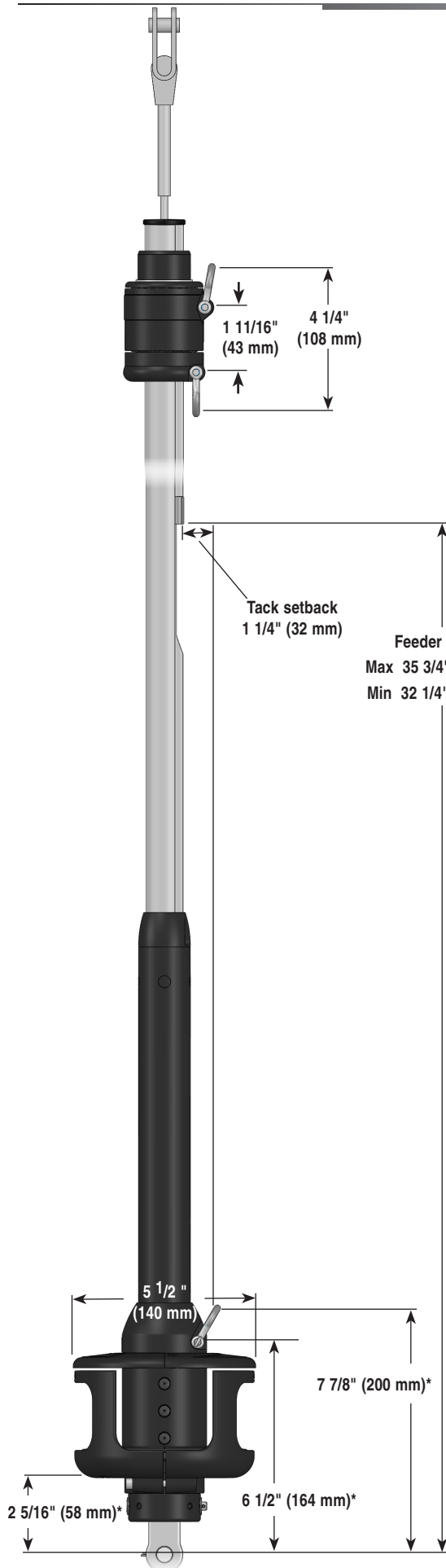

Use dimensions of Harken toggle below to build stay to correct length.

Tip: Turnbuckles should be 1/2 to 2/3 open to allow shortening for new wire stretch and for fine-tuning mast rake.

Clevis Pin	Pin-to-Pin Length
5/16" (8 mm)	2-1/8" (54 mm)
3/8" (9.5 mm)	2-1/4" (56.5 mm)
7/16" (11.1 mm)	2-7/8" (73 mm)

Labels in diagram: Crosspin, Fork Attachment, Tang Attachment.

Inset text: For tang-down installations, switch plugs to this position.

Dimensions for tang-down: 2-1/8" (54 mm) or 2-1/4" (56.5 mm) or 2-7/8" (73 mm).

Most boats have a chainplate with a single tang. If boat has two plates forming a jaw, reverse eye/jaw toggle so eye is down.

IMPORTANT! Remove black plastic caps and install them so crosspin will be at 90 degrees to lower clevis pin.

Options for Snaking Stay into Foils

1. Swage stud at end of wire.
2. Open end of wire and install Norseman or Sta-Lok® stud after foil is assembled.
3. When using smaller wires, marine eye may fit. See page 12.
4. Rod adapter nosepiece for Harken rod adapter stud.

WARNING! Using a threaded nosepiece with only adhesive at the upper rod eye terminal may result in headstay system failure which can cause an accident, damage to your vessel, personal injury, or death. See www.harken.com/en/general-warnings-instructions/ for additional safety information.



Preassembly

Top Foil Length

Measure A and add to this chart and "length chart" below		
	Inches	mm
A		
B	.4*	10*
E	24.0	610
F	13.9	354
G		
Total A+B+E+F+G		

Make sure upper measurement points of A and pin-to-pin are the same.

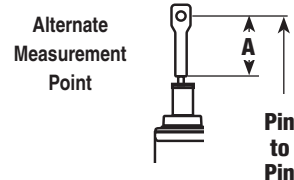

*Add 1" (25 mm) if using a 7301 halyard deflector. See page 10.



1	Pin-to-Pin Length	
2	Subtract ABEFG	-
3	Result (Pin-to-Pin - ABEFG)	
4	Subtract D	-
To find "D" pick number from chart below that is closest to, but not greater than total from step 3.		
	Inches	mm
	3 X 84 = 252	3 x 2133.6 = 6400.8
	4 X 84 = 336	4 x 2133.6 = 8534.4
	5 X 84 = 420	5 x 2133.6 = 10668
	6 X 84 = 504	6 x 2133.6 = 12801.6
Example-If result from Step 3 is: 500 inches "D" = 420 inches 12,000 mm "D" = 10,668 mm		
5	Result (C) Top Foil Length	

IMPORTANT! If top foil length is less than 3" (76 mm), go to page 9.

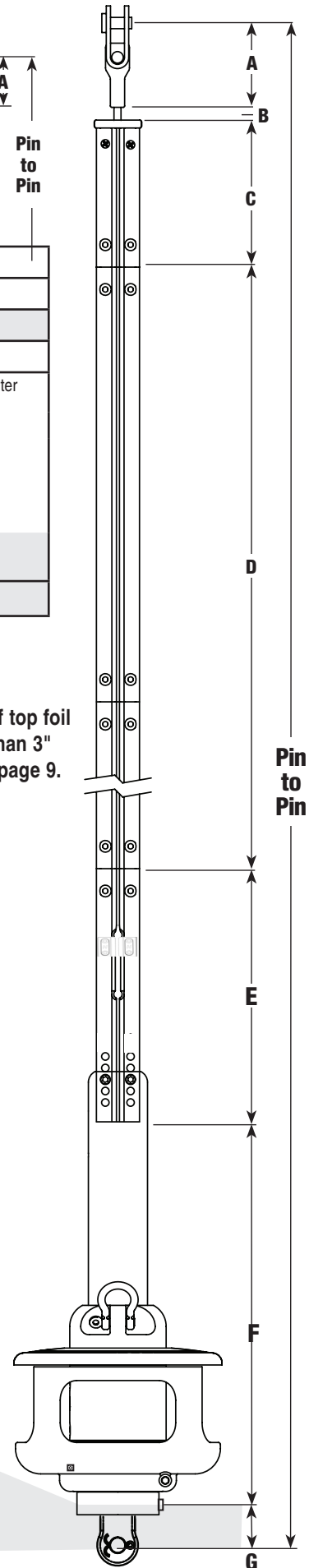

Length Check

After completing worksheet above fill in A, C, D and G below. Add "A" through "G" to confirm total equals your pin-to-pin measurement.

Pin-to-Pin Length Worksheet			
Dimensions	Inches	mm	
A Center of Pin to Bottom of Terminal			
B Bottom of Terminal to Top of Foil	.4	10	
C Top Foil Length			
D Number of Foils _____ x 84" (2133.6 mm)			
E Bottom Foil	24.0	610	
F Bottom of Foil to Crosspin	13.9	354	
G Crosspin to Clevis Pin			
Pin-to-Pin Length			

G Toggle Distance from Lower Clevis Pin to Crosspin Hole					
Toggle Part No.	Type	Clevis Pin		G Distance	
7410.20 5/16	Eye/Jaw	5/16"	7.9 mm	1.1"	27 mm
7410.20 3/8	Eye/Jaw	3/8"	9.5 mm	1.3"	33 mm
7410.20 7/16	Eye/Jaw	7/16"	11.1 mm	1.4"	36 mm

Use one of the following special techniques for foils 4 13/16" (122 mm) or under to ensure sufficient bearing surface for foil in area of halyard swivel.

Unit 0

Top foil length from worksheet:
4-5/8" - 3-7/8" (117 — 98 mm)

No change necessary.

Unit 0

Top foil length from worksheet:
3-13/16" - 2-7/8" (97 – 73 mm)

Cut top trim cap to 3 13/16" (97 mm) as shown above.

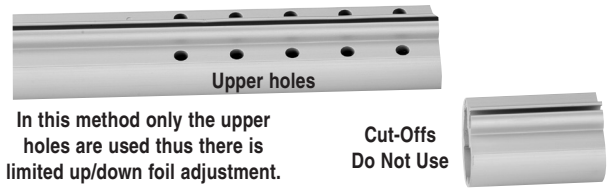

Unit 0	
Top foil length from worksheet:	
2-3/4" - 1-1/2" (70 – 38 mm)	
Actual Top Foil	
3-13/16" (97 mm)	

Do not cut top foil to length from worksheet. Cut top foil to 3-13/16" (97 mm) and shorten trim cap by 3/4" (19 mm) as shown at left. Shorten bottom foil per chart below. Foil will be clamped in upper holes.

Top foil length from worksheet		Actual top foil		Shorten bottom of bottom foil by this amount	
in	mm	in	mm	in	mm
2-3/4	70	3-13/16	97	1	25
2-1/4	57	3-13/16	97	1-1/2	38
1-3/4	44	3-13/16	97	2	51
1-1/4	32	3-13/16	97	2-1/2	64

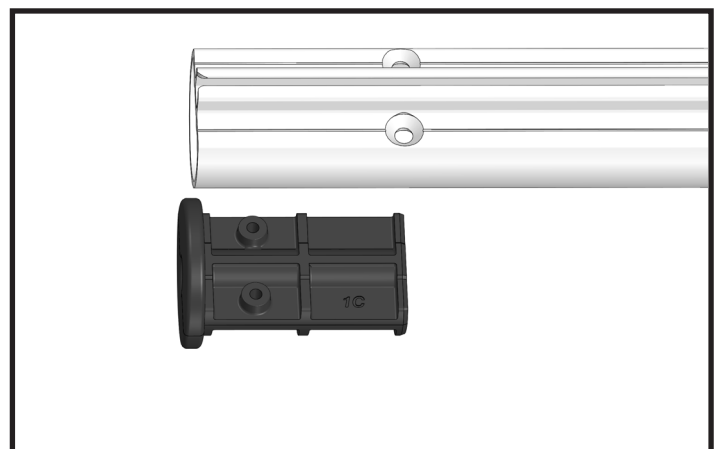

Unit 0	
Top foil length from worksheet:	
1" - 1/2" (25 – 13 mm)	
Do not use short top foil. Use full length foil and clamp foil higher in drum assembly.	

Confirm foil length by laying foils alongside stay with turnbuckle components.

Pull stay out so it is straight. Attach Harken toggle to bottom of stay. Make sure toggle straps are straight. Adjust turnbuckle so that length of stay with Harken toggle will fit boat. Ideally, turnbuckle will be half to two-thirds open to allow for rig adjustment.

Line up drum assembly so holes below drum line up with holes in Harken toggle. Make sure toggle is tensioned when measuring.

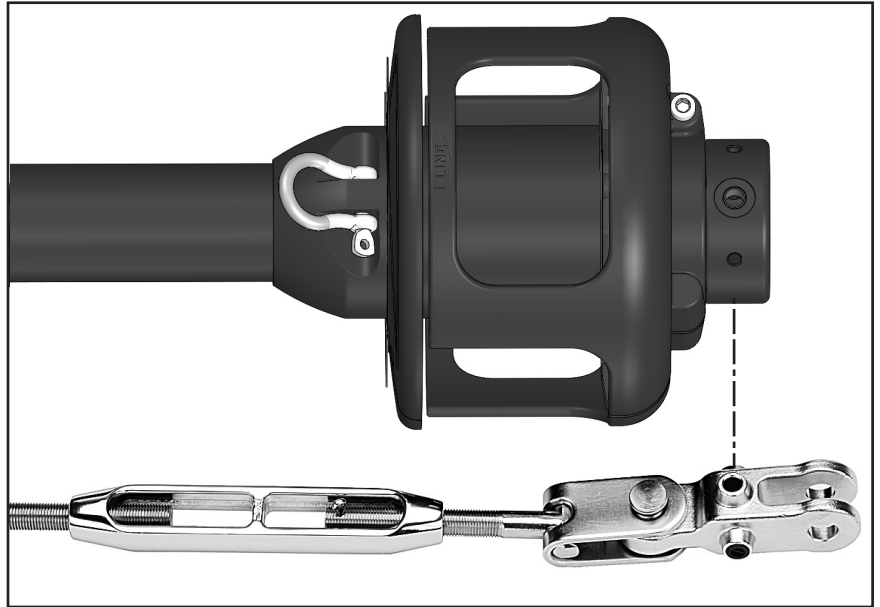

Line up bottom foil so foil clamp is just above or below center of notches in bottom foil.

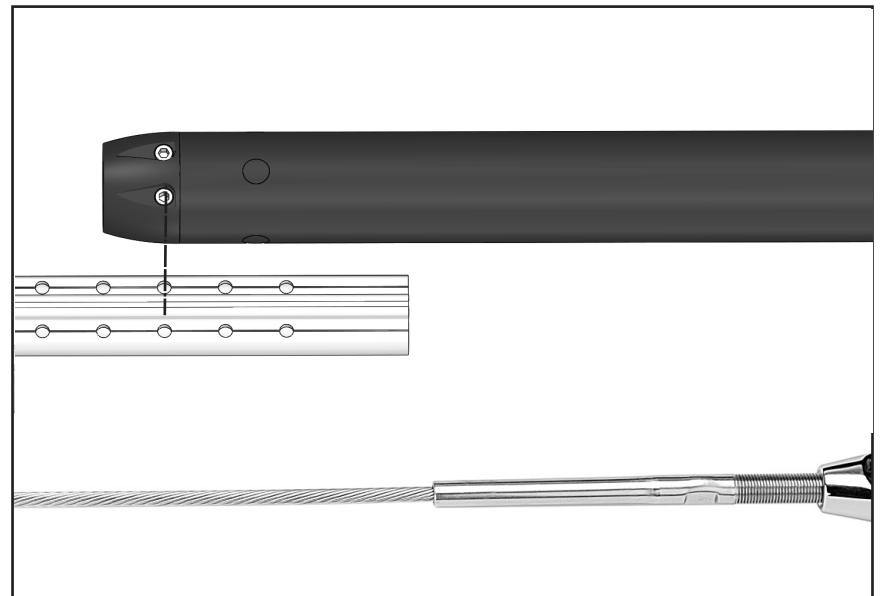

Note: Position top foil so that with top cap the foil will ride 3/8" (10 mm) below terminal. If wire fitting at top of stay is swage, foil must ride just below shoulder of swage. Mark cut line on foil. Wrap tape around foil as a guide so cut is straight.

No halyard deflector — 3/8" (10 mm)
With halyard deflector 1-3/8" (35 mm)

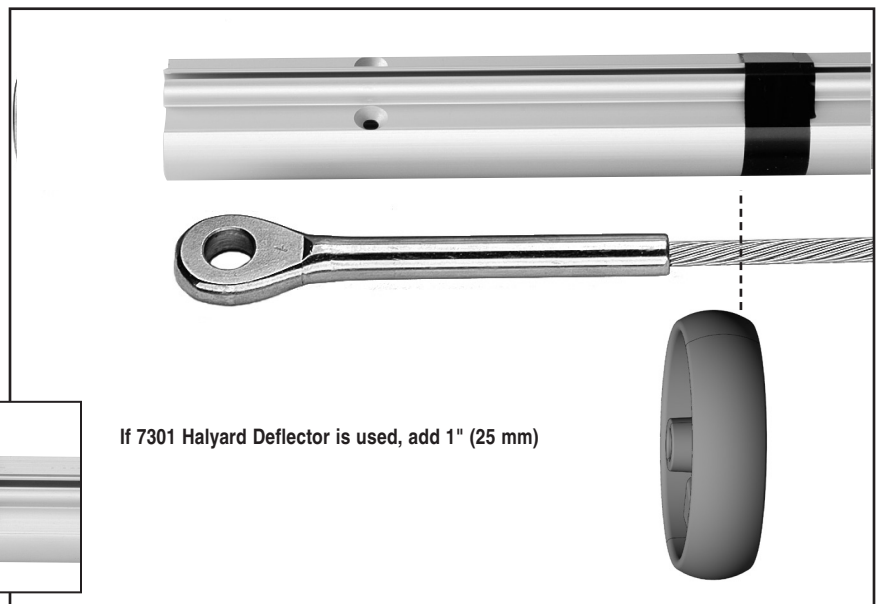

If 7301 Halyard Deflector is used, add 1" (25 mm)

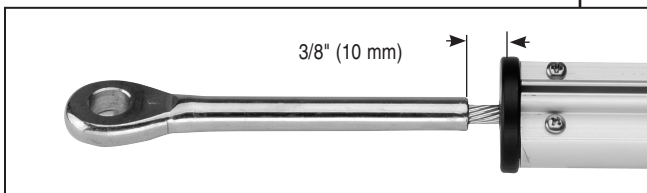

Cut foil to length using hacksaw. Deburr inside edge using rat-tail file.

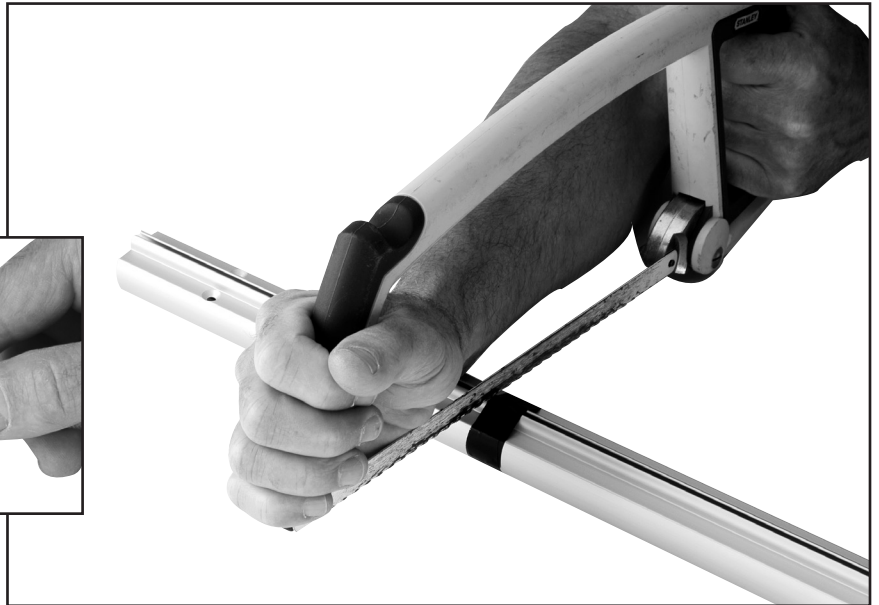
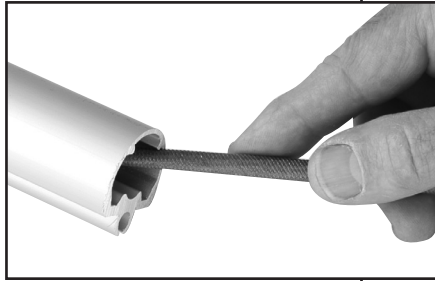

Mark the location of the trim cap screws at the cut end of the top foil.

Location: 7/16" (11.4 mm) down from top of foil and 5/16" (8 mm) from center of the sail groove. See dimensions below.

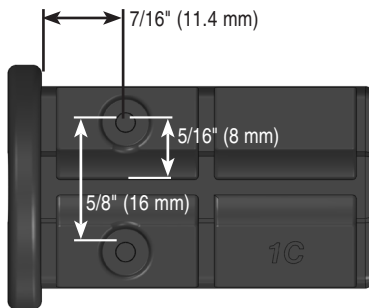

Drill two 1/8" (3 mm) holes in foil for self-tapping screws.

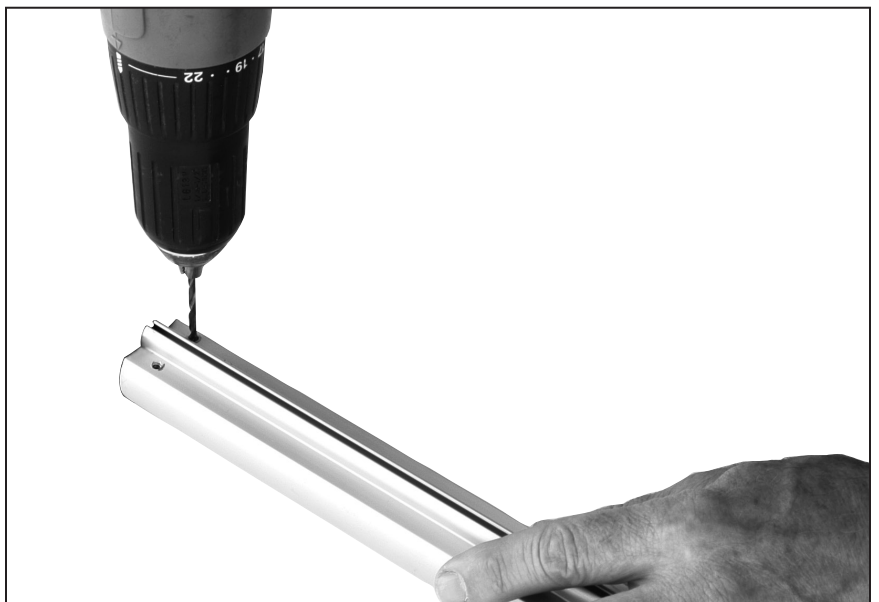

The following instructions cover installing foils on stay starting from the bottom. Foils slide over a swage stud fitting or wire end where a Norseman-/Sta-Lok®-type stud is used after foil assembly.

Tip: In some cases foils can slide over a marine eye. This allows other assembly options:

- Assembly from both ends for faster assembly
- Over a marine eye located on the bottom of the stay
- From the top if lower terminal is part of turnbuckle

Check fit of marine eye before proceeding. This will generally work with smaller wires within the unit's rigging specifications.

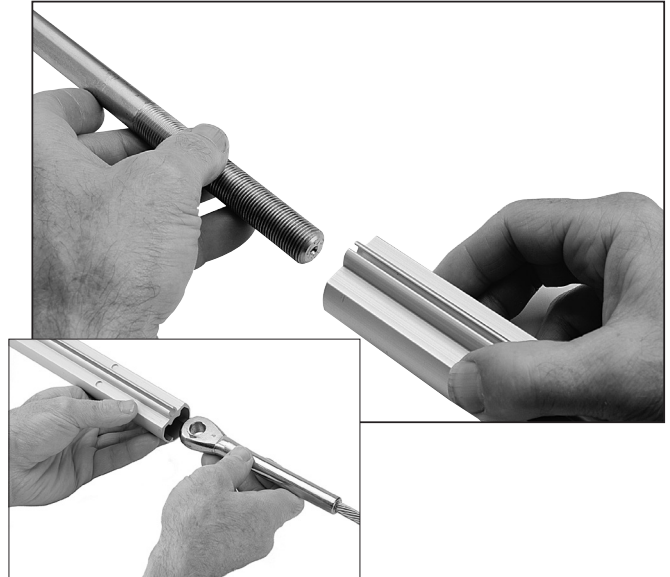

Alternate assembly over marine eye

Place halves of trim cap over wire and insert into top foil. Use a small hammer to tap in place if necessary.

Tip: With foil groove up, have screw holes on the upper half.

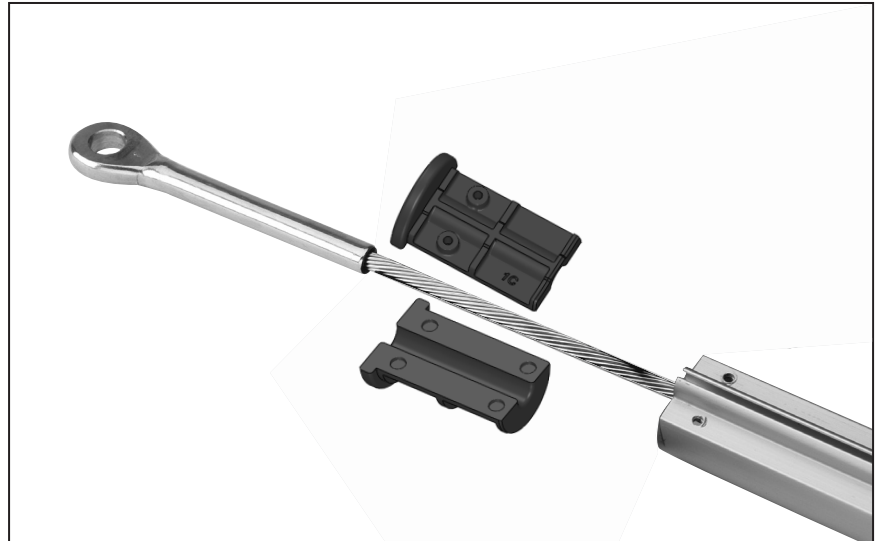

Install self-tapping trim cap screws.



Assemble Halyard Deflector if used.

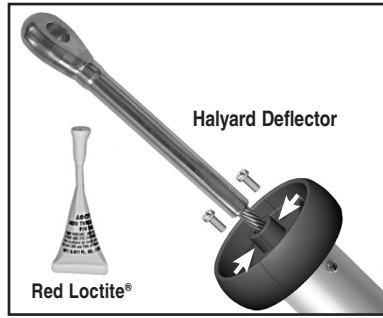

Put a drop of red Loctite® in screw holes. Place connector on wire with hooked side down.

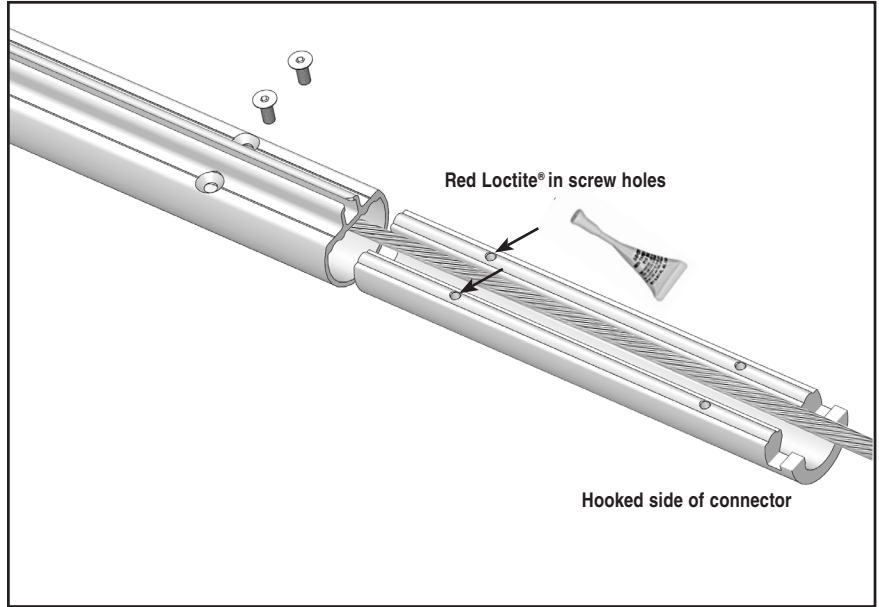

Use a hex key wrench to securely tighten screws.

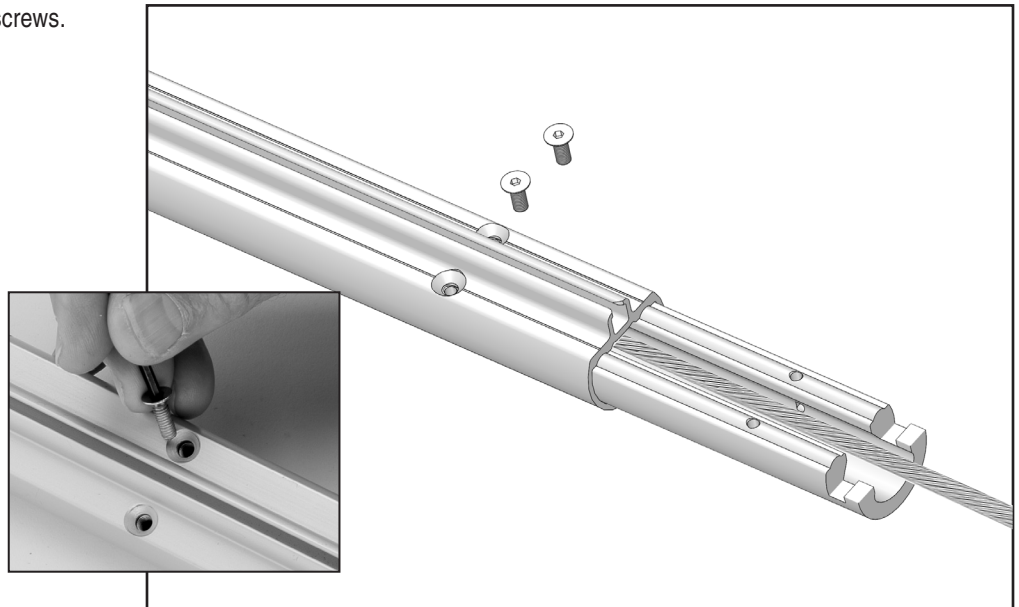

Sandwich bushings on wire, mating hook of plastic bushing with connector and mating with four recesses in bottom part of bushing.

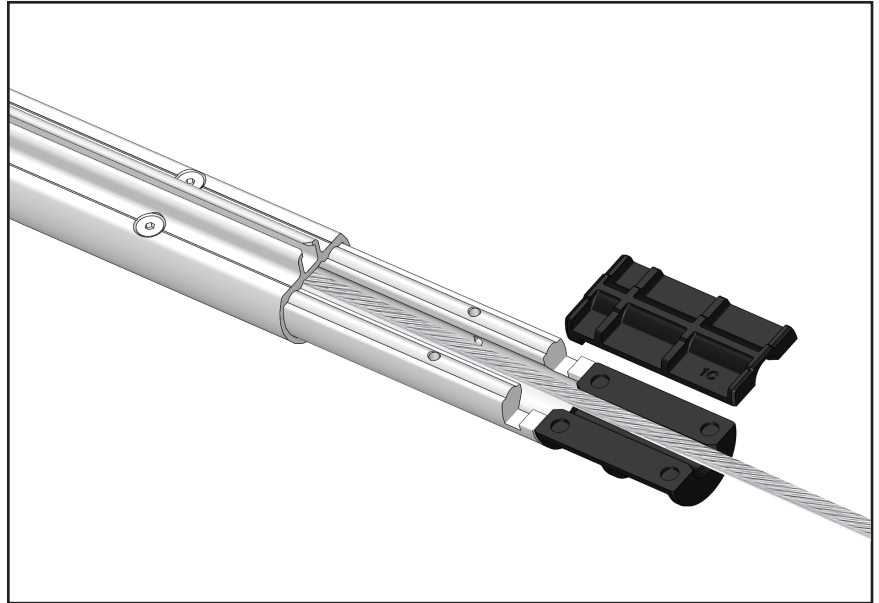

Put a drop of red Loctite® into screw holes.

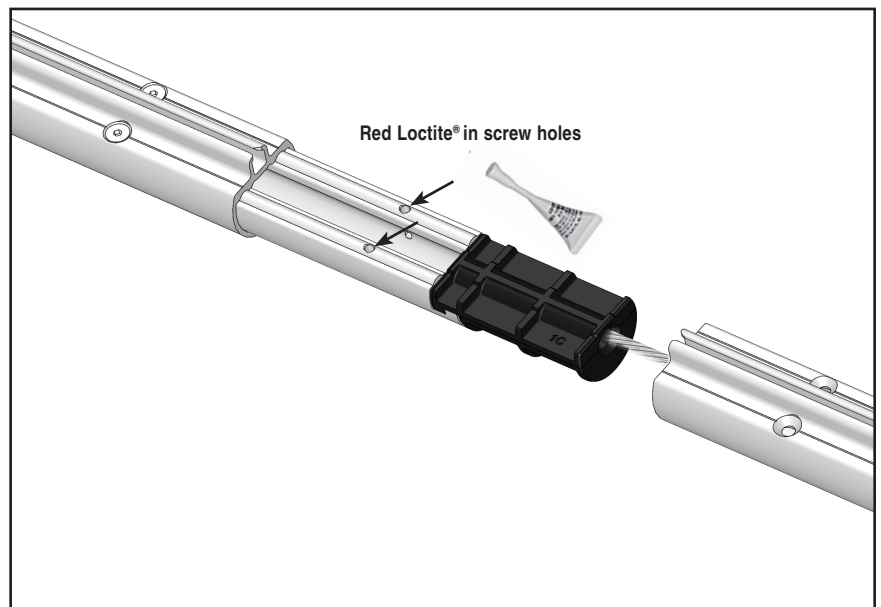

Slide foil completely over bushings and connector. Use a hex key wrench to securely tighten screws. **Continue assembly of foil system.**

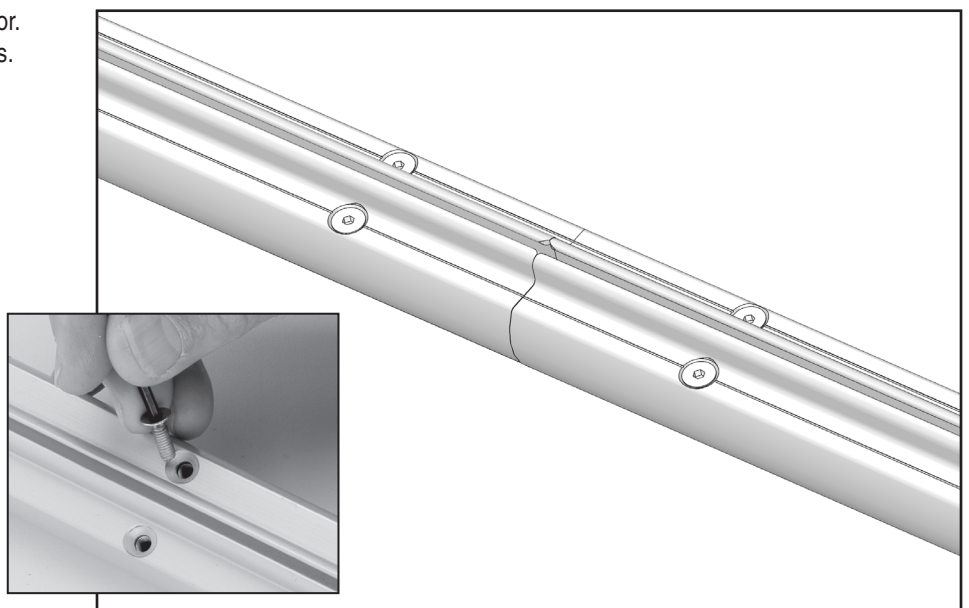

Slide halyard swivel onto foil.

IMPORTANT! Make sure up-arrow is up.

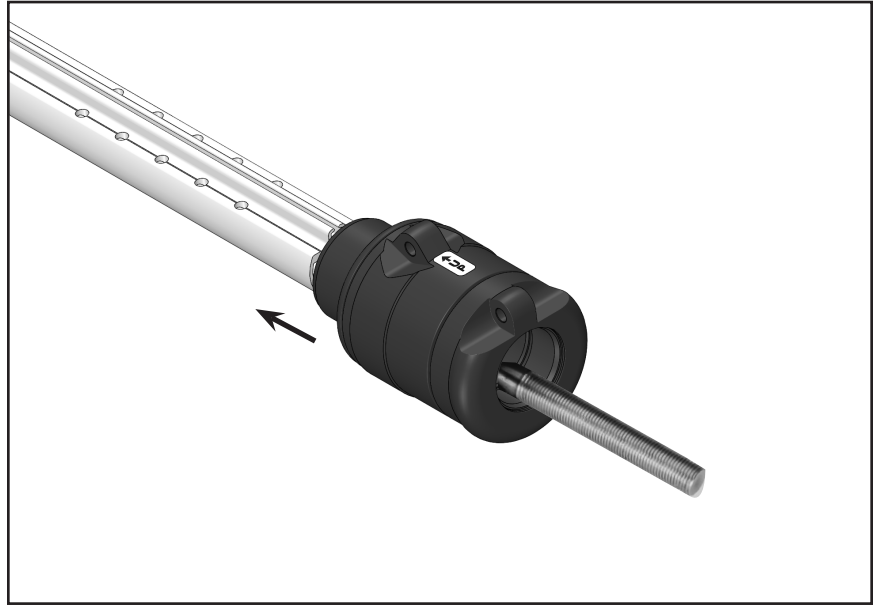

Slide drum assembly onto foil.



ROD RIGGING

Apply a few drops of red Loctite® to threads of nosepiece.

Screw main threaded stud portion onto bronze nosepiece until flats align with two cotter pin holes in terminal body.

Tip: Turn nosepiece completely into threaded stud portion. Flats will be close and may only require a small half turn to align with cotter pin holes.

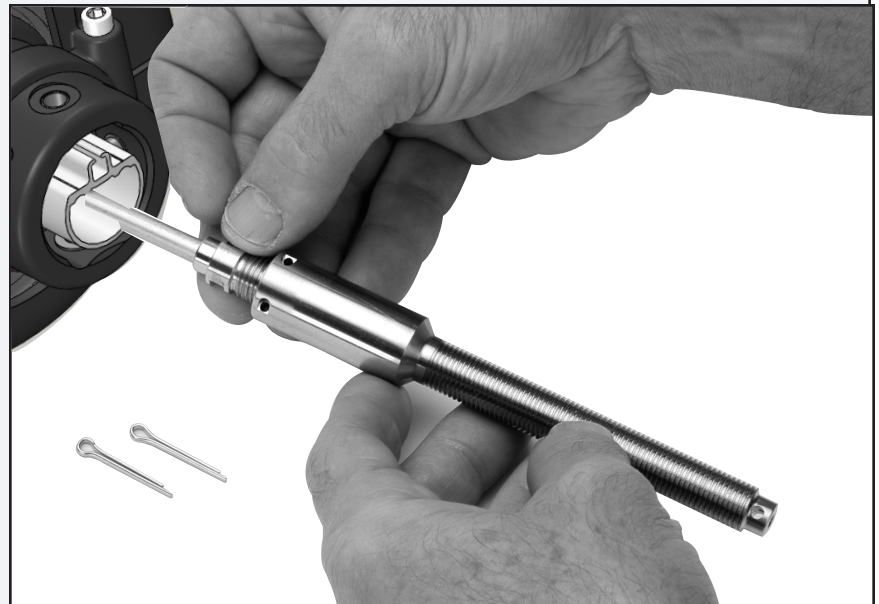

Insert two cotter pins and spread. Clean excess Loctite® from terminal body using special care to ensure that there is no red Loctite® on threaded stud.



Assemble turnbuckle and attach Harken toggle.

Note: If using Sta-Lok® or Norseman stud, you must use a washer above stud as shown below.

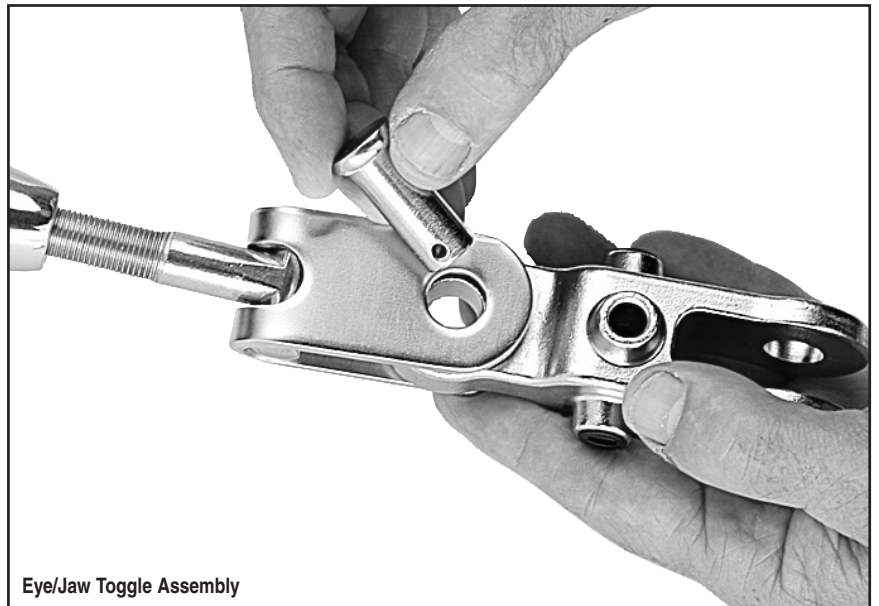
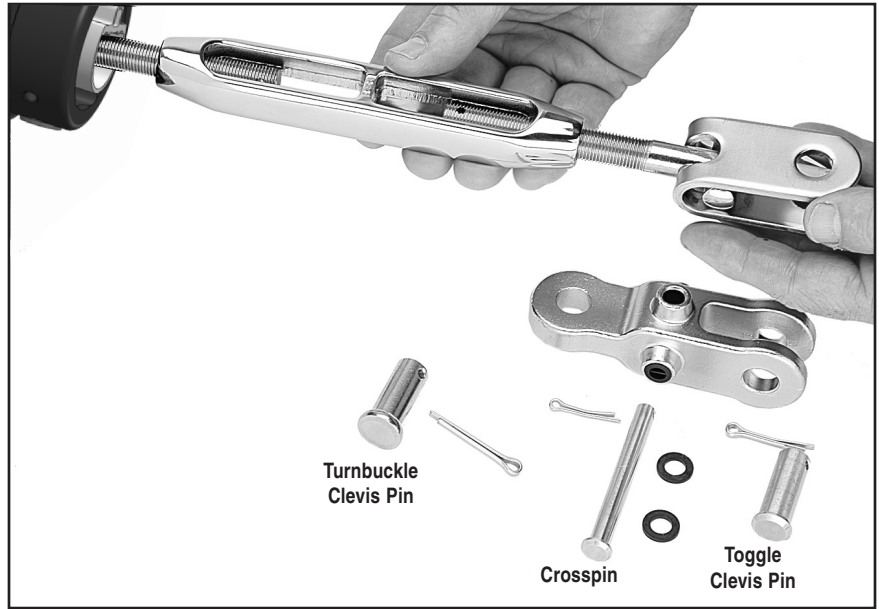
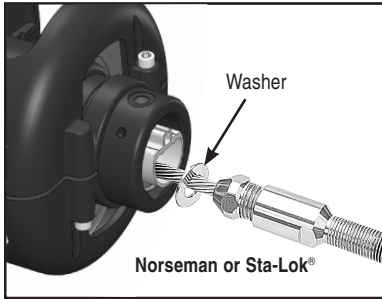

If stay length is set, use side cutters or needle-nose pliers to bend cotter pin to secure turnbuckle.



Slide lower drum assembly over turnbuckle and attach using long crosspin.

Use plastic washers provided.



WARNING! Crosspin must be 90 degrees to clevis pin that attaches unit to boat. If pins run same direction toggle will fatigue and could break suddenly.

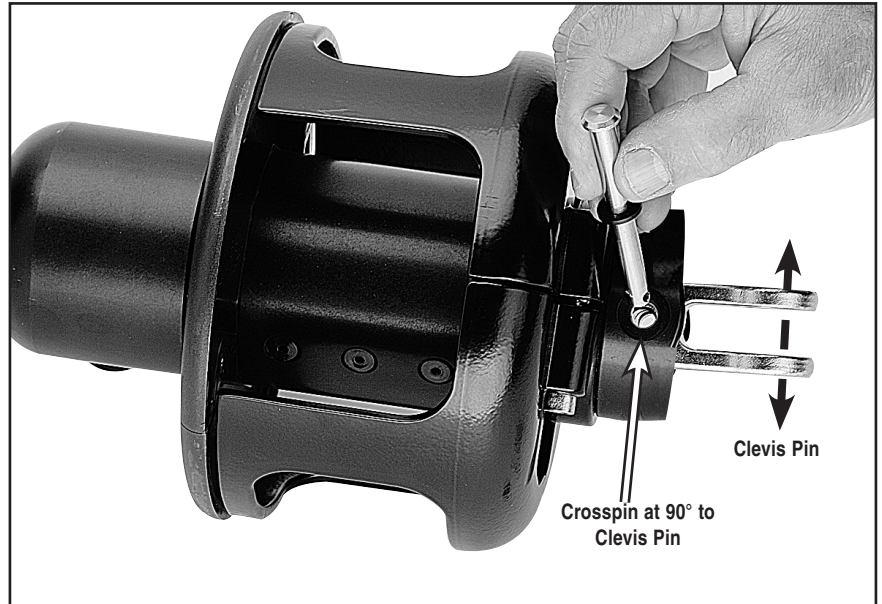

Lift foils so top of foils ride about 3/8" (10 mm) below upper terminal.



Secure using hex key. Use Tef-Gel on screws.

NOTE: You will likely adjust foil height again once system is up on the mast and turnbuckle adjusted.



Tip: To find hole position sight into the screw holes.

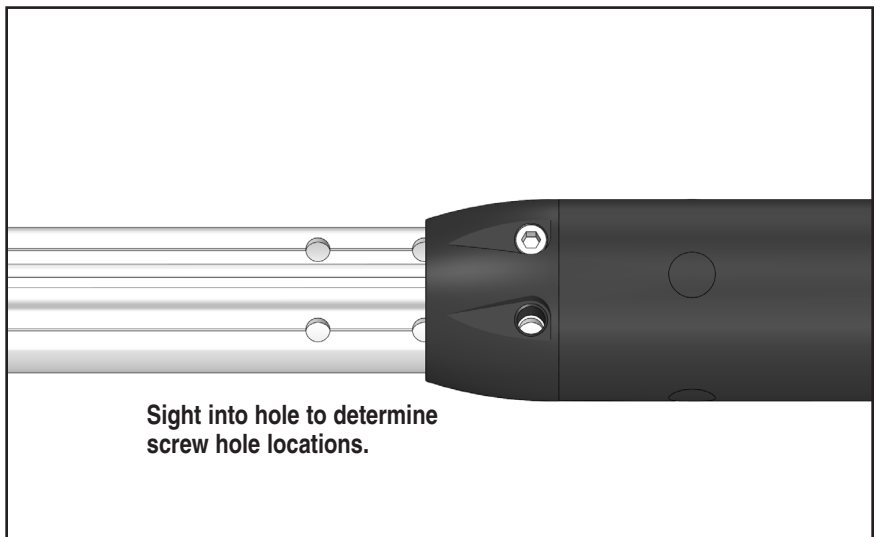

Slide halyard swivel above feeder. Place feeder tabs in position. Use a drop of 833 Blue Loctite® in screw holes. Use hex key wrench to secure.

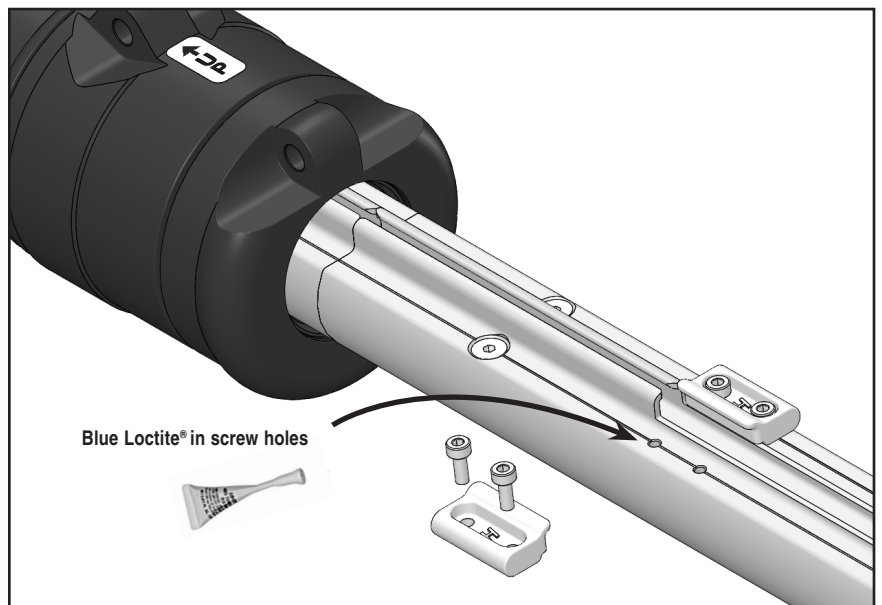

Have extra cotter pins on hand to replace used ones at base of unit and for turnbuckle. Hold foils and remove foil clamp screws. Lower foils.

Remove crosspin holding lower unit to turnbuckle. Raise drum assembly and use halyard to hold unit at about 2' (.6 m) above deck. Raise foils and secure with second halyard. **Allow room above for turnbuckle take up.**



WARNING! To avoid injury, make sure drum assembly and foils are securely lifted using a halyard before adjusting turnbuckle. Failure to do so may result in furler dropping suddenly, causing damage to the furler, or severe injury. See www.harken.com/en/general-warnings-instructions/ for additional safety information.



WARNING! Stay turnbuckle must attach to toggle. Do not attach stay to crosspin at drum assembly because crosspin and plates may fatigue and break causing an accident, damage to your vessel, personal injury, or death. See www.harken.com/en/general-warnings-instructions/ for additional safety information.

Adjust turnbuckle. Use sidecutters or needlenose pliers to bend cotter pin. Replace used cotter pins. Lower unit and install crosspin and new cotter pin.

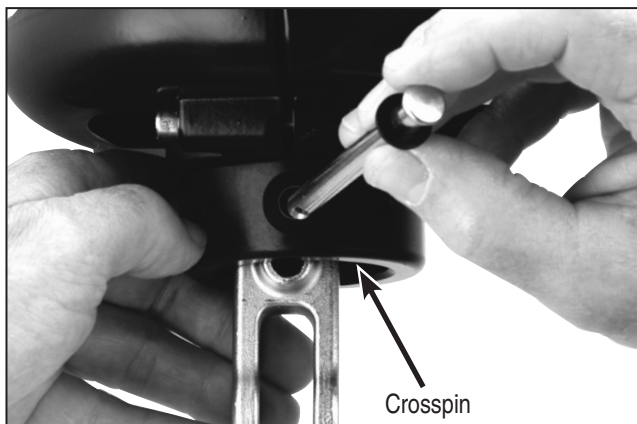

Lift foils so top is 3/8" (10 mm) below upper terminal. Use Tef-Gel on foil clamp screws when you replace them.

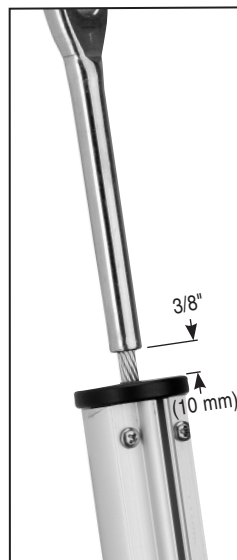

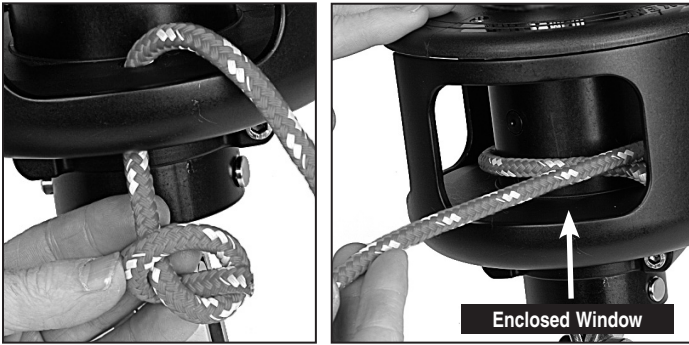

Run line through enclosed window in guard and into hole in bottom plate of spool. Tie a small overhand knot and pull it up under drum assembly.



WARNING! Lead line through enclosed window. If line is led through opening between two enclosed windows it can ride above lineguard and jam furler which can cause loss of control of boat.

Note location of sun cover. Charge system by rotating furler to wrap line on drum.

Tip: Sun cover to starboard—turn clockwise to charge. Sun cover to port—turn counter-clockwise. Tension line while charging.

Mount Lead Blocks

Furling line can be led down either side of boat. If boat is in slip, consider mounting on the side opposite the dock.

Remove four screws on stanchion blocks. Clamp blocks to stanchions. See instructions below.

Tip: Start all four screws before tightening.

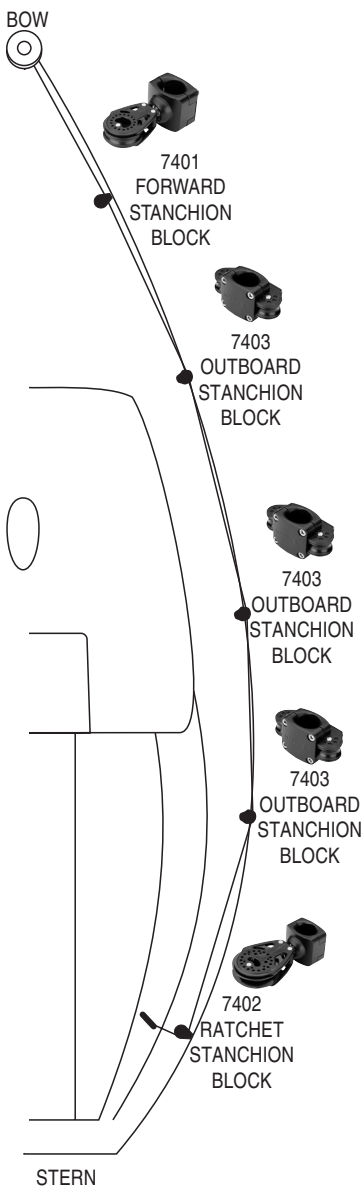

7401 Forward Stanchion Block

Position 7401 Forward Stanchion Block so line enters drum at right angles to headstay and centers vertically in opening. Install so line is inside stanchion.

Tip: Correct block position is critical to even line spooling and ease of furling.

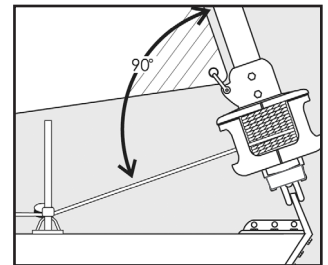

7403 Outboard Stanchion Blocks

Install 7403 Outboard Stanchion Blocks so line is outside stanchions.

Number and placement of leads depends on boat length and number/configuration of stanchions.



7402 Ratchet Stanchion Block

Mount 7402 Ratchet Stanchion Block as furthest-aft lead to prevent line overrides in drum when unfurling. Position ratchet block so line turns at least 90°.

Install so line is inside stanchion.

Tip: Lead line through block so ratchet makes clicking sound when pulling line to furl sail.

Tip: Make sure ratchet switch is in "ON" position.

If there is no clicking sound, lead line through block in opposite direction.

Lead line to Furling Line Cleat in cockpit.

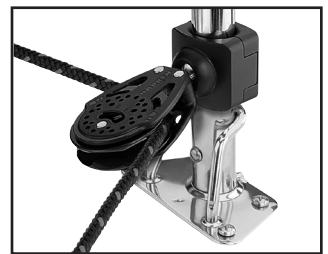

HCP168 Furling Line Cleat

Install so line is angled as shown. Use #10 (5 mm) fasteners.

Note: As furling line lead changes, make sure line doesn't chafe against line guard. Rotate line guard if necessary.

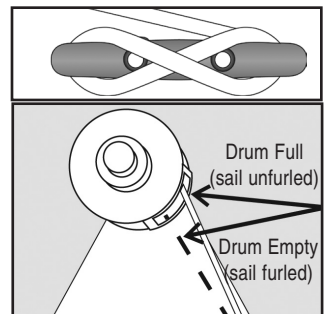

Halyard Wrap

The most serious problem with furling systems occurs when the jib halyard wraps around the headstay foil. Halyard wraps will keep you from furling or unfurling and may cause serious damage to the unit and the halyard.



WARNING! In severe cases, a halyard wrap can cause loss of control of boat and/or headstay can break suddenly. Make sure halyard is clear of top foil before using system.

If Halyard Wraps

If halyard wraps, do not force unit to turn. Attempt to open sail by carefully furling in and out a little at a time. If sail will unfurl, lower it by releasing jib halyard. Severe halyard wraps can only be cleared by a professional going aloft and freeing halyard.

If sail will not furl or unfurl, try to remove jib sheets and manually wrap sail around headstay.



WARNING! Do not go aloft on boat's halyards if there has been a halyard wrap. Do not use boat. Damage to halyard, headstay, stay terminals, or connections as a result of a halyard wrap may cause these parts to break suddenly causing mast to fall down while person is aloft. Sailing or motoring with boat after a wrap can result in the headstay breaking and mast falling down. Before using boat, have a professional rigger inspect and replace parts as necessary using following methods.

A professional rigger must carefully inspect the masthead area using a secure hoisting method. Inform rigger that there has been a halyard wrap so they can avoid an accident by relying on standing rigging or halyards. Inspection must be done while rigger is suspended from a separate crane or mast must be lowered to perform inspection. Some professionals may rig a new line through internal masthead sheaves to serve as a temporary headstay to hold mast in place. Wire, rod rigging, terminals, toggles, clevis pins, or cotter pins must be inspected and replaced if they show any signs of damage.

Prevent Halyard Wrap

To prevent wraps, the halyard must exert a slight pull to the rear. This allows the foils to turn while halyard remains stationary.



WARNING! Sail must be fitted to foil length before using to prevent halyard wraps and possible headstay loss.

1. Halyard swivel should be within top 11/2" – 6" (40 – 152 mm) of foil unless a halyard restrainer is used.
2. Halyard must pull slightly to rear (8 – 10°).
3. Halyard must be snug, but not too tight.

Tip: Test furler at dock, but if water is smooth an incorrect lead angle may not be apparent. Halyard wraps usually occur in wave action when lead angle is not correct. The 8 – 10° angle shown at right is critical.

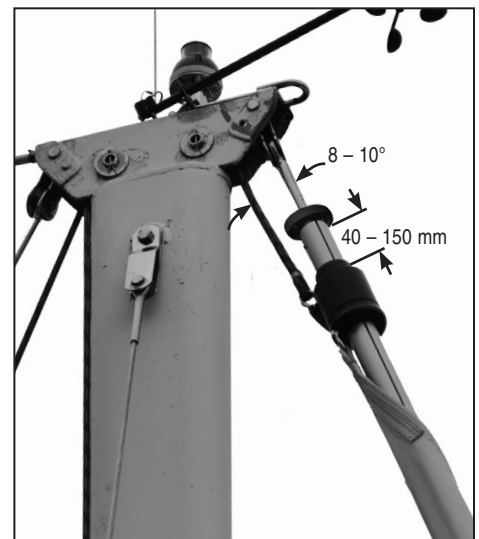

Pendants

If the sail luff is not long enough to position halyard swivel high enough to create an 8 – 10° angle as shown, you must add a pendant. Pendants should be made of plastic-coated wire and be permanently attached so sail height will be correct. Adjustable-length pendants are not acceptable, as they might not be adjusted correctly during a sail change.

1. Raise sail so sail is near the top of the foil. Do not attach tack shackle.
2. Position halyard swivel correctly near top of headstay.
3. Secure halyard.
4. Tie a piece of rope to sail tack.
5. Lead line through tack shackle on furling drum.
6. Tension sail.
7. Measure distance from tack shackle to sail tack and permanently attach pendant of this length to head of sail.
8. Repeat procedure for every jib in your sail inventory.

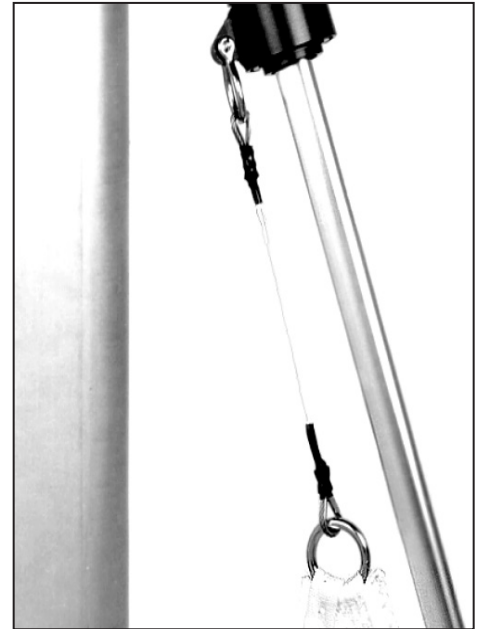

Halyard Deflector/Halyard Restrainer

To prevent wraps, jib halyard must pull slightly to rear. On most boats, halyard lead angle is acceptable if halyard swivel is raised to top of foil.

On some boats halyard sheaves are located too close to headstay and a Halyard Deflector or Halyard Restrainer must be used.

Halyard restrainers should be used only when required by masthead geometry.

Restrainers tend to limit sail luff length and may cause problems if not installed properly.

If your boat needs a Halyard Deflector, use Part No. 7301 or a Halyard Restrainer, use Harken Part No. 944.

Restrainer should be mounted as high as possible on face of mast. Position restrainer so that foils will not hit it when under load.

The restrainer should deflect halyard as little as possible or you may experience difficulty in tensioning sail luff, friction when furling, and possible damage to foils. To decrease deflection angles, shorten sail luff.

Tip: Boats used in charter service should have a halyard restrainer, regardless of masthead geometry.



Halyard Deflector

Halyard Tension

The jib halyard should be firm, but not too tight.

Tip: The luff foil system supports sail along its length so halyard tension is used only to shape sails, not to support them. Use enough halyard tension to remove some wrinkles along luff of sail. Do not tension halyard enough to cause vertical wrinkles in luff of sail. Tension to adjust position of draft in sail to suit sailing conditions. Halyard should be firm but not tight. If in doubt, release halyard tension. To protect sail, ease halyard when boat is not in use.

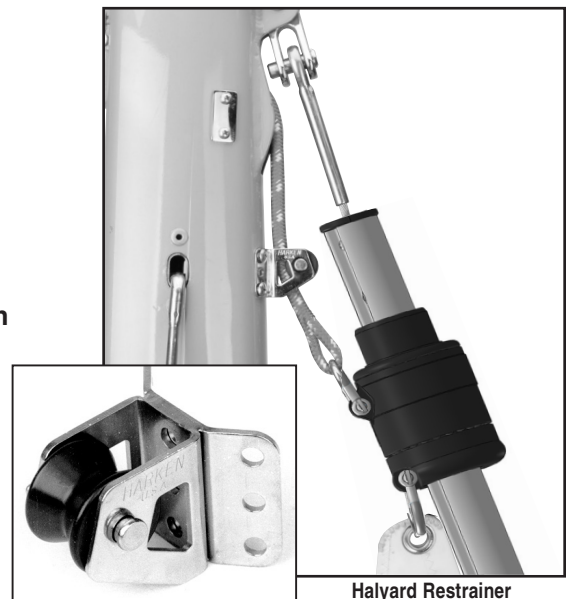

Halyard Restrainer

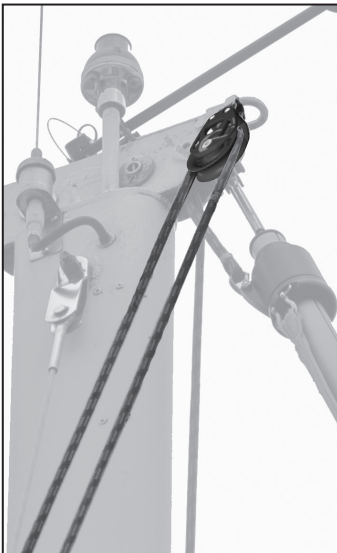

Spinnaker Halyards

Spinnaker halyards occasionally cause problems with furling.



WARNING! In severe cases, spinnaker halyards can jam furler causing loss of control of boat. Make sure halyards are clear of top of foils and halyard swivel.

On many boats it will not be possible to attach spinnaker halyard to bow pulpit or it may be "sucked" into jib when furling.

On some boats the spinnaker halyard lays across headstay and will catch on halyard swivel, foils or jib halyard. To prevent problems it may be necessary to install a masthead bail to move spinnaker halyard block forward and to one side.

Boats with external halyards may find it necessary to flip both ends of spinnaker halyard behind spreaders to prevent fouling with furling system.

Headstay Tension

A furling system will work best if headstay is tight.

A loose headstay is difficult to rotate and can cause unusual wear on foil joints.

To adjust headstay tension, remove sail and furling line from unit and follow instructions on page 20.

Tip: Before adjusting headstay tension, slack mainsheet and vang.

Backstay Adjusters

Backstay adjusters allow headstay tension to be varied to change sail shape to match conditions. They permit a very tight headstay to be eased when boat is not in use. For best performance, consider adding a backstay adjuster; either a block and tackle, a mechanical adjuster like those offered by Harken, or a hydraulic adjuster.

Remember to keep headstay tight for best performance when furling or reefing.

If your boat is fitted with an adjuster be sure that it is tensioned **before** the halyard is tensioned. If not, backstay adjuster may increase halyard tension and could damage the sail or furling system.

Racing boats often slack the headstay completely when sailing downwind. Check to be sure that foil does not jam against upper headstay terminal when backstay is released. To prevent this, it may be necessary to shorten foil slightly.





WARNING! Sail can become uncontrollable when raising in windy conditions, resulting in loss of footing. Choose wind conditions to match your experience and ability. If changing sails underway, take all safety precautions when working on the foredeck. See www.harken.com/en/general-warnings-instructions/

Raise Sail

Choose conditions with little or no wind when raising sail at the dock. Have bow of boat pointing into the wind.

- 1) **Note:** Make sure drum assembly is wrapped with line. Shackle tack of sail to drum. Install shackle so screw pin head is on same side as sun cover.
- 2) Secure genoa sheets to clew of sail using bowline knots.
- 3) Attach genoa halyard to halyard swivel.
- 4) Carefully guide sail into feeder and then into foil groove.
- 5) Attach head or pendant at head of sail to halyard swivel.
- 6) Hoist sail slowly, making sure luff tape does not jam in foil.

IMPORTANT! Forcing sail can cause luff tape to rip.

Tip: New sails are often stiff and may hang up at feeder during raising. Do not force sail when it hangs up—lower and remove twist. Sails "break in" with use and will become easier to raise.

- 7) Line up front of sail so it is parallel to foil and feeds smoothly when sail is hoisted.
- 8) Put moderate tension on the halyard and secure.
- 9) Check the top area of the furler for interference from halyards. See "Check Halyards."
- 10) Practice rolling sail in and out at the dock. See "Furl" and "Unroll Sail."
- 11) If not sailing right away, make sure sail is furled carefully. See "Secure Sail."

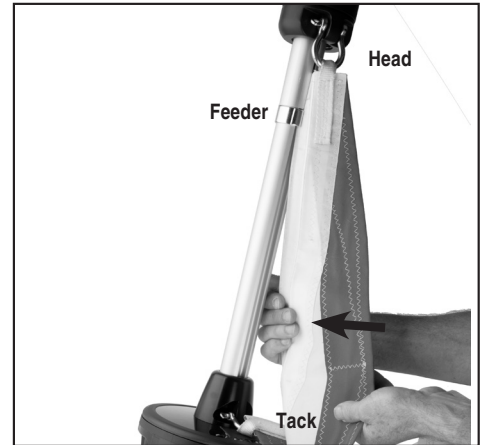

IMPORTANT! Pay careful attention to "Secure Sail" on next page. If leaving the boat, you must secure sail to prevent damage if wind increases while you are away.

Furl and Reef

To furl or reef, ease the jib sheets and pull furling line.

In very light air, it may be necessary to place some tension on jib sheet to insure a tight furl.

In a breeze, you must **completely** luff sail by **totally** slacking jib sheets before furling.

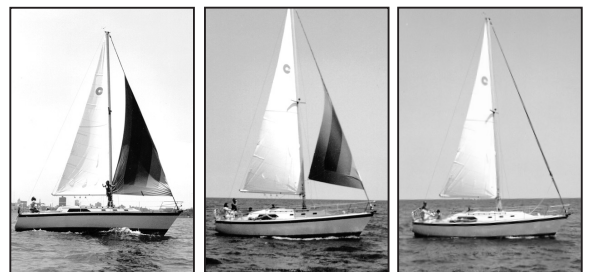

The furling line should pull readily. The amount of force required is related to amount of wind, but a Unit 0 should never require use of a winch to furl. If the sail will not furl, or if furling requires a great deal of effort, there is a problem with system. Consult the Troubleshooting Guide on Page 28. Do not use a winch to force a system to turn. If you are certain that the system is operating properly, you may use a winch to make furling easier.

Reef

A sail may be partially furled before you resume sailing. This is known as reefing.

Many sailors find it helpful to place marks on foot of sail so that they can reef to a variety of predetermined jib sizes. This allows marks to be placed on jib lead tracks or toe rail so that lead block position can be changed to correspond to reefed jib.

Sails are generally reefed to balance boat and to reduce heeling moment. Sails may also be reefed to improve visibility or to slow boat while sailing in congested areas or entering or leaving harbors.



Storm Sails

Besides a general multi-purpose genoa, use a storm sail to go offshore. If necessary add luff tape to fit foils. Add pendants to ensure that halyard swivel is properly positioned at top of headstay. See page 23. Heavy-air working jibs and storm jibs may be reefed and furled like any other sail.

Secure Sail

When furling the sail completely, make sure sheets and furling line are secured. Check amount of line on the spool compared to the furled sail before using the system.

A completely furled sail must have:

- a. Two to three wraps of jib sheet wrapped around sail.
- b. Two wraps minimum of line wound on spool.
- c. Furling line securely cleated.
- d. Jib sheets securely wrapped on winch and held in self-tailing jaws.

Furl at dock with tension on sheets to duplicate furling in high wind.

Remember that sails furled in light wind and left loosely secured can be a problem if wind increases.

IMPORTANT! Remove sail from furler if extreme winds are predicted, especially if boat is left unattended.

IMPORTANT! Check all points above—a, b, c, and d—when leaving boat to avoid damage to furler or boat.

A loosely rolled sail can catch wind in a storm. Sheets or furling lines can loosen as winds increase and allow furler to unroll. If no wraps of line are on spool, the line deadend can break the drum when the boat motors through waves.

Be sure mooring lines are not placed across furling line where they may cause chafe.

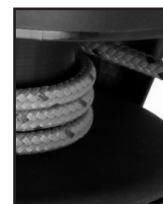
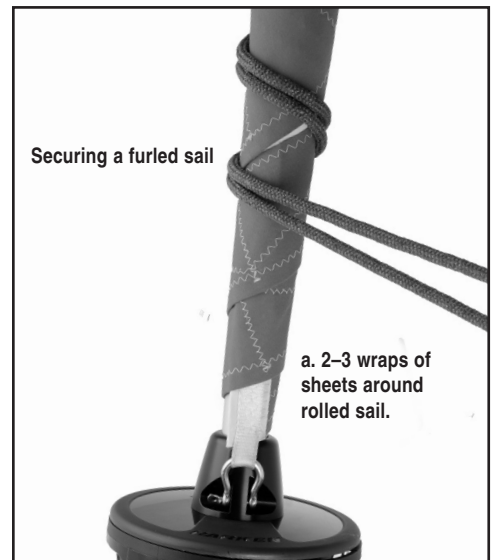

If you want to:

Add more wraps of jibsheet on furled sail.	Untie jib sheets and keep sail completely rolled. Secure with sail tie.	Turn spool to unroll a couple of wraps of line.	Retie sheets.
Add more wraps of line on spool.		Turn spool to add a couple of wraps of line.	

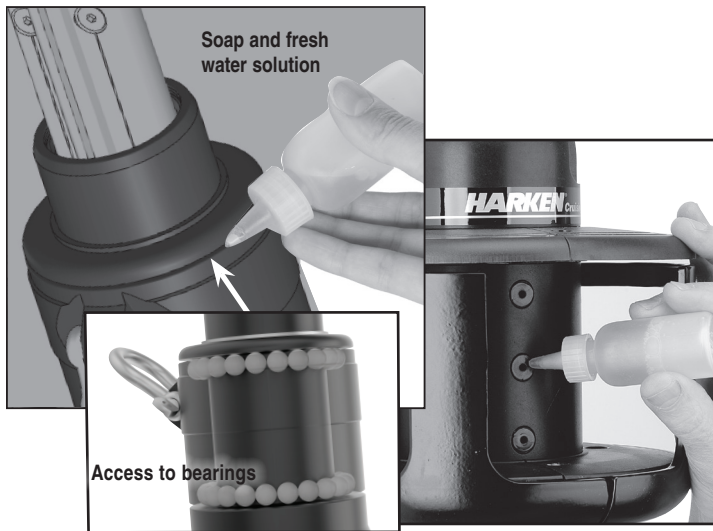

Clean

Keep unit clean. When you wash boat, flush unit with soap and fresh water. Occasionally lower sail and flush halyard swivel bearings by squirting soap and fresh water solution into space indicated at left. This will flush both upper and lower races of balls.

At least twice a year clean the unit more thoroughly by removing line (first note direction of spool) and flushing bearings with soap and fresh water.

Clean foils by washing with soap and water. To clean foil sail grooves, use the halyard and rig a downhaul to run a scrap of luff tape up and down the foil groove.



WARNING! Periodically inspect items listed below and any others as necessary. Failure to inspect can cause an accident.

Inspect

- Inspect unit for signs of chafe, wear, or damage.
- Inspect clevis and cotter pins below and inside drum assembly for signs of loosening. Check headstay tension for signs of loosening.
- Inspect swage fitting and lower toggle for signs of stress corrosion.
- Inspect Norseman or Sta-Lok® terminal or rod terminal for signs of loosening.
- Inspect all screws on unit to be sure they have not loosened.
- Inspect foil to make sure that it has not dropped into drum assembly.
- Periodically inspect wire for signs of wear or unraveling.

Replace Line

Use Harken supplied line or source a good quality line with good wear characteristics. Use 9/32" (7 mm) line with break strength exceeding 2500 lbs (1130 kg).

Storage—Mast Down

In areas where it freezes, do not store system where water can accumulate in foils. When water freezes it will rupture aluminum. Store foils under cover, with sail groove facing down or on an angle so water will run out.

Storage/Transporting

Do not store or transport system with drum assembly extending beyond mast. Remove masthead clevis pin and shift furler up so drum assembly can be strapped securely to mast. Some people remove drum assembly and halyard swivel for storage and transport.

After Storage or Transport

After storing or transporting unit, clean thoroughly including ball bearings. See instructions above.

Loosen Foil Clamp Before Slacking Backstay

In order to prevent foils from locking against upper stay terminal when backstay is released, loosen foil clamp screws and lower foil before loosening backstay.



Troubleshooting

Problem	Probable Cause	Solution
Sail will not furl or is difficult to furl.	Jib halyard is wrapping around headstay because angle between mast and halyard is too shallow	See installation instructions regarding optimal halyard angle. It may be necessary to mount a halyard restrainer on front of your mast to hold halyard to rear.
	Jib halyard is wrapping around the headstay because halyard swivel is too low.	See installation instructions regarding optimal halyard swivel height. A wire pendant may be needed at head of sail to raise halyard swivel to proper height.
	Jib halyard is too tight.	Ease jib halyard.
	Foils riding on turnbuckle.	Raise foils. See adjusting turnbuckle on page 20.
	Foils too high, binding on swage eye.	Lower foils until clear. See adjusting turnbuckle on page 20.
	Spare halyard is wrapping in sail as it furls.	Secure spare halyards away from furling headstay by flipping them behind spreaders
	Salt or dirt in bearings.	Flush bearings frequently with fresh water and detergent solution.
	Furling line tangled in drum.	Overrides are best prevented by using a 7402 ratchet block as the last furling line lead to maintain proper drag on line while unfurling.
	Stop knot catching.	Make sure knot is a single overhand and is pushed up inside drum.
	Sail full of wind.	Luff completely before furling or reefing.
	Sail flogging too much.	Release a short length of sheet, pull some furling line and repeat.
	Jib sheets are not free.	Free jib sheets.
	Foil out of drum assembly.	Reinstall foil in drum assembly and tighten clamp screws.
	No wraps of furling line on drum.	Remove sheets. Rotate stay wrapping as much furling line on drum as possible.
	Lineguard assembly has slipped down.	Tighten line guard assembly screws securely.
	Line through 7402 ratchet backwards.	Rerun line.
Halyard swivel installed upside down.	Remount swivel correctly.	
Sail will not unfurl or will not unfurl completely.	Jib halyard is wrapping around headstay because angle between mast and halyard is too shallow.	See installation instructions regarding optimal halyard angle. It may be necessary to mount a halyard restrainer on front of your mast to hold halyard to rear.
	Jib halyard is wrapping around the headstay because the halyard swivel is too low.	See installation instructions regarding optimal halyard angle.
	Foils riding on turnbuckle.	Raise foils. See adjusting turnbuckle on page 20.
	Foils too high, binding on swage eye.	Lower foils. See adjusting turnbuckle on page 20.
	Jib halyard is too tight.	Ease jib halyard.
	Spare halyard is wrapping in sail as it furls.	Secure spare halyards away from furling headstay by flipping them behind spreaders
	Salt or dirt in bearings.	Flush bearings frequently with fresh water and detergent solution.
	Furling line is not free.	Free furling line.
Sail will not furl completely.	Insufficient furling line on drum.	Remove sheets. Rotate stay, wrapping as much furling line on drum as possible.
	Too much line on drum.	Adjust amount of line on drum or change position of forward lead block to allow line to roll evenly on drum.
	Spare halyard catching in sail as it furls.	Move halyards away from furling headsail as above.
Headstay rotates in jerks or elliptically.	Insufficient tension on headstay.	Tighten headstay and/or backstay to eliminate sag in headstay.
Sail does not stay furled.	Sail not furled tightly on stay.	Maintain drag on sheets while furling.
	Furling line not secure.	Secure furling line.
Sail will not go up.	Luff tape will not go into groove.	Check luff tape for fraying. Check luff tape size.
	Sail catching at prefeeder.	Flake sail more loosely on deck.
	Dirt in groove.	Clean groove.
Sail will not raise completely or luff will not tension.	Halyard swivel is hitting end stop.	Luff of sail is too long and must be recut.
	Angle between halyard and mast is too sharp and halyard is pulling too much to the rear.	Halyard must be routed from a point higher on mast. This may require that any halyard turning blocks aloft be replaced or sail shortened.
Sail will not come down.	Halyard is wrapping on headstay.	Angle between headstay and halyard is too shallow and must be optimized per installation instructions.
	Halyard swivel off foil.	Sail luff too long or foil is too short or low and must be lengthened or raised.
Ultraviolet cover rolls up inside of sail.	Furling line is wrapped on drum in wrong direction.	Remove sheets. Pull line to remove all furling line from drum. Turn stay to rewind line on drum in opposite direction. Line guard and cowling alignment may need to be adjusted.
Line jams between guard and plastic spool plate.	Line is not led through windows.	Pull line through enclosed window.

Warranty

<https://www.harken.com/en/worldwide-limited-professional-customer-warranty/>

or call, write, email or fax Harken, Inc.,
Pewaukee, WI USA

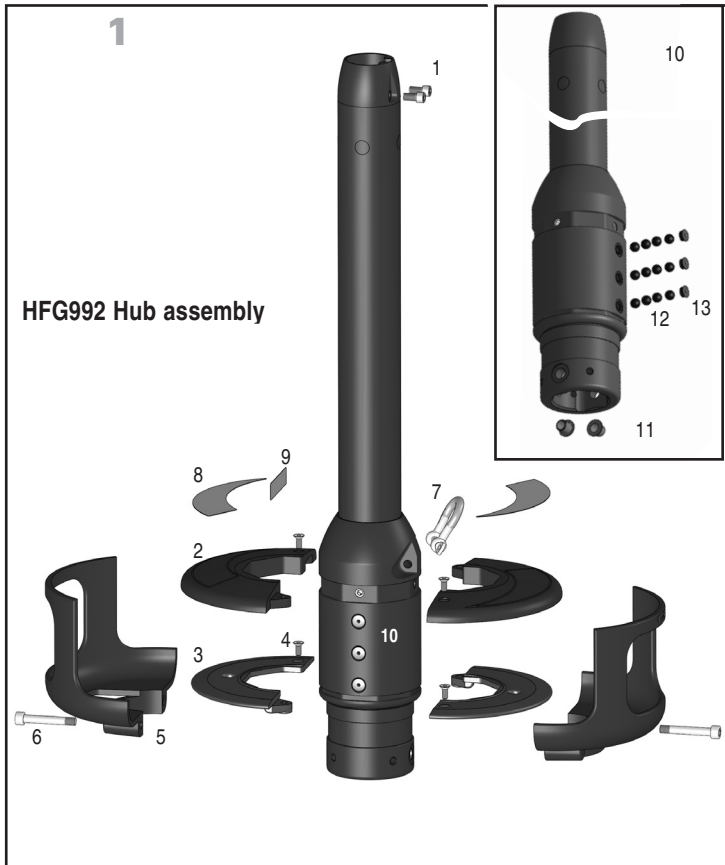

No.	Description	Order	Part No.
Hub Assembly			
1	Clamp Screw	2	H-83838
2	Cover with threaded insert	2	H-83823
3	Flange half	2	H-38818
4	Screws for flange and cover M4 x 10mm FH SHCS	4	HFS980
5	Guard half	2	H-38293.GREY
6	Guard Screw (M6 x 40mm SHCS)	2	HFS1052
7	Shackle	1	2110
8	Label for guard half	2	5355
9	Label for tack	1	5359
10	Hub	1	7510.10BASE
Reorder parts	11 IGUS® Crossspin Bushings for hub	78	HCP1744
	12 Delrin® Ball Bearings for hub	78	MP-122
	13 Ball Plugs for hub	3	H-36865

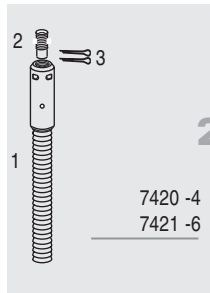

No.	Description	Order	Part No.
Rod Adapter Stud (-4) w/Nosepiece			
1	Stud (Main Body)	1	H-41707
2	Nosepiece	1	H-41708
3	Cotter Pin (3/32" x 3/4")	2	HFS181
Rod Adapter Stud (-6) w/Nosepiece			
1	Stud (Main Body)	1	H-41705
2	Nosepiece	1	H-41706
3	Cotter Pin (3/32" x 3/4")	2	HFS181

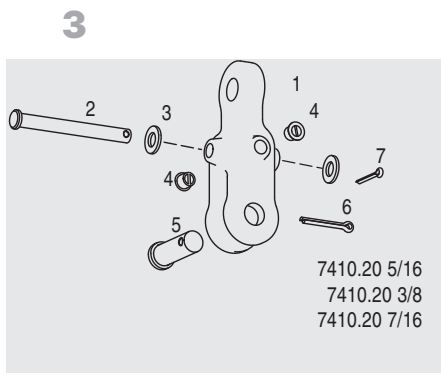

No.	Description	Order	Part No.
Eye/Jaw Toggle Reversible 5/16" (8 mm) Pin			
1	Toggle	1	H-63528
2	Crosspin (1/4" x 2-1/8")	1	H-42401
3	Nylon Washer	2	HFS1108
4	Cross Hole Plug	2	H-42050
5	Clevis Pin (5/16" x .84 Grip)	1	SP-039
6	Cotter Pin (3/32" x 3/4")	1	HFS181
7	Cotter Pin (1/8 x 3/4")	1	HFS680
Eye/Jaw Toggle Reversible 3/8" (9.5 mm) Pin			
1	Toggle	1	H-37687C
2	Crosspin (1/4" x 2-1/8")	1	H-42401
3	Nylon Washer Set	2	HFS1108
4	Cross Hole Plug Set	2	H-42050
5	Clevis Pin (3/8" x 7/8")	1	H-42400
6	Cotter Pin (3/32" x 3/4")	2	HFS181
Eye/Jaw Toggle Reversible 7/16" (11.1 mm) Pin			
1	Toggle	1	H-37686C
2	Crosspin (1/4" x 2-1/8")	1	H-42401
3	Nylon Washer Set	2	HFS1108
4	Cross Hole Plug Set	2	H-42050
5	Clevis Pin (7/16" x 1")	1	H-42399
6	Cotter Pin (3/32" x 3/4")	2	HFS181

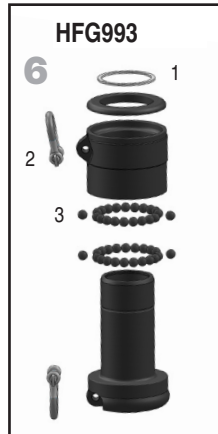
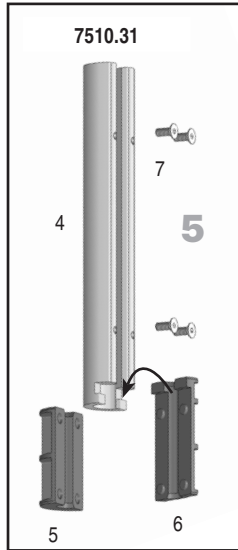
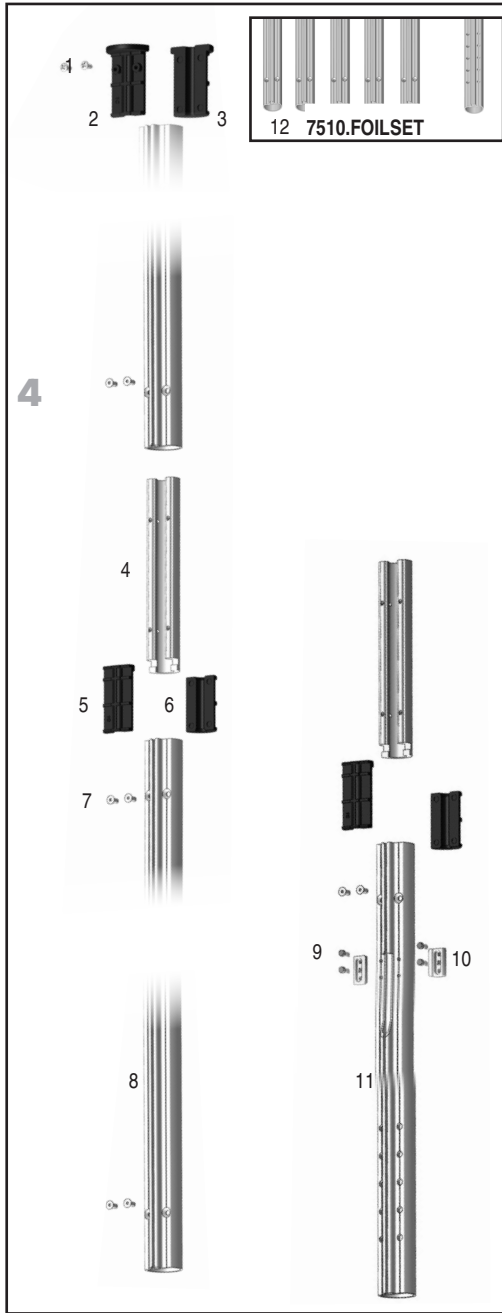

	Description	Order	Part No.
1	Trim Cap Screw 6x3/8" Tap (Qty includes 1 extra)	3	HFS1127
2	Trim Cap (bottom half)	1	H-83897
3	Trim Cap (top half)	1	H-83896
4	Connector	5	7510.31F
5	Connector Bushing (bottom, longer with hook)	5	H-83887
6	Connector Bushing (top half, shorter)	5	H-83886
7	Foil Screw M3x8mm FH SHCS	22	HFS1379
8	Foil 7' (2.13 m)	5	7510.30
9	Feeder Screw M3x8mm SHCS (Qty includes 1 extra)	5	HFS1407
10	Feeder Half	2	H-83919
11	Bottom Foil 2' (610 mm)	1	7510.33F
12	Foil set includes (5) 7510.30 and (1)7510.33F	1	7510.FOILSET

Connector w/Bushings and Foil Screws		1	7510.31
4	Connector	1	7510.31F
5	Connector Bushing (top half, shorter)	1	H-83886
6	Connector Bushing (bottom, longer w/ hook)	1	H-83887
7	Foil Screw	4	HFS1379

Halyard Swivel		1	HFG993
1	Clip/Smalley Ring	1	H-83857
2	Shackle 6 mm	2	2110
3	Torlon® Ball Bearings	44	MP-126

IMPORTANT! Ball bearings are not self contained. Remove halyard swivel to change balls or use shaving cream to hold balls in place. Use a catch box taped below.

Description	Order	Part No.
Instruction Manual	1	5389
Loctite® Red	1	HFG739
Loctite® Blue	1	833
7 mm Double Braid Polyester (55' / 16.7 m)	1	HFG594

Description	Order	Part No.
Lead Block Kit (sold separately)	1	7404
29 mm Outboard Lead Assembly	3	7403
57 mm Carbo Ratchet Assembly	1	7402
40 mm Carbo Assembly	1	7401
Horn Cleat	1	HCP168
Halyard Restrainer (sold separately)	1	944
Sheave/SS Inner Race Only	1	944ASSY
Clevis Pin (1/4" x .9" 18-8)	1	HFG467
Bracket-Small	1	HCP393
Cotter Pin (1/16" x 1/2" 18-8)	1	HFS118
Halyard Deflector (sold separately)	1	7301
Hex Keys		
5 mm	1	HFG642
3 mm	1	HCP1089
2.5 mm	1	HCP1387

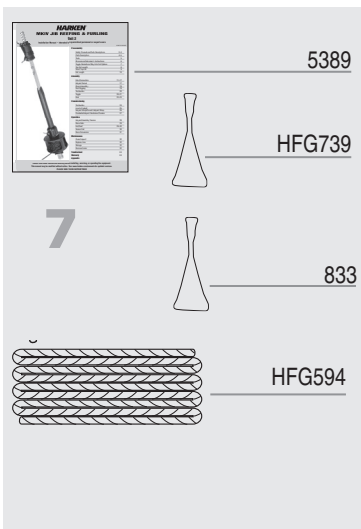

Torlon is a registered trademark of Solvay Advanced Polymers L.L.C.
Loctite is a trademark of Henkel AG & Company KGaA

HARKEN®

Unit 0 Long Link Plates With Toggle

Supplement to 5389 Ocean Furler Manual

7310.21 5/16
7310.21 3/8
7310.21 7/16

PARTS LIST

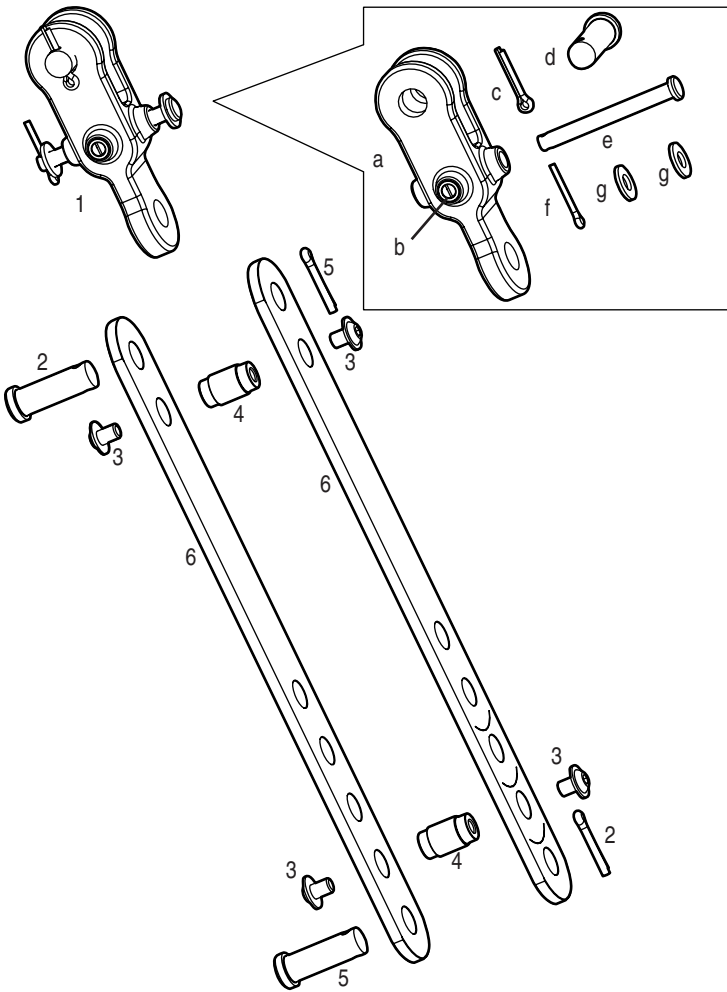

Ref	Description	7310.21 5/16	7310.21 3/8	7310.21 7/16
1	Toggle assembly	7410.20 5/16	7410.20 3/8	7410.20 7/16
a	Toggle	H-63528	H-37687C	H-37686C
b	Plug (2)*	H-42050	H-42050	H-42050
c	Cotter pin	HFS680	HFS181	HFS181
d	Clevis pin	SP-039	H-42400	H-42399
e	Cross pin	H-42401	H-42401	H-42401
f	Sm cotter pin	HFS181	HFS181	HFS181
g	Nylon washer (2)	HFS1108	HFS1108	HFS1108
2	Cotter pin (2)	HFS680	HFS680	HFS680
3	Flanged buttonhd (4)	H-91922	H-91922	H-91922
4	Spacer (2)	H-92593	H-92594	H-92595
5	Clevis Pin (2)	H-93402	H-42400	H-42399
6	Strap (2)	H-92585	H-92587	H-92589
	Blue Loctite®	833	833	833

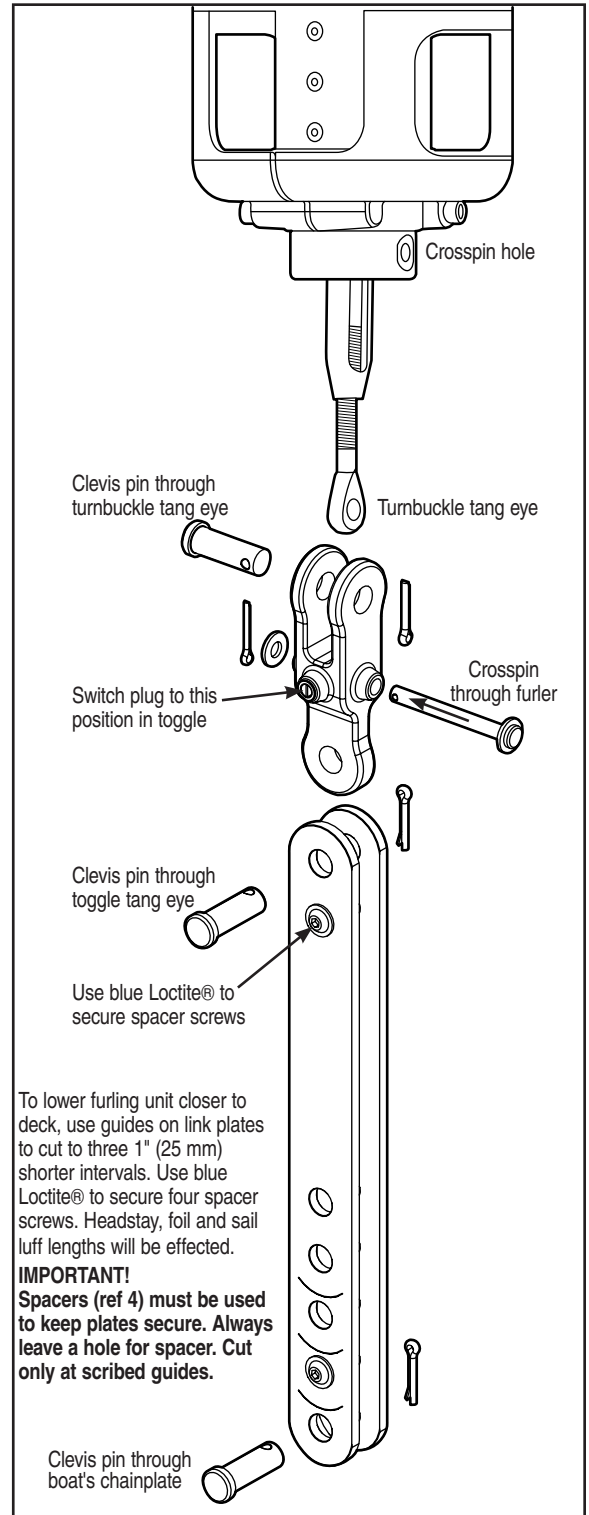

To lower furling unit closer to deck, use guides on link plates to cut to three 1" (25 mm) shorter intervals. Use blue Loctite® to secure four spacer screws. Headstay, foil and sail luff lengths will be effected.

IMPORTANT!
Spacers (ref 4) must be used to keep plates secure. Always leave a hole for spacer. Cut only at scribed guides.

Luff Length

Note offsets above and below sail.

A shorter luff may be required if a halyard restrainer is necessary (page 23) or a toggle or long toggle assembly is used to raise drum.

If luff of sail is not long enough to put halyard swivel near top of headstay foil, a pendant must be added (see page 23).

Tack Setback

Note setback for tack shackle and cut the sail accordingly. Feeder height depends upon up/down foil position in lower unit.

Luff Tape Size -6 (5 mm or 6/32")

J – Finished luff tape size: 5.5 mm (0.215")

K – Luff rope size: 4.8 mm (6/32", 3/16")

L – Max Ø in sail groove: 6.1 mm (0.24")

M – Gap in sail groove: 2.4 mm (0.096")

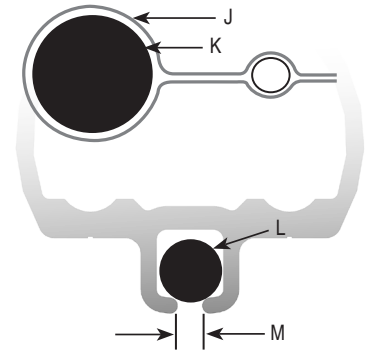

Luff Tape Length

Note feeder height and extend bottom of luff tape downward so it is below feeder. This will prevent luff tape from catching in feeder as sail is lowered.

Tack and Head Shackles

Make sure tack and head shackles fit sail rings. Minimum inside dimensions of standard head and tack shackles are:

(A) 1-1/16" (27 mm)

(B) 1/2" (13 mm)

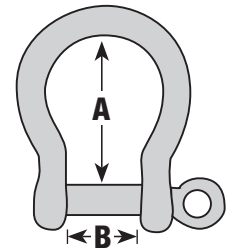

Sun cover

Sun covers may be installed on either side of the sail. Be sure to match other sails in the customer's inventory.

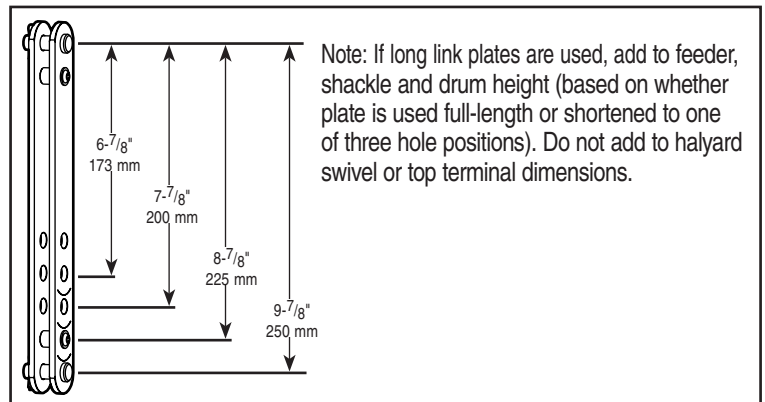
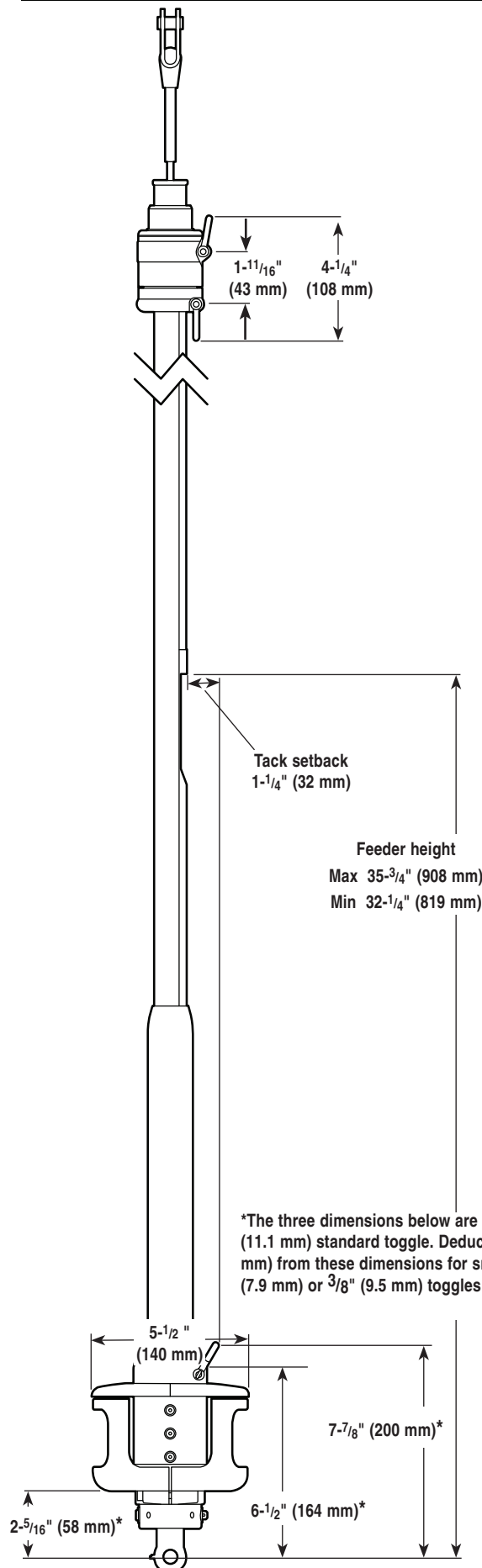

Note: If long link plates are used, add to feeder, shackle and drum height (based on whether plate is used full-length or shortened to one of three hole positions). Do not add to halyard swivel or top terminal dimensions.

Use dimensions of Harken toggle below to build stay to correct length.

Tip: Turnbuckles should be 1/2 to 2/3 open to allow shortening for new wire stretch and for fine-tuning mast rake.

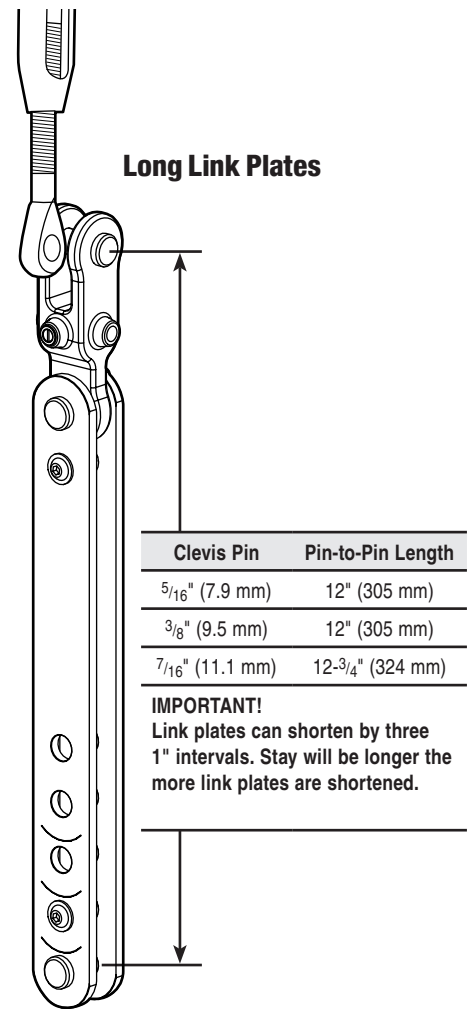
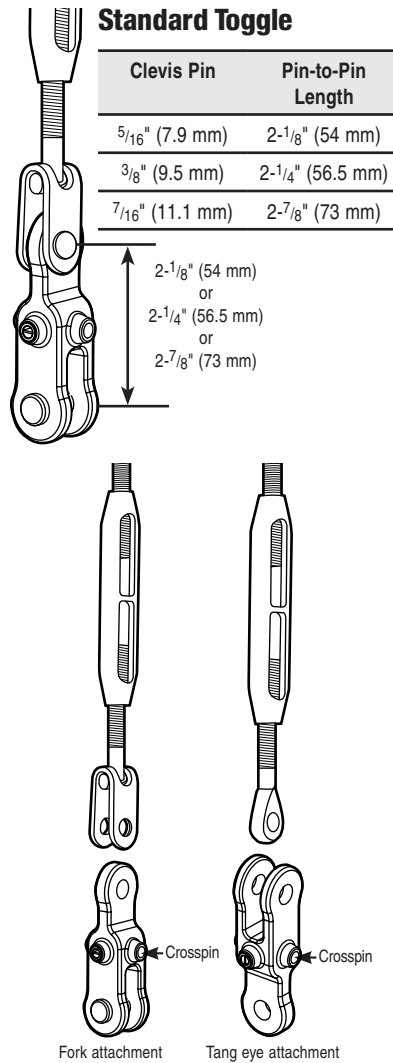
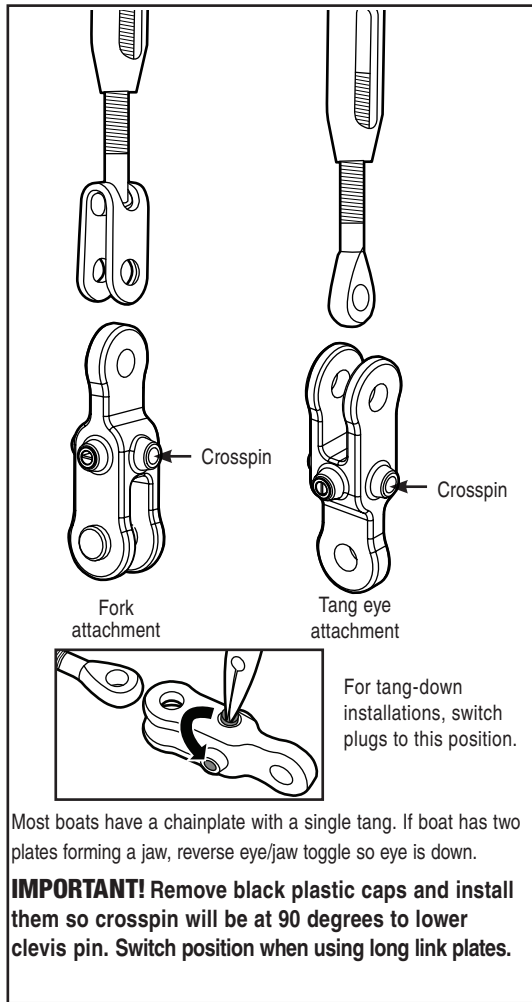

Options for Snaking Stay into Foils

1. Swage stud at end of wire.
2. Open end of wire and install Norseman or Sta-Lok® stud after foil is assembled.
3. Rod adapter nosepiece for Harken rod adapter stud: Threaded nosepiece must have a positive lock as well as adhesive. Use Harken stud with cotter pins (see page 19).

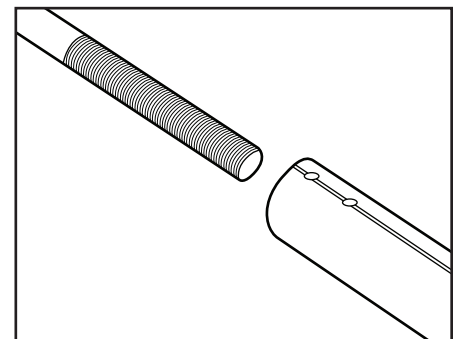

WARNING! Using a threaded nosepiece with only adhesive at the upper rod eye terminal may result in headstay system failure. Make sure there is a mechanical lock.

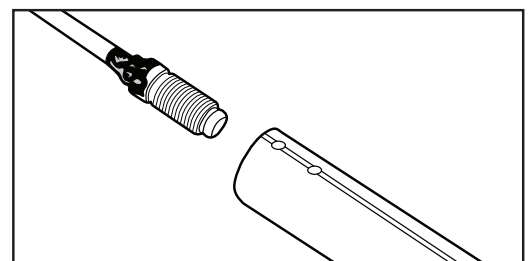
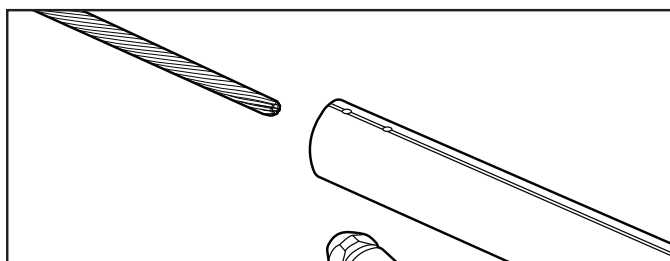

Supplement to 5389 Ocean Furler Manual - Top foil length - page 8

Measure A and add to this chart and "length chart" below		
	Inches	mm
A		
B	.4*	10*
E	24.0	610
F	13.9	354
G		
Total A+B+E+F+G		

Make sure upper measurement points of A and pin-to-pin are the same.

Alternate Measurement Point

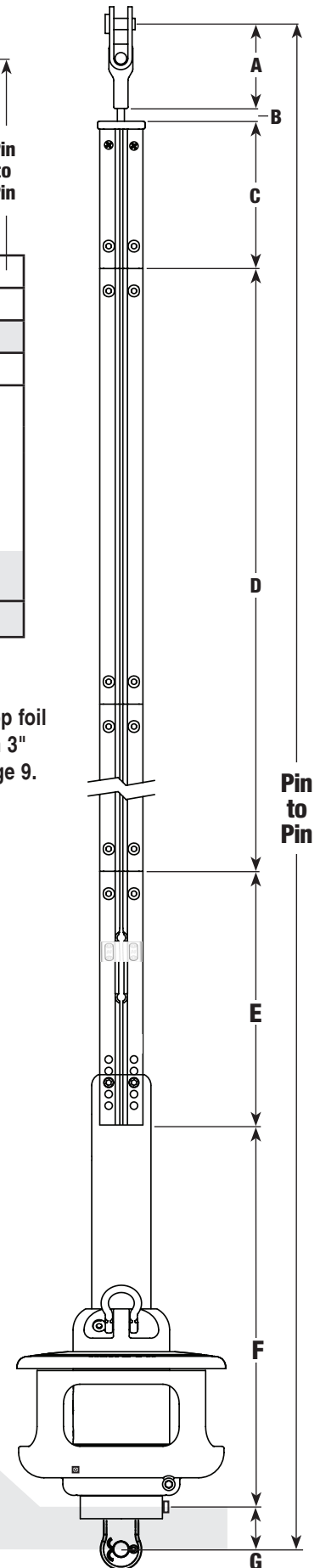
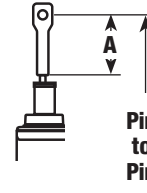

*Add 1" (25 mm) if using a 7301 halyard deflector. See page 10.

UNIT 0

1	Pin-to-Pin Length	
2	Subtract ABEFG	-
3	Result (Pin-to-Pin - ABEFG)	
4	Subtract D	-
To find "D" pick number from chart below that is closest to, but not greater than total from step 3.		
Inches		mm
3 X 84 = 252		3 x 2133.6 = 6400.8
4 X 84 = 336		4 x 2133.6 = 8534.4
5 X 84 = 420		5 x 2133.6 = 10668
6 X 84 = 504		6 x 2133.6 = 12801.6
Example—If result from Step 3 is:		
500 inches "D" = 420 inches 12,000 mm "D" = 10,668 mm		
5	Result (C) Top Foil Length	

IMPORTANT! If top foil length is less than 3" (76 mm), go to page 9.

Length Check

After completing worksheet above fill in A, C, D and G below. Add "A" through "G" to confirm total equals your pin-to-pin measurement.

Pin-to-Pin Length Worksheet			
Dimensions	Inches	mm	
A Center of Pin to Bottom of Terminal			
B Bottom of Terminal to Top of Foil	.4	10	
C Top Foil Length			
D Number of Foils _____ x 84" (2133.6 mm)			
E Bottom Foil	24.0	610	
F Bottom of Foil to Crosspin	13.9	354	
G Crosspin to Clevis Pin			
Pin-to-Pin Length			

G Toggle Distance from Lower Clevis Pin to Crosspin Hole					
Toggle Part No.	Type	Clevis Pin		G Distance	
7410.20 5/16	Eye/Jaw	5/16"	7.9 mm	1.1"	27 mm
7410.20 3/8	Eye/Jaw	3/8"	9.5 mm	1.3"	33 mm
7410.20 7/16	Eye/Jaw	7/16"	11.1 mm	1.4"	36 mm
7310.21 5/16	Long link plates with toggle	5/16"	7.9 mm	10.9"	277 mm
7310.21 3/8	Long link plates with toggle	3/8"	9.5 mm	11"	280 mm
7310.21 7/16	Long link plates with toggle	7/16"	11.1 mm	11.3"	287 mm
Note: If long link plates are shortened, dimension must be changed or foil will be too short. Measure distance from crosspin down to where clevis pin attaches toggle to boat and use this dimension in G above.					

Assemble turnbuckle and attach Harken toggle.

Note: If using Sta-Lok® or Norseman® stud, you must use a washer above stud as shown below.

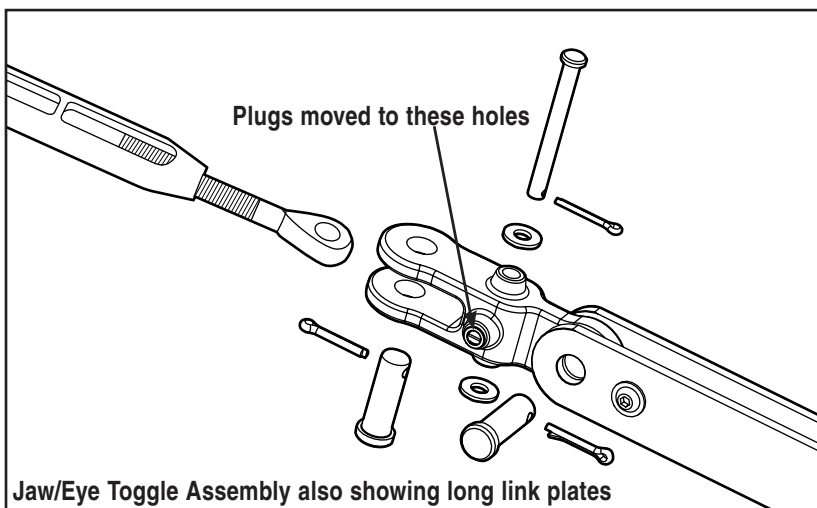
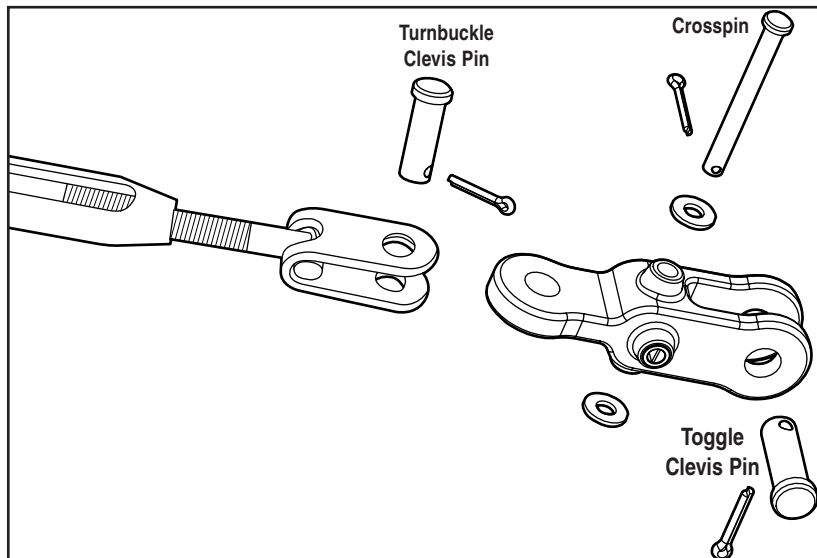
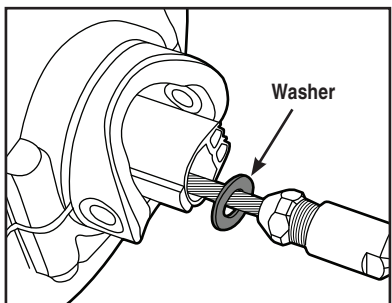

HARKEN[®]

Country of Manufacture - USA

Manufacturer - Harken, Inc.

N15W24983 Bluemound Rd., Pewaukee, WI 53072-4974 USA

+1 262 691-3320

www.harken.com

www.harken.com/en/contact-us/

5389C 03/2026