

HARKEN®

INSTRUCTION SHEET

Halyard Restrainers

944/945/1113

N15W24983 Bluemound Rd, Pewaukee, WI 53072-4974

Telephone: (262) 691-3320 • Fax: (262) 701-5780

Web: www.harken.com • Email: harken@harken.com



Strictly follow all instructions to avoid an accident, damage to your vessel, personal injury or death. See www.harken.com/manuals for additional safety information.

To be used if angle between halyard and headstay is less than 7°. This is common on masts where halyard sheave is very close to headstay.

USE ONLY IF NECESSARY

If halyard angle is greater than 7° and halyard is still wrapping, a halyard restrainer may not be necessary. Halyard swivel must be near top of foils and headstay must be tight. This will prevent halyard wraps in most cases. Consult furling instruction manual.

Tools and Supplies

Method	Rivet	Tap U.S.	Tap Metric
Fasteners (not included)	(6) 3/16" SS Rivets	(6) 10-32 x 3/8" SS Machine Screw RH	(6) 5 x .80 x 10 mm SS Machine Screw TH
Drill Ø	13/64" (5 mm)	5/32"	4.2 mm
Tap Size	—	10-32	5 x .80 mm

Drill • Pliers • Heavy-duty rivet gun or screwdriver

Mounting Instructions

1. Hoist tallest sail that will be used.

If mast is down, angle headstay out to stemhead chainplate ("J" dimension). Measure luff length of tallest sail and position restrainer as directed below.

Installations aloft should be performed by rigging professionals only.

2. Remove sheave from restrainer, install wire and re-fasten sheave. **Note:** Be careful to not lose stainless steel sleeve when removing sheave. Make sure forward side of restrainer is parallel to headstay.

Do not install upside down. See drawing on reverse side. Bend cotter pin so clevis pin will not fall out.

3. Position restrainer on mast so halyard is at a 7 to 10° angle to headstay. See drawing on reverse side.

If necessary have a sailmaker cut down top of sail to create a 7 to 10° angle between halyard and headstay.

With restrainer installed, halyard swivel will ride lower than installations without restrainers. This is necessary to achieve correct halyard angle.



4. Mark position of holes and drill.



WARNING! Drilling or fastening into mast may snag halyards holding the installer aloft seriously reducing strength. Limit drill depth and avoid fasteners protruding into mast where they may interfere with halyards.

5. Ease halyard. Install fasteners in all six holes.

6. Tension halyard and test furling system. Do not over-tension halyard or system will be difficult to furl.

7. If a shorter-hoist sail is used, install a pendant between sail and halyard swivel so halyard swivel is at same height as tallest sail.

This End Up

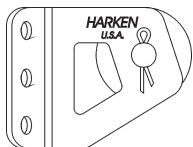

Install so
"HARKEN"
is up.

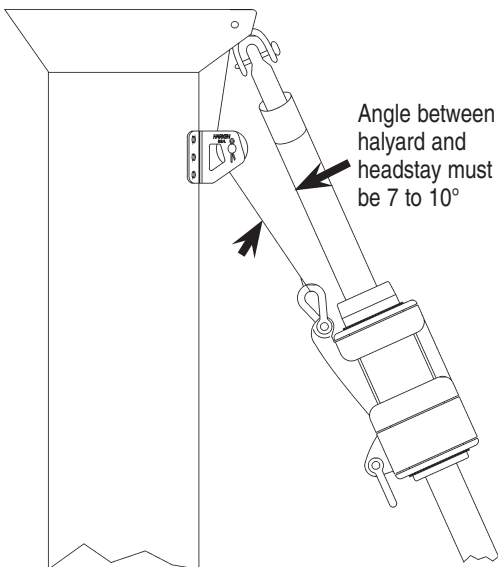

Maintenance

Harken equipment requires minimal maintenance, but some is required to give the best service and to comply with Harken's limited warranty.

It is important to keep equipment clean by frequently flushing with fresh water.

In corrosive atmospheres, stainless parts may show discoloration around holes, rivets and screws. This is not serious and may be removed with a fine abrasive.

With the exception of winches, do not use grease unless specifically recommended in the instruction sheets.

Warranty

For additional safety, maintenance and warranty information see www.harken.com/manuals or the Harken® catalog.