



HARKEN[®]

**R27 Rail
Instruction Manual**



Read the manual carefully before using, installing and servicing the equipment.

Translation of the
original instructions

UR27R 11/2024



About this manual	page	4
Safety information	page	5
The rail	page	6
Components	page	6
Prerequisites and limitations	page	8
Design	page	11
Preliminary information	page	11
Installing the rail	page	12
Colored rail	page	13
Bent rail	page	13
Thermal expansion	page	14
Installation	page	14
Rail installation guidelines	page	15
Endstop assembly instructions	page	16
Preliminary and periodic checks	page	18
Annual check	page	20
Packaging, storage, transportation	page	20
Maintenance	page	20
Certifications	page	20
Labeling	page	21
Warranty	page	21
Certificate of Compliance	page	22
Records	page	23
Correct installation form	page	23
Acceptance report	page	24
Example of license plate	page	25
Maintenance-Inspection register	page	26

ABOUT THIS MANUAL

ABOUT THIS MANUAL

Before installing or using the Harken R27 rail, read the instructions contained in this manual thoroughly.

This instruction manual is an integral part of the product, and it supplies all the necessary information for its correct installation, safe use, and maintenance.

If any portion of this manual is not understood, please contact Harken's authorized dealer/installer. Harken shall not be liable for damages, injuries or death caused by a non-compliance to the safety and other instructions contained in this manual.

This manual is intended for qualified installers and users. The installer is responsible for integrating the supplied information according to current legislations.

This manual, including the information supplied by the installer, must be stored by the client and made available to the user. It must be stored in a suitable place, near the fail arrest system entrance, and it must be made available to the user.

This manual may be modified without notice. See <http://www.harken.com> for updated versions.



WARNING!

It is essential for the safety of the user that if the product is re-sold outside the original country of destination the reseller shall provide instructions for use, maintenance, periodic examination, and repair in the language of the country in which the product is to be used.

SAFETY INFORMATION

- Harken R27 rail must be installed by personnel authorized by Harken, a Harken dealer, or qualified personnel trained on the installation of the Harken R27 rail, and on personal protective equipment (PPE).
- The rail installer must verify the structure where the rail will be installed is suitable to fasten the device and to support the loads for which the rail has been certified.
- The type of structure anchor/fixing must be defined by a qualified professional.
- The procedure to fasten the rail to the base must be documented in suitable reports and made available for future consultation.
- Each rail has maximum load limits, which mostly depend on the structure where it is installed and on the distance between the anchor/fixing; those limits must not be exceeded.
- The R27 rail must be used solely with Harken trolleys (IN9565, IN9565.CLEAR, IN9608, IN9608.CLEAR, IN9606, IN9606.CLEAR, IN10614, IN10614.CLEAR, IN10615, IN10615.CLEAR, IN10567, IN10567.CLEAR, IN158, IN158.CLEAR, INCAR1-CURVE, INCAR1-CURVE (BLACK), INCAR2-CURVE, INCAR2-CURVE (BLACK)), while wearing suitable PPE compliant with the laws in force on workplace safety.
- Before using the rail, check its path and the falling hazards, evaluating the minimum fall clearance and choosing the PPE with shock absorber deployment most suitable to the type of hazard.
- Before each use, check the system for any trace of wear, corrosion, deformation, or loose connections. When in doubt, or if a rail seems unsafe, it must be checked by Harken, Harken dealer's authorized personnel, or by qualified personnel.
- All operators using the rail must observe the instructions for uses, and especially the number of operators it can support at the same time.
- In case of extreme weather events, do not use the rail.
- In case of fire or if the rail has been struck by lightning, stop using it, report the issue to Harken Approved Installer and/or Harken to arrange a detailed inspection by Approved and Qualified Personnel.
- Do not modify the rail in any way unless previously authorized in writing by Harken, Harken dealer's authorized personnel, or by qualified personnel.
- Harken shall not be liable for injuries or damages resulting from improper use of the rail.
- The system must be used only by physically and psychologically healthy personnel. Cardiac and circulatory problems, taking medications, alcohol, and drugs could compromise the safety of the user when working at height.
- Before installing and using the system, it is mandatory to organize the safety plan in case emergencies occur during work.

THE RAIL

R27 RAIL

The anodized aluminium R27 rail (IN1643, IN1643.CLEAR, IN1650, IN1650.CLEAR) must be fastened to a supporting structure using suitable screws. A low friction trolley (IN9565, IN9565.CLEAR, IN9608, IN9608.CLEAR, IN9606, IN9606.CLEAR, IN10614, IN10614.CLEAR, IN10615, IN10615.CLEAR, IN10567, IN10567.CLEAR, IN158, IN158.CLEAR, INCAR1-CURVE, INCAR1-CURVE (BLACK), INCAR2-CURVE, INCAR2-CURVE (BLACK)), is to be installed to the rail, providing a compliant EN795:2012 Type B mobile anchorage point. This assembly includes a rigid fall arrest system designed to be used and installed in horizontal position ($\pm 5^\circ$) with floor, wall, and ceiling mount. By installing and using this system correctly, the risk of the operators falling while working at height can be eliminated or significantly reduced.

Furthermore, the R27 rail can be used as a rope access anchorage system to provide a safe anchorage for twin rope working (rope access & work positioning), with good anchor mobility under load.

COMPONENTS

The R27 rail must be used with the following components to constitute the Harken Access Rail system:

Trolleys

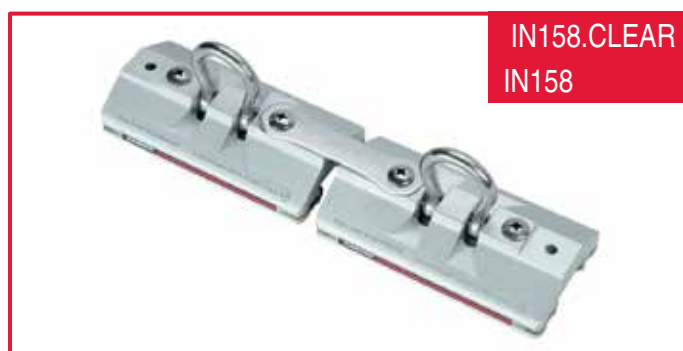

18 types of trolleys are available (single trolley for fall arrest system and double trolley for human suspension).

The part number without .CLEAR refers to the black hard-coat anodized version of the trolley.

Rails



Extruded anodized aluminium rail available with different length. For more details see the catalog. The rail can also be supplied bent.

The part number without .CLEAR refers to the black hard-coat anodized version of the rail.

Endstops



Connectors



PREREQUISITES AND LIMITATIONS

PREREQUISITES AND LIMITATIONS

The R27 rail has been designed to support any accidental operator fall. To guarantee its correct operation and maintain mechanical integrity in case of fall, each user must wear the PPE recommended by workplace safety regulations.

All PPE must be certified and marked according to the relevant national regulations. By using the PPE, in case of a fall, the force transmitted to the operator (and consequently to the trolley sliding on the rail) will be no greater than a maximum **6 kN**. Personal fall arrest systems include, but are not limited to, an energy-absorbing mechanism, lanyard, and a full body harness to limit the maximum arresting force to 6 kN.

Personal fall arrest systems used with this equipment must meet controlling regulations for the country of use.

Fall clearance - There must be sufficient clearance below the user to arrest a fall before the user strikes the ground or other obstruction. Sufficient clearance consists of the stopping distance plus the free space of 1 m under the feet of the user. See appropriate documentation published by regulatory authority.

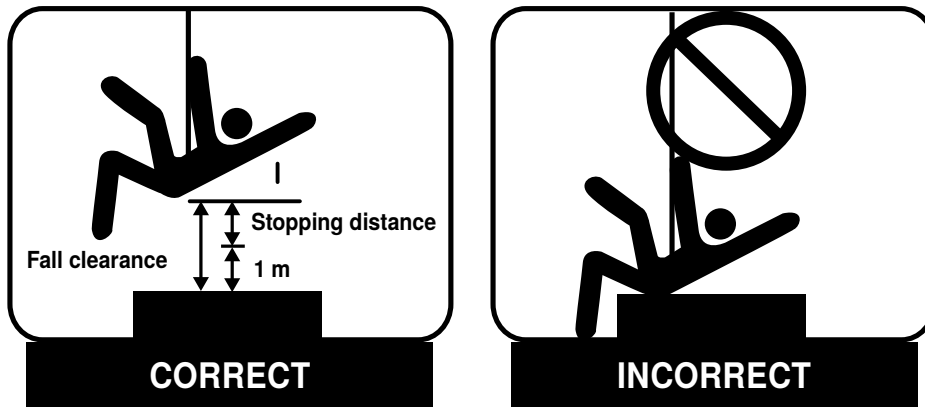

WARNING!

It is essential for safety to verify the fall clearance required beneath the user before each occasion of use, so that in the case of a fall there will be no collision with the ground or other obstacle in the fall path.



WARNING!

The maximum value of deflection of the trolley and displacement of the anchor point that can occur in service is 20 mm. Consider this value to evaluate the system fall clearance correctly.



WARNING!

The use of non-compliant PPE can result in severe injuries, including death.



WARNING!

To avoid personal injury, the R27 trolley and rail must be used with a full body safety harness (EN361 approved) which is the only acceptable body holding device that can be used in a fall arrest system. A full body harness can also be used with a working harness or chair (EN361 and/or EN813 approved). It must also be used with a fall arrest device (EN353/2 approved) and an energy absorber (EN355 approved) that also meets fall protection standards as required by the local regulating authority for the country of use. Connectors (hooks, carabiners, and D-rings EN362 approved) must be capable of supporting at least 22 kN (5,000 lb).



WARNING!

Consult Harken when using this equipment in combination with components or subsystems other than those described in this manual. Altering or intentionally misusing this equipment may cause the system to fail which can cause a fall, which could result in severe injury or death.

Before using the Access Rail system verify all people and objects are clear of the system's moving components.

The R27 rail is subject to the following limitations:

- The maximum number of operators depends on the type of rail, the configuration of installation, and the span length.



IN1643.CLEAR
IN1643

WALL MOUNT

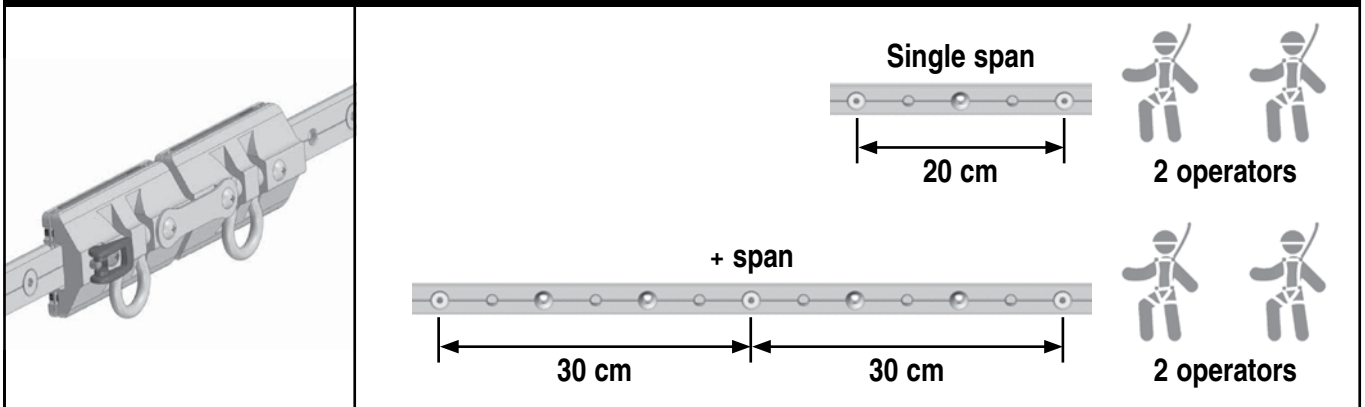

CEILING MOUNT

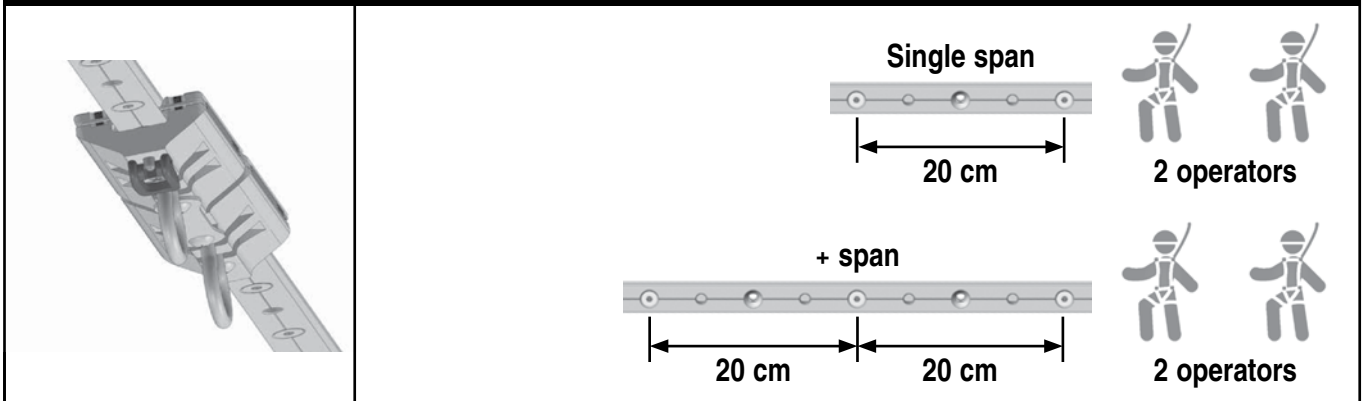

IN1650.CLEAR
IN1650



WALL MOUNT

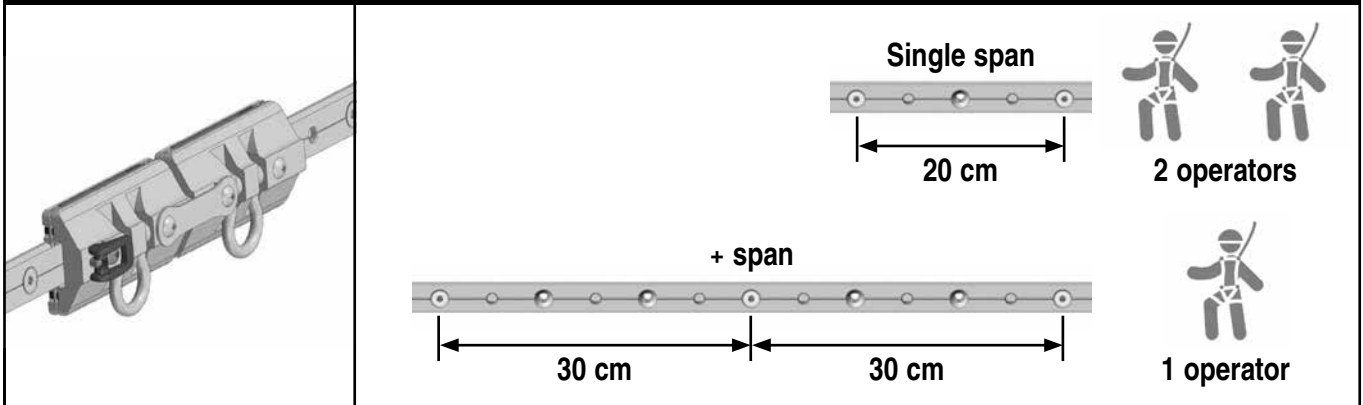

CEILING MOUNT

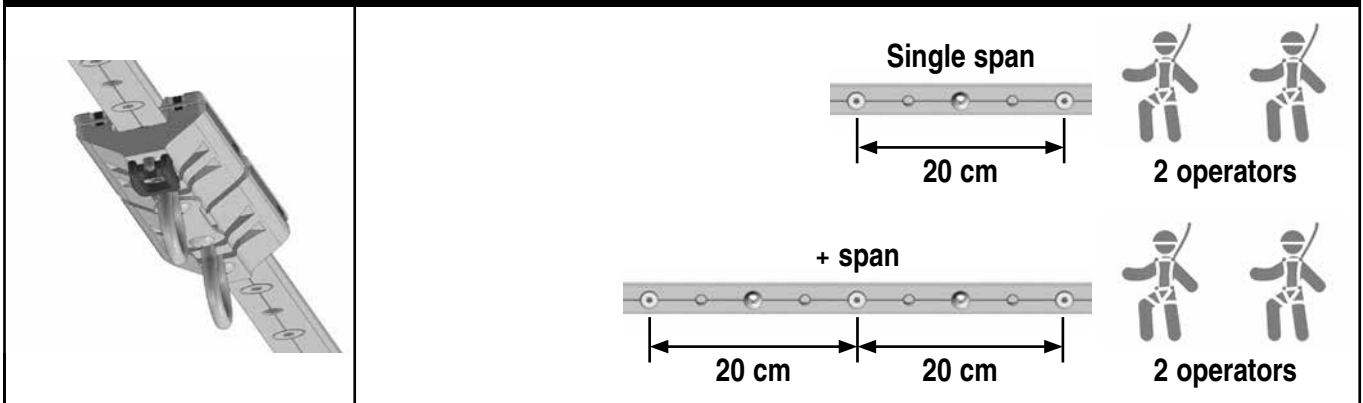

- Do not exceed the maximum number of operators allowed at the same time.
- It must be used only by qualified operators trained on the correct use of the system.
- It can be installed with a maximum inclination of 5° with respect to the horizontal plane.
- It cannot be used outside its limitations or for any purpose other than that for which it is intended.
- It cannot be used as load lifting system.
- It cannot be modified, tampered with, or repaired.
- When using this equipment, the employer must have a rescue plan and the means at hand to implement it. The plan must be communicated to authorized persons and rescuers. The system and trolley integrity **MUST** be assessed prior to any rescue for the safest and quickest recovery.

- **Load angle limitations: IN9606, IN9606.CLEAR, IN9565, IN9565.CLEAR, IN9608, IN9608.CLEAR, IN158, IN158.CLEAR, INCAR1-CURVE, INCAR1-CURVE (BLACK), INCAR2-CURVE, INCAR2-CURVE (BLACK) Trolleys** - Rail must run within 5° of horizontal, but can be mounted at various angles on the vertical mounting structure. Harken IN9606, IN9606.CLEAR, IN9565, IN9565.CLEAR, IN9608, IN9608.CLEAR, IN158, IN158.CLEAR, INCAR1-CURVE, INCAR1-CURVE (BLACK), INCAR2-CURVE, INCAR2-CURVE (BLACK) trolleys have the ability to handle loading at an angle up to 15° beyond vertical. Loads beyond 15° from vertical will overload trolley. See image at right.

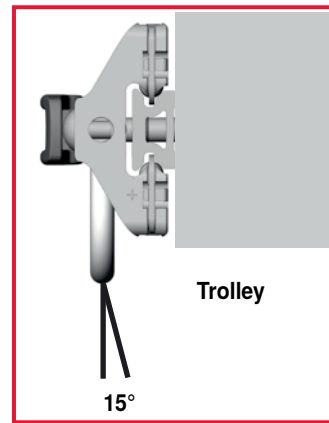

- **Load angle limitations: IN10567, IN10567.CLEAR, IN10614, IN10614.CLEAR, IN10615 and IN10615.CLEAR Trolleys** - Trolleys with wheeled toggles are designed to run along a surface, mounted so that the toggle overhangs the edge. Verify the whole wheel width is in good contact with the surface to which the rail is attached. Verify the surface is strong enough to sustain the expected working load and wear.

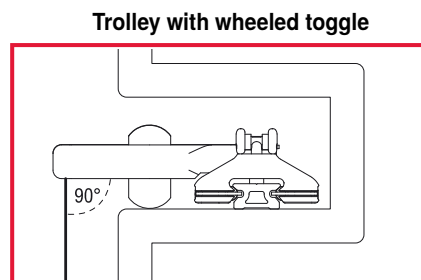

Mounted in recess: trolleys with wheeled toggle for loading over an edge

Mounted on angle: trolleys with wheeled toggle face outward

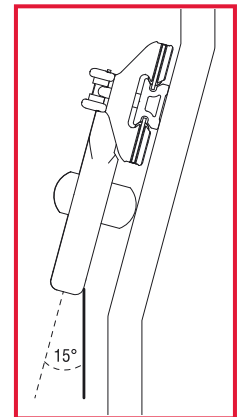

DESIGN

Preliminary information

The fall arrest system must be suitably designed by a qualified professional, since the correct installation and subsequent safety of the users depend on its correct design.

The following are of the utmost importance:

- Analysis of the installation location, in order to define the position where the rail will be installed.
- Definition of anchor points (where the fasteners will be placed).
- Distance between fasteners.
- How to fasten the rail to the supporting structure.

Consider all factors that will affect safety during use of this equipment. Rail must be laid out and positioned strictly in accordance with drawings and specifications supplied by the project authorized architect or other suitably qualified person. System must meet controlling work at height regulations for country of use.

Installer shall ensure suitability of base materials and structural materials to which rail is fixed, follow controlling work at height regulations for country of use, and ensure base and structural materials are capable of sustaining a proof test force.

The capability of the structure to bear the loads connected to a fall arrest system is subject to different assessments, which are excluded from the application of the regulations for which the product is certified.

**NOTE!**

The fastening system must always be designed by a qualified professional.

**NOTE!**

The fall arrest system must be designed, if applicable, for **TOTALLY PREVENTED** or **CONTAINED** falls, so as to prevent significant mechanical stress due a fall in empty space.

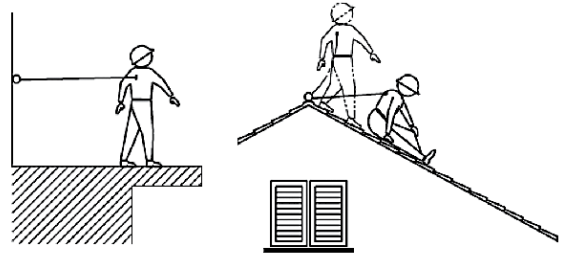
**WARNING!**

In fall arrest systems, it is necessary to verify the absence of sharp edges, which could trail or loop lanyards or lifelines.

The design of the fall arrest system must avoid pendulum falls, which could cause post-fall oscillation of the body with possible impact against obstacles.

**WARNING!**

The structure where the R27 rail will be installed must have structural characteristics so as to support at least the maximum loads of 13 kN in the horizontal and perpendicular direction that could be transmitted in service from the anchor device to the structure. This value has been recorded on the anchor device during the dynamic strength and integrity test and must be taken into account to correctly evaluate the base material, the structural anchorages, or the anchor/fixing point. The system designer must perform the necessary checks to verify the system can be solidly fastened to the structure and that it can withstand the loads in case of fall.

**WARNING!**

It is essential for safety that the anchor device or anchor point should always be positioned, and the work carried out in such a way, as to minimise both the potential for falls and potential fall distance.

Installing the rail

Ceiling, floor, or wall mount

Rail must run within 5° of horizontal, but can be mounted at various angles on the vertical mounting structure. Rail can be ceiling mounted, floor mounted, or wall mounted.

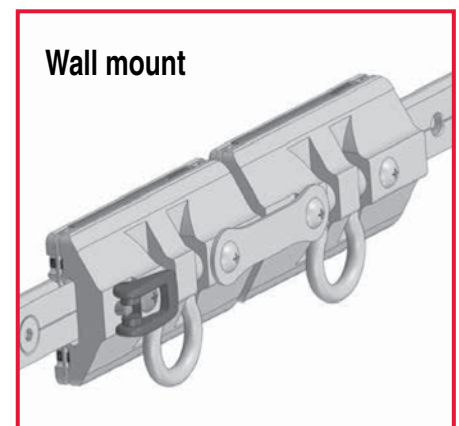
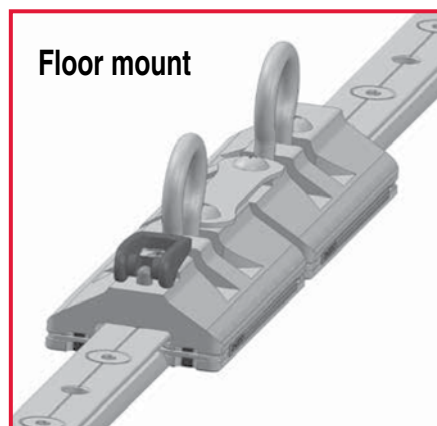
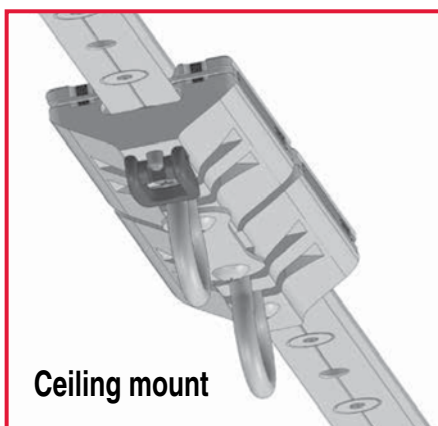

Angled wall mount

An angled wall mount must be limited to a maximum of 15° off vertical. The rail must be mounted so that the load on the shackle is taken no more than 15° beyond vertical. Exception, use trolleys with wheeled toggles for greater angles.

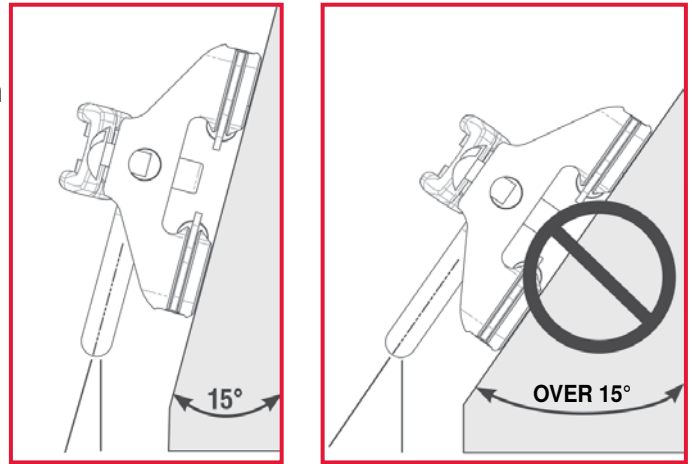

NOTE!

For optimum trolley performance on the rail, we recommend installing the rail so the load is perpendicular to the sliding plane of the trolley on the rail.



↑
Sliding plane

Colored rail

The standard rail is supplied in (CLEAR) anodized aluminium color. Aluminium rail can be supplied with powder coating or anodizing colored upon request. For more information, contact Harken.

Bent rail

The rail can be installed on bent surfaces, which have a minimum bending radius of 15 m. The rail can be bent manually in any of the three directions shown below during installation.



For bending radius between 2.75 m and 15 m in any of the three directions shown above, contact Harken to request the rail be bent to the specified radius. The bent rail has 25 cm of straight rail at the extremity due to the production process. For more information contact Harken.

INSTALLATION

Thermal expansion

Since the rail is made of an aluminium alloy Series 6000 (thermal expansion coefficient: $23 \times 10^{-6} \text{m}/^\circ\text{C}$), during the design phase, it is necessary to evaluate the rail thermal expansion based on the length of the rail which may occur when the temperature varies. It is the responsibility of the system designer (qualified engineer) to carefully evaluate the thermal expansion which will be submitted to the system. The system designer must analyze the relative coefficient of thermal expansion of rail and mounting material and decide on the appropriate method of mounting and sealing fasteners and gaps between rail sections.

As a general rule, leave a space between the end of one rail segment and the next to allow for thermal expansion.

Spacing of 3 mm (.118") is appropriate and will allow the trolley assembly to roll smoothly over the gap. Use the O-ring supplied with the IN1649 and IN1651. Splice links using a spacer tool to set the gap between the rails. Follow mounting instructions for alignment and fasteners at splice links. Joints must be supported on either side by a fastener 50 mm from rail end.

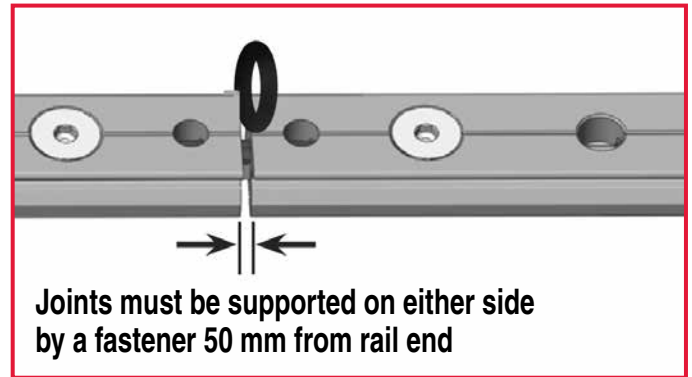

The R27 rail operating temperature range is -50°C to $+80^\circ\text{C}$. For out-of-range applications, contact Harken or Harken dealer.

INSTALLATION

The R27 rail must be installed by Harken dealer's authorized installers or by qualified professionals, trained to design, install, certify, and service the fall arrest system. For a list of Harken's authorized installers, go to www.harken.com.

To evaluate the base material, the structural anchorages, or the anchor/fixing correctly, take into account the loads registered on the anchoring device during the dynamic and integrity tests indicated in the Design section.

The installer carries the full responsibility for a proper and safe installation that is tested to meet all relevant standards. Normally this would be verified by an independent safety engineer/surveyor.

Correct installation must be verified by a supervisor or a safety officer through calculations or tests. After completing the installation, the installer must issue the related documents required by reference regulations and must fix and display the documents near the system access point the sign indicating:

- Name and contact information of the manufacturer
- Name and contact information of the installing company
- System serial number
- Type of fixing devices
- Installation date
- Maximum number of operators that can connect at the same time
- Obligation to use the PPE
- Notice to refer to the contents of the anchoring system booklet
- Date of the inspection or the date of the last inspection along with the inspection schedule
- Notice to avoid using the anchoring system if the inspection has not been performed

After the installation, a copy of the installation documents must be submitted to the client. These documents must be kept in the building for following inspections of the anchoring device.

Rail installation guidelines

The fastening of the rail must be performed by the installer in the manner defined by the designer (engineer enabled) who is responsible for the design of the system and the related certification. It is not possible to define a standard number and type of fasteners, as this is dependent on the material into which the rail is installed, the intended purpose, and the subsequent maximum load requirement of that purpose.

Rail and fastener specifications

IN1643 and IN1643.CLEAR rail uses M8 (5/16") countersunk fasteners. IN1650 and IN1650.CLEAR rail uses M8 (5/16") socket head fasteners.

Fastener material

All rails listed in this manual are designed to use stainless steel fasteners. Harken does not recommend using aluminum fasteners for installation. The installer is responsible for the use of non-stainless steel fasteners and could be held liable. Fasteners must be designed to meet the requirements of controlling work at height regulations for country of use.



WARNING!

An incorrectly fastened system may not guarantee the adequate resistance to a fall, and could result in fatal injuries.

The R27 rail can be installed with a maximum inclination of 5° with respect to the horizontal plane.

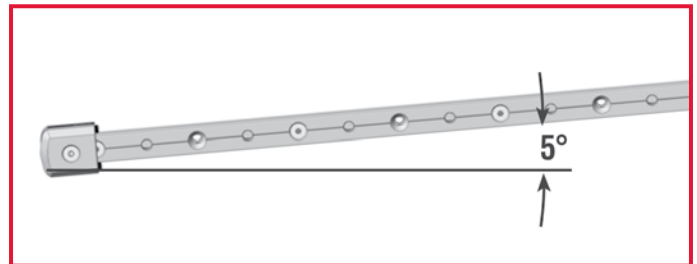

Joining rail segments

Precise rail alignment at joints is critical for smooth-running trolleys. Fasten each rail segment in the last fastener hole near the splice link. Use the IN1649 for IN1643 and IN1643.CLEAR rail with countersunk fastener or IN1651 for IN1650 and IN1650.CLEAR rail with socket head fastener. Use spring clamps to align rails during installation. The splice link is not structural and is used only to maintain alignment and linearity of the individual rail segments. See thermal expansion section for using O-ring as spacer tool.

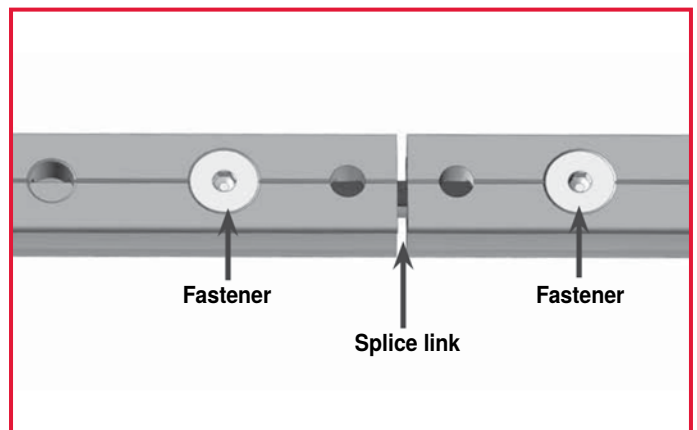

Drilling holes

Use transfer punch to mark hole centers. Hold rail in alignment until secured with spring or "C" clamps when marking and drilling holes. The first fastener must be 50 mm to rail end or less.

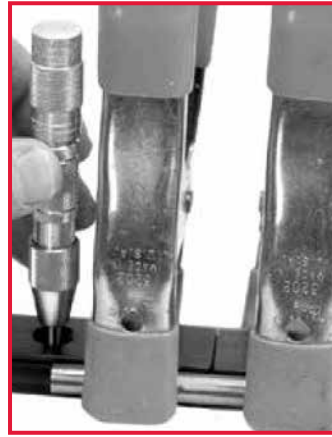

Threadlocking fasteners

Always use threadlocking solution or locknuts.

Preventing corrosion between fasteners and rail

Use an anticorrosion paste on the fastener head to prevent galvanic corrosion between fastener and rail. Do not use for nuts on fastener.

The R27 rail must be connected to the lightning protection system in compliance with current regulations.

Endstop assembly instructions

Using IN1642.CLEAR removable endstops

Endstops allow the user to easily remove trolley assemblies for storage away from the elements and for switching trolley assemblies from one rail to another. Use the end pin to remove and insert the end fitting.

NOTE: Verify the first rail mounting fastener is located within 50 mm of the rail end.

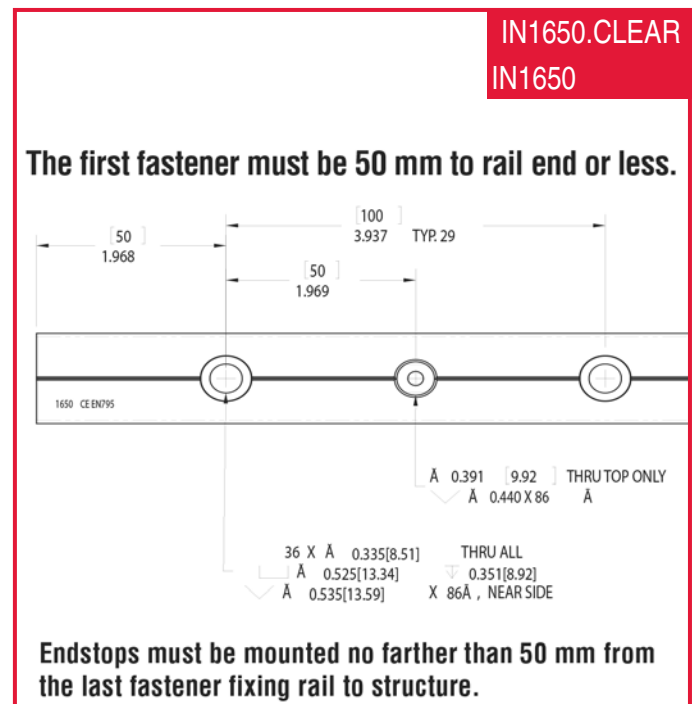
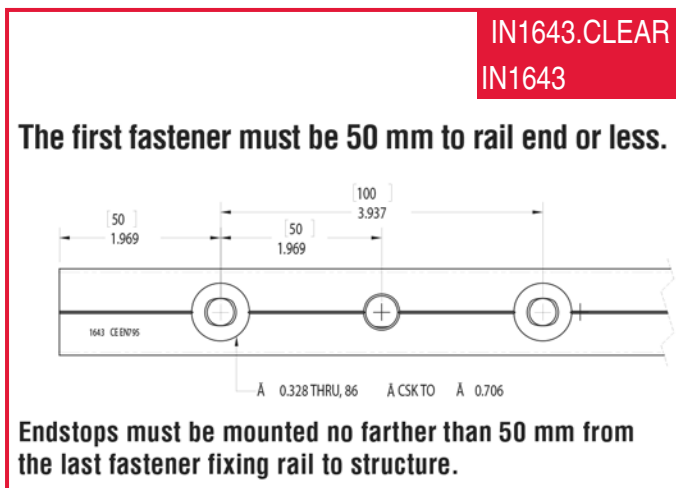

Drill a \varnothing 10 mm hole in the rail centerline through the top surface only for the removable endstop.
Endstops must be mounted no farther than 50 mm from the last fastener fixing rail to structure.

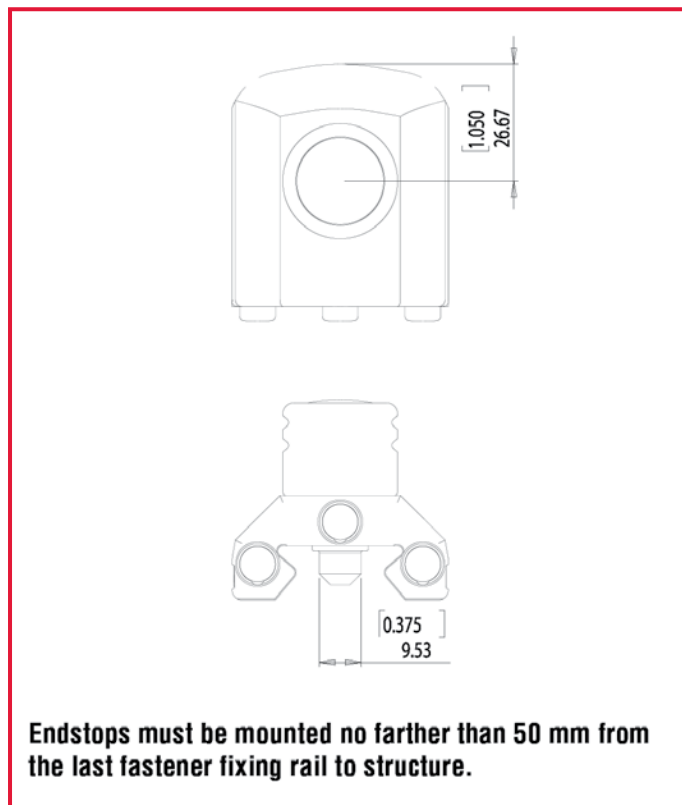

WARNING!

Verify the pinstop is securely fastened to a pinstop hole in the rail. The bottom of the knob must be nearly flush with the body of the endstop. Failure to seat in a pinstop hole can result in a fall which could result in severe injury or death.

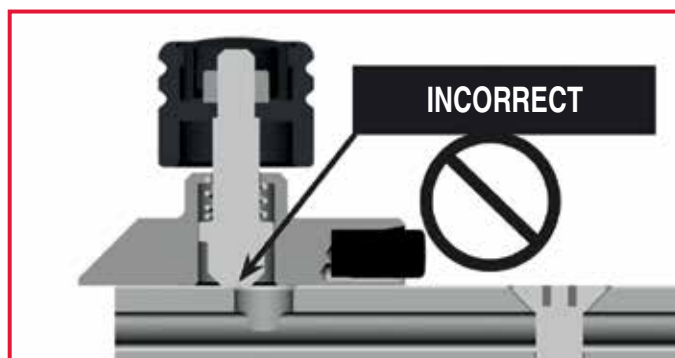
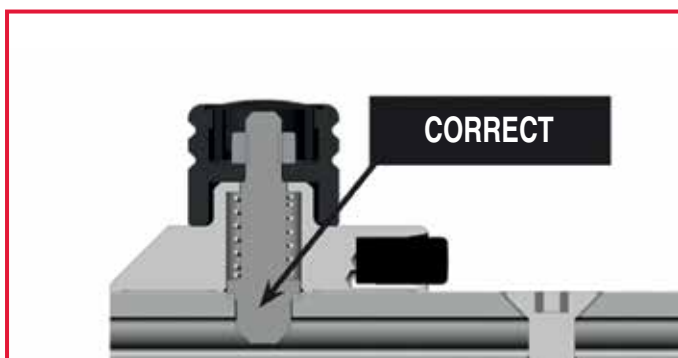

WARNING!

Removable endstops MUST be tethered to the system or a suitable anchor point to prevent falling objects.

PRELIMINARY AND PERIODIC CHECKS

Installing IN9561.CLEAR endstops

Fasten endstops to rail ends using flathead M8 (5/16") stainless steel fasteners. Drill a M8 threaded hole in the rail centerline and tap into the rail to mount endstop. Note hole center locations below and plan endstop location on rail to avoid interference from the predrilled mounting or pinstop holes. Endstops must be mounted no farther than 50 mm from the last fastener fixing rail to structure. Use an anticorrosion paste on the endstop fastener head to prevent galvanic corrosion between fastener and rail.

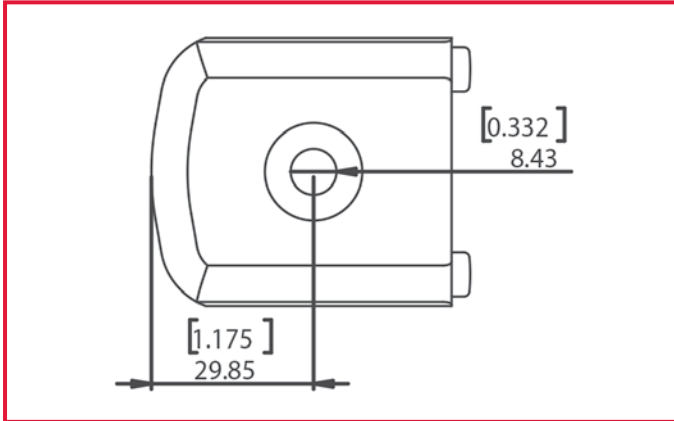

PRELIMINARY AND PERIODIC CHECKS

Before using the R27 rail, visually check its condition and each component:

- Check rail for dirt buildup. If the rail has visible dirt or feels gritty, clean the rail ahead of trolley as part of maintenance.
- Verify the system components are not deformed, the screws are not loose, and there are no signs of wear, corrosion, or buildup of dirt. If any faults or damaged parts are identified, do not use the system.
- Check the most critical components: connectors, fasteners, and (mobile/fixed) end fittings.



WARNING!

If all screws are not fastened securely, rail can separate from mounting surface resulting in a fall, severe injury, or death.

- Verify screws have not loosened and are flush with top of rail so trolleys roll smoothly. Loose screws can also compromise system safety. Inspect the rail by running the trolley assembly the entire length without load. Verify the trolley assembly runs freely and hits no screw heads or obstructions.



- Verify endstop screws of the IN9561 endstop have not loosened. Screws must be flush with the top of the endstop.



- Verify pinstop of the IN1642.CLEAR endstop is securely fastened to a pinstop hole in the rail. The bottom of the knob must be nearly flush with the body of the endstop.

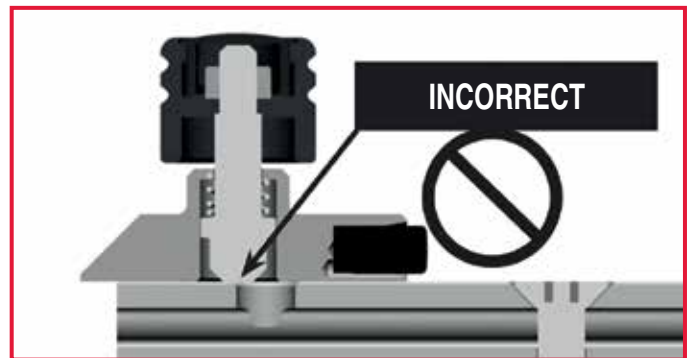
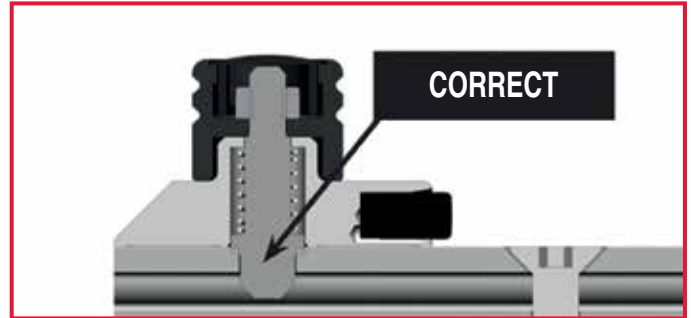

WARNING!

If endstop screws loosen or fail to seat in a pinstop hole, trolleys can roll off end of rail resulting in a fall, which could cause severe injury or death.

- Visually verify the supporting structure (where the fall arrest system is installed) does not show signs of deterioration.
- In case of faults or damaged parts contact the safety officer, who will call Harken or Harken dealer's authorized personnel or qualified personnel to inspect the system.
- In case of a fall, request an inspection of the fall arrest system from Harken, Harken dealer's authorized personnel, or qualified personnel.



WARNING!

If rail has been subjected to the forces of arresting a fall or there is any doubt about its condition for safe use, immediately remove from service until confirmed in writing by a Harken dealer's authorized personnel or qualified personnel to inspect the system that it is acceptable to use.

- In case of lightning, fires, or intense weather events, do not use the fall arrest system and call Harken, Harken dealer's authorized personnel, or qualified personnel to inspect it.
- Check the legibility of the rail markings.

PACKAGING - STORAGE - TRANSPORTATION

Annual check

The rail must be thoroughly inspected at least once every 12 months for fall arrest specification, or six months for human suspension, if regularly used, or before using it after a long period of inactivity. Based on the frequency of use and on the place of installation of the rail, the maintenance schedule may vary.



WARNING!

Regular inspections are required for the safety of users because the safety of users depends upon the continued efficiency and durability of the equipment.

Do not use the fall arrest system without performing the compulsory servicing. The inspection performed by Harken, Harken dealer's authorized personnel, or qualified personnel must be recorded in the Maintenance Record of this manual.

The system must be branded with the date of the next inspection or the date the inspection was performed.



WARNING!

DO NOT USE the R27 rail if:

- you detect damage, wear, corrosion, or deformation on the rail or related components (such as endstops, anchor/fixing, and attaching fasteners)
- faults are detected during the compulsory periodical inspection
- a fall with consequent stress for the rail has occurred

PACKAGING, STORAGE, TRANSPORTATION

Every rail is supplied by Harken in its original packaging to prevent dust, dirt, and potential damages.

Check the packaging integrity and if damaged, proceed with an inspection before installing the rails.

Store in original packaging during storage and transportation.

Store the rails in a dry, ventilated, low humidity, salt free environment to avoid corrosion and protect against impacts, chemical reagents, or other damage, which may affect the performance of the rail.

MAINTENANCE

To keep the rail in proper working conditions, remove any dirt, grease, snow, ice, or anything that could prevent the trolley from sliding correctly on the rail. In particular, clean the rail section in contact with the trolley's ball bearings. Only use non-abrasive cleaning tools and mild liquid soaps. Use soapy water and flush thoroughly with clean water.

Do not let the rail come into contact with concrete, asphalt, paints, acids, solvents, or chemical reagents. For the trolley maintenance, refer to the proper manual.

CERTIFICATIONS

The R27 rail (IN1643, IN1643.CLEAR, IN1650, IN1650.CLEAR), and related components are compliant to the test set out by Standards EN795:2012 Type D and CEN/TS16415:2013. Furthermore, the R27 rail (IN1643, IN1643.CLEAR, IN1650, IN1650.CLEAR) and related components are certified according to the Standard UNI11578:2015.

LABELING

The rail will be marked in one of the following ways:

IN1643.CLEAR
IN1643

Manufacturer Trademark → **HARKEN**

Serial number ← **YYYYDDD-XXXX**

Read the manual → **EN 795/12-CEN/TS 16415/13**

Read the manual → **MAX** **UNI 11578/15**

Rail Model identification → **R27**

Rail Model ← **IN 1643**

Month and Year of Manufacture ← **mm-yy**

European Standard ← **EN 795/12-CEN/TS 16415/13**

European Standard ← **UNI 11578/15**

Operators max number ↑ **MAX**

IN1650.CLEAR
IN1650

Manufacturer Trademark → **HARKEN**

Serial number ← **YYYYDDD-XXXX**

Read the manual → **EN 795/12-CEN/TS 16415/13**

Read the manual → **MAX** **UNI 11578/15**

Rail Model identification → **R27**

Rail Model ← **IN 1650**

Month and Year of Manufacture ← **mm-yy**

European Standard ← **EN 795/12-CEN/TS 16415/13**

European Standard ← **UNI 11578/15**

Operators max number ↑ **MAX**

WARRANTY

For the warranty, refer to Harken Global Limited Warranty on the website: <http://www.harken.com>.

DOLOMITICERT

Italian Institute for the Certification of Personal Protective Equipment
S.C.A.R.L.

Address: Villanova Zona Industriale, 7/A
32013 LONGARONE (BL) - ITALY
Tel.: +39 0437 573407 Fax: +39 0437 573131
Web site: www.dolomiticert.it E-mail: info@dolomiticert.it



ATTESTATION OF CONFORMITY number 192061

Verifications for anchor devices according to the Standards EN 795:2012 “Personal fall protection equipment – Anchor devices”, CEN/TS 16415:2013 “Personal fall protection equipment – Anchor devices – Recommendations for anchor devices for use by more than one person simultaneously” and UNI 11578:2015 “Anchor devices intended for permanent installation”

Anchor device
Model:
ACCESS RAIL SYSTEM – R27

Date: *16th of December 2019*

Responsible for the evaluation
Luca Tamburlin



Applicant:
HARKEN Inc., USA
One Harken Way-N15W24983 Bluemound Road - 53072 PEWAUKEE WISCONSIN - USA

Note 1: The Attestation of Conformity loses its validity if any modifications are made as compared with the original and tested product.

Note 2: Dolomiticert only allows partial disclosure of the present Attestation of Conformity upon written authorization.

Note 3: This Attestation of Conformity issued by Dolomiticert under a voluntary basis.

CORRECT INSTALLATION FORM

With reference to the installation of the fall arrest system installed on

System serial number: _____ Project: _____

Description of the building: _____

Address: _____

City: _____ Country: _____ Post code: _____

The INSTALLER

First name: _____ Last name: _____

Legal representative of the company: _____

With headquarters at: _____ City: _____

VAT number: _____

DECLARES
that the following systems and fastening devices used

Manufacturer	Product	Model	Type	Tensile forces allowed

HAVE BEEN INSTALLED CORRECTLY

- In compliance with the manufacturer's installation instructions, they have been installed in compliance with the project drafted by the Arch./Eng./Surv.: _____
- They have been fastened to the specified structure, in compliance with the instructions supplied in the calculation report drafted by the Arch./Eng./Surv.: _____
- They have been fixed as specified (e.g. numbers of bolts, correct materials, correct position/location).
- They have been commissioned in accordance with the manufacturer's information.
- They have been supplied with photographic information/documentation, especially where fixing (e.g. bolts) and the underlying substrate are no longer visible after completing the installation.
- The fastening/anchoring element structural characteristics, their use instructions, the manuals of the different products used, the installation layout, and the documents/pictures taken and drafted during the installation have been submitted to:

First name: _____ Last name: _____

Role: _____

The compulsory SIGN
has been affixed near every access and/or onto the fall arrest system

System installation date

The installer (Stamp and Signature)

ACCEPTANCE REPORT

The undersigned:

As client of the fall arrest system to which this manual is referred, installed on:

System serial number:

Project:

Description of the building:

Address:

City:

Province:

Zip code:

DECLARES

To have received from the installing company:

- the installation documents, including the relevant annexes
- the use and maintenance manual for the system components
- the fastening/anchoring device documents
- the installation layout related to the system
- the documents/pictures taken and drafted during the installation

and to make them available to the user.

Place and date

The Client

(Stamp and Signature)

EXAMPLE OF LICENSE PLATE



Type:

Model:

> Read carefully the Instruction manual
> Personal Protection Equipment **REQUIRED**

Compliant:

Certified:

Installation Date

N° max of users:



MANUFACTURER



Harken Inc., USA
One Harken Way – N15W24983 Bluemound Road
Pewaukee, Wisconsin 53072 USA
T: (262) 691-3320 F: (262) 701-5780
E: harken@harken.com www.harken.com

DISTRIBUTOR



Harken Italy S.p.A.
Via Marco Biagi, 14
22070 Limido Comasco (CO) - Italia
T: (39) 031-3523511 F: (39) 031-3520031
E: industrial@harken.it www.harkenindustrial.com

INSTALLER

Periodic inspection (fill in the forms in the Instruction Manual)

Next Inspection Date	Next Inspection Date	Next Inspection Date	Next Inspection Date

Notes:

- 1) The installation of Anchoring System must be run by personnel trained and authorized by Harken or by Harken Partners.
- 2) Before accessing and using the Anchoring System it is necessary to read carefully the Instruction Manual and all the Anchoring System related documents.
- 3) Before using the Anchor System, it is essential for safety to verify the fall clearance required beneath the user at the work place and to choose the appropriate PPE.
- 4) Before using the Anchor System verify its integrity and carry out a visual inspection of each component. If you find damaged parts or you have any doubt, DO NOT use the system and contact the competent and authorized personnel in charge to carry out the rail inspection.
- 5) Use the Anchor System with Personal Protective Equipment 3rd category according to regulations in the field of security and all PPE as required by the legislation.
- 6) Harken is not responsible for any injury or damage caused by improper use of the Anchor System.
- 7) Mandatory testing of the Anchor System by Harken authorized personnel is required after a fall.
- 8) The periodic inspection must be carried out as prescribed by the EN11158: 2005 and at least once every 12 months from the date of installation indicated above, if used regularly, otherwise before using after a long period of inactivity. The system must not be used if the inspection has not taken place.
- 9) Periodic inspections should be performed by experienced people, who are aware of the recommendations and instructions issued by the manufacturer applied to the components of the system, and which are licensed by Harken.

MAINTENANCE-INSPECTION REGISTER

RECORD

PRODUCT	PURCHASE DATE	DATE FIRST PUT INTO USE
MODEL AND TYPE	TRADE NAME	IDENTIFICATION NUMBER

MANUFACTURER: _____

ADDRESS: _____

TEL: _____ FAX: _____ E-MAIL: _____

WEBSITE: _____

COMPANY CARRYING OUT THE MAINTENANCE OPERATIONS

PERSON IN CHARGE (First name and Last name)		DESCRIPTION OF THE INTERVENTION	OUTCOME
Date	Signature	<input type="checkbox"/> Periodic inspection <input type="checkbox"/> Repair	<input type="checkbox"/> Positive <input type="checkbox"/> Negative

Scheduled date for the next periodic inspection: _____

NOTES

COMPANY CARRYING OUT THE MAINTENANCE OPERATIONS

PERSON IN CHARGE (First name and Last name)		DESCRIPTION OF THE INTERVENTION	OUTCOME
Date	Signature	<input type="checkbox"/> Periodic inspection <input type="checkbox"/> Repair	<input type="checkbox"/> Positive <input type="checkbox"/> Negative

Scheduled date for the next periodic inspection: _____

NOTES

MAINTENANCE-INSPECTION REGISTER

COMPANY CARRYING OUT THE MAINTENANCE OPERATIONS

PERSON IN CHARGE (First name and Last name)

DESCRIPTION OF THE INTERVENTION

OUTCOME

Periodic inspection

Positive

Repair

Negative

Date

Signature

Scheduled date for the next periodic inspection:

NOTES

COMPANY CARRYING OUT THE MAINTENANCE OPERATIONS

PERSON IN CHARGE (First name and Last name)

DESCRIPTION OF THE INTERVENTION

OUTCOME

Periodic inspection

Positive

Repair

Negative

Date

Signature

Scheduled date for the next periodic inspection:

NOTES

COMPANY CARRYING OUT THE MAINTENANCE OPERATIONS

PERSON IN CHARGE (First name and Last name)

DESCRIPTION OF THE INTERVENTION

OUTCOME

Periodic inspection

Positive

Repair

Negative

Date

Signature

Scheduled date for the next periodic inspection:

NOTES

HARKEN®

Manufacturer

Harken Inc. USA

One Harken Way
N15W24983 Bluemound Road,
Pewaukee, Wisconsin 53072 USA
Telephone: (262) 691-3320 • Fax: (262) 701-5780
Web: www.harken.com • www.harken.com
Email: harken@harken.com

EU Representative

Harken Italy S.p.A.
Via Marco Biagi 14, 22070 Limido Comasco (CO), Italy
Tel +39.031.3523511 • Fax +39.031.3520031
Web: www.harken.it
Email: info@harken.it